



Sortimentsliste/*Product Range* 2013



Hermann Wendler

Strongbelt

Antriebstechnik

Metall
Metal

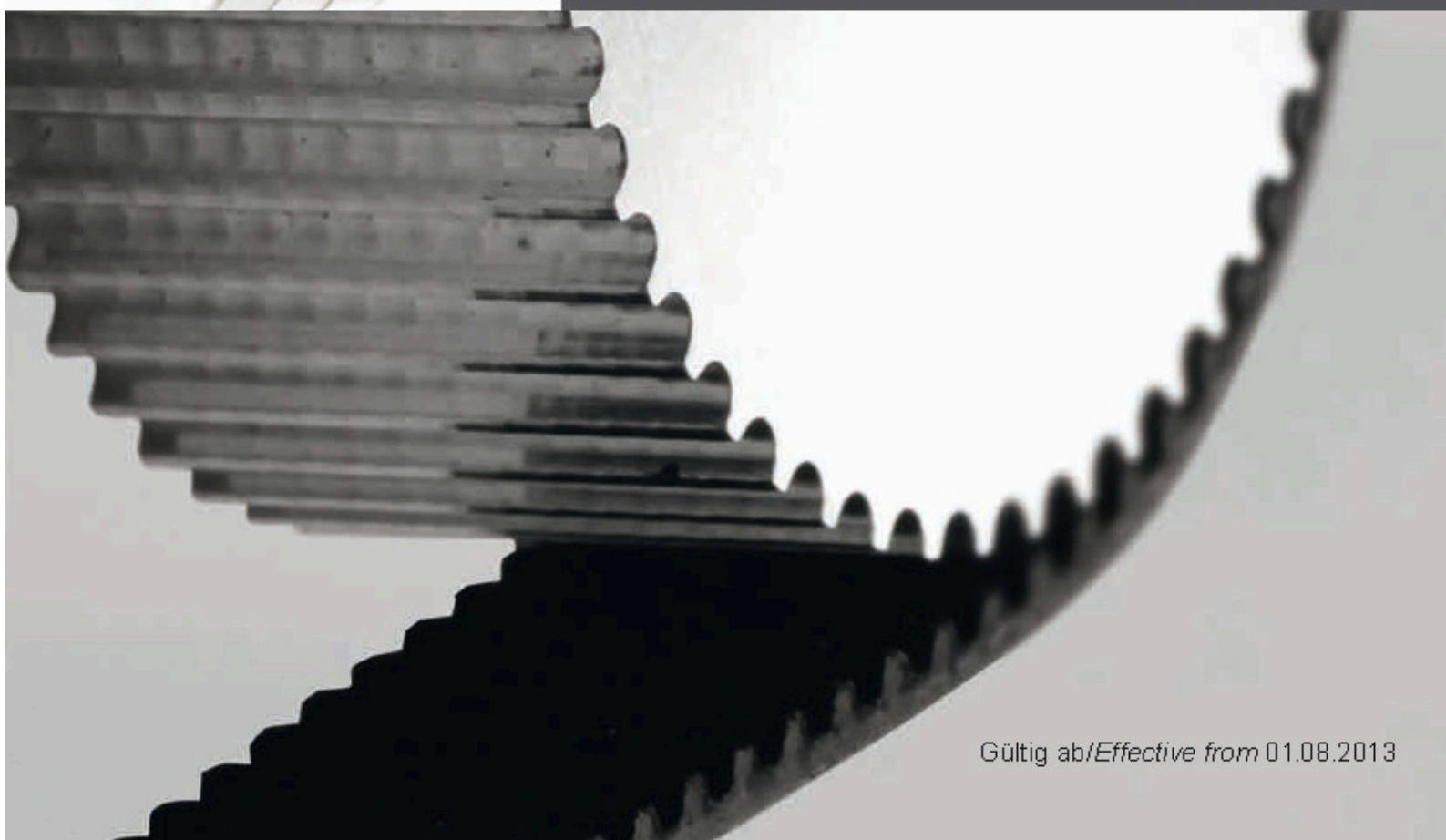

Gültig ab/*Effective from* 01.08.2013

Inhaltsverzeichnis

Contents

Seite
Page

Taperbuchsen <i>Taper bushes</i>	3-4
Ausführungen der Keilrillenscheiben – Auswuchten, Aufschläge für Fertigbohrungen <i>V-grooved pulleys, types – balancing, surcharges for finished bores</i>	5
Keilrillenscheiben für Taperbuchsen – Rillen nach DIN 2211 <i>V-grooved pulleys for taper bushes – grooves to ISO/BS/DIN</i>	6-14
Keilrillenscheiben für zylindrische Bohrung – Rillen nach DIN 2211 <i>V-grooved pulleys for plain boring – grooves to ISO/BS/DIN</i>	15-20
Regelscheiben <i>Variable speed pulleys</i>	21-23
Keilrippenscheiben für Taperbuchsen <i>Ribbed belt pulleys for taper bushes</i>	24-28
Keilrippenscheiben für zylindrische Bohrung <i>Ribbed belt pulleys for plain boring</i>	28
Flachriemenscheiben für Taperbuchsen <i>Flat belt pulleys for taper bushes</i>	29
Motorspannschienen <i>Motor slide rails</i>	30
Motorspannschlitten <i>Motor slide bases</i>	31
Standard-Zahnscheiben für zylindrische Bohrung und Taperbuchsen <i>Timing belt pulleys for plain boring and taper bushes</i>	32-43
HTD®-Zahnscheiben für zylindrische Bohrung und Taperbuchsen <i>HTD® pulleys for plain boring and taper bushes</i>	44-57
Metrische Zahnscheiben für zylindrische Bohrung, T- und AT-Type <i>Metric timing belt pulleys for plain boring, T sections</i>	58-66
Standard-Zahnwellen <i>Timing bars – standard timing belts</i>	67-68
Metrische Zahnwellen <i>Timing bars – metric timing belts</i>	69-70
Kettenräder <i>Sprockets</i>	71-79
Kettenradscheiben <i>Plate wheels</i>	80-88
Kettenräder für Taperbuchsen <i>Taper bored sprockets</i>	89-94
Taperbuchsen <i>Taper bushes</i>	95
Führungsschienen, Kettenführungen und Riemenführungen <i>Guide rails, chain guides and belt guides</i>	96
Tapernaben <i>Taper hubs</i>	97
Zwischenhülsen <i>Adapters</i>	98
Spannelemente <i>Clamping bushes</i>	99-114
Klemmplatten für Zahnriemen und Polyurethan-Zahnriemen <i>Clamping plates for Timing Belts and Polyurethane-Timing Belts</i>	115-116

Taperbuchsen

Taper bushes

Taperbuchsen mit Zoll-Bohrung, Nut nach Britischem Standard BS 46 Teil 1
Taper bushes with inch bores. Keyways to BS 46 Part 1

	Taperbuchse Taper bush															Material: EN-GJL 200 – DIN EN 1561				
	1008	1108	1210	1215	1310	1610	1615	2012	2517	3020	3030	3525	3535	4040	4545	5050				
Bohrungs- durch- messer Bore diameter d ₂ (Zoll inch)	3/8	3/8	1/2	5/8	1/2	1/2	1/2	5/8	3/4	1 1/4	1 1/4	1 1/2	1 1/2	1 3/4	2 1/4	3				
	1/2	1/2	5/8	3/4	5/8	5/8	5/8	3/4	7/8	1 3/8	1 3/8	1 5/8	1 5/8	1 7/8	2 3/8	3 1/4				
	5/8	5/8	3/4	7/8	3/4	3/4	3/4	7/8	1	1 1/2	1 1/2	1 3/4	1 3/4	2	2 1/2	3 1/2				
	3/4	3/4	7/8	1	7/8	7/8	7/8	1	1 1/8	1 5/8	1 5/8	1 7/8	1 7/8	2 1/8	2 3/4	3 3/4				
	7/8	7/8	1	1 1/8	1	1	1	1 1/8	1 1/4	1 3/4	1 3/4	2	2	2 1/4	2 7/8	4				
	1▲	1	1 1/8	1 1/4	1 1/8	1 1/8	1 1/8	1 1/4	1 3/8	1 7/8	1 7/8	2 1/8	2 1/8	2 3/8	3	4 1/4				
		1 1/8▲	1 1/4		1 1/4	1 1/4	1 1/4	1 3/8	1 1/2	2	2	2 1/4	2 1/4	2 1/2	3 1/4	4 1/2				
					1 3/8	1 3/8	1 3/8	1 1/2	1 5/8	2 1/8	2 1/8	2 3/8	2 3/8	2 5/8	3 3/8	4 3/4				
					1 1/2	1 1/2	1 5/8	1 3/4	2 1/4	2 1/4	2 1/2	2 1/2	2 3/4	2 3/4	3 1/2	5▲				
					1 5/8	1 5/8▲	1 3/4	1 7/8	2 3/8	2 3/8	2 5/8	2 5/8	2 5/8	2 7/8	3 3/4					
								1 7/8	2	2 1/2	2 1/2	2 3/4	2 3/4	3	4					
								2	2 1/8	2 5/8	2 5/8	2 7/8	2 7/8	3 1/8	3 1/8	4 1/4▲				
									2 1/4	2 3/4	2 3/4	3	3	3 1/4	3 1/4	4 1/2▲				
									2 3/8	2 7/8	2 7/8	3 1/8	3 1/8	3 3/8						
									2 1/2	3	3	3 1/4	3 1/4	3 1/2						
											3 3/8	3 3/8	3 3/4▲							
											3 1/2▲	3 1/2▲	4▲							
Innensechskantschrauben Hexagon socket screws (Zoll inch)	1/4 x 1/2	1/4 x 1/2	3/8 x 5/8	3/8 x 5/8	3/8 x 5/8	3/8 x 5/8	3/8 x 5/8	7/16 x 7/8	1/2 x 1	5/8 x 1 1/4	5/8 x 1 1/4	1/2 x 1 1/2	1/2 x 1 1/2	5/8 x 1 3/4	3/4 x 2	7/8 x 2 1/4				
Anzug Tightening torque (Nm)	5,7	5,7	20	20	20	20	20	31	49	92	92	115	115	172	195	275				
Buchsenlänge Bush length (mm)	22,3	22,3	25,4	38,1	25,4	25,4	38,1	31,8	44,5	50,8	76,2	63,5	88,9	101,6	114,3	127,0				
Gewicht bei Weight at d ₂ min (≈ kg)	0,12	0,16	0,28	0,39	0,32	0,41	0,60	0,75	1,06	2,50	3,75	3,90	5,13	7,68	12,70	15,17				
€ Stück each	auf Anfrage on request																			

Flachnute für Taperbuchsen Shallow keyways for taper bushes

Bohrungsdurchmesser Bore diameter d ₂ (mm)	Nutbreite Keyway width b (mm)	Nuttiefe Keyway depth t ₂ (mm)	Bohrungsdurchmesser Bore diameter d ₂ (mm)	Nutbreite Keyway width b (mm)	Nuttiefe Keyway depth t ₂ (mm)
24	8	2,0	28	8	2,0
25	8	1,3	42	12	2,2

Ab 3525: Zylinderkopfschraube mit Innensechskant From 3525: Hexagon head screw

▲ Diese Bohrung ist mit Flachnut ausgeführt. These bores have shallow keyways.

Ausführungen der Keilrillenscheiben – Auswuchten, Aufschläge für Fertigbohrungen V-grooved pulleys, types – balancing, surcharges for finished bores

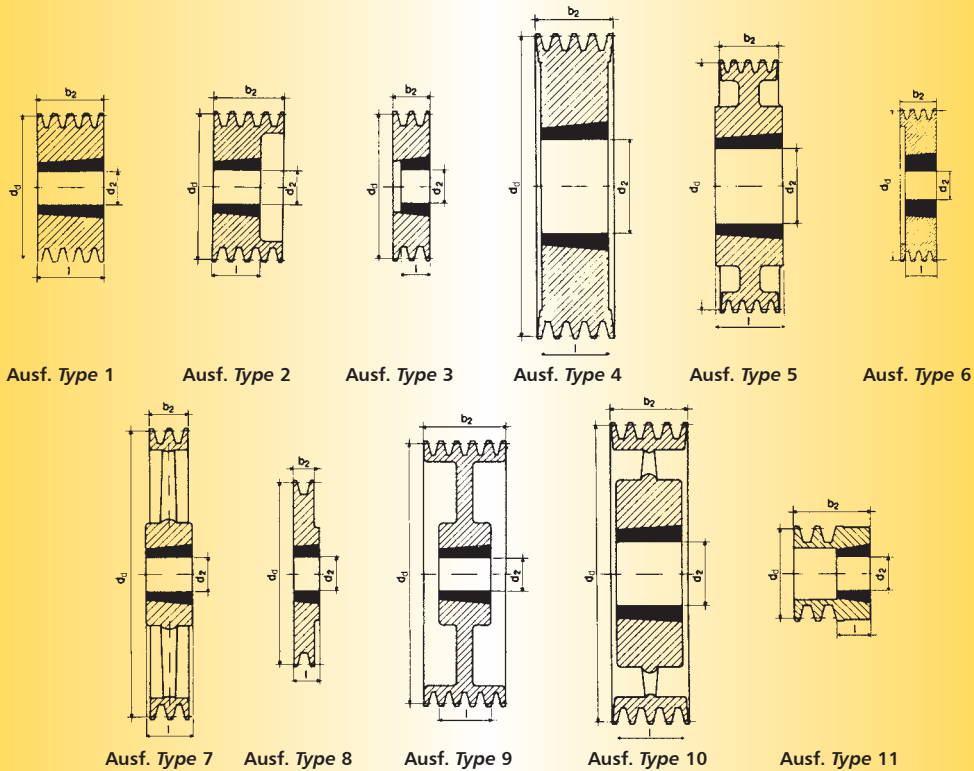

Fertigungstechnische Änderungen der Ausführungen vorbehalten.
We reserve the right to make technical changes.

Auswuchten

Die Listenpreise gelten für in einer Ebene nach DIN/ISO 1940 ausgewuchtete GG-Scheiben wie folgt:
Gütestufe G 6,3 für $\varnothing d_d \leq 400$ mm bei $n = 1500$ min⁻¹, für $\varnothing d_d > 400$ mm bei $v = 30$ m/s.

Die Auswuchtung wird ohne Nut auf glattem Wuchtdorn vorgenommen. Für Maschinen, deren Läufer mit einer in das Wellenende eingesetzten vollen Passfeder ausgewuchtet sind, muss mit folgendem Vermerk bestellt werden: »Ausgewuchtet mit Fertigbohrung und leerer Nut auf glattem Wuchtdorn ohne eingesetzte Passfeder«.

Ein Auswuchten in zwei Ebenen Gütestufe G 6,3 oder feiner ist erforderlich, wenn $v \geq 30$ m/s oder das Verhältnis Richtdurchmesser zu Kranzbreite $d_d : b_2 < 4$ ist bei $v > 20$ m/s.

Mehrpreis auf Anfrage nach Bekanntgabe der Betriebsdrehzahl.

Balancing

The list prices apply, as per VDI 2060, to cast iron pulleys balanced in one plane as follows:

Grade G 6.3 for $d_d \leq 400$ mm at $n = 1500$ rpm, for $d_d > 400$ mm at $v = 30$ m/sec.

Balancing is carried out minus the key on a smooth mandrel. Machines where the rotors are balanced with an adjusting spring inserted in the shaft end must be ordered as follows: "Balanced with finished bore without key on a smooth mandrel without inserted spring".

We recommend balancing in two planes grade G 6.3 or better if $v \geq 30$ m/sec. or if the ratio between datum diameter and pulley face width $d_d : b_2 < 4$ at $v > 20$ m/sec.

Surcharges for balancing on request. Please give pulley operating speed.

Aufschläge für Fertigbohrung H7 und Passfedernut nach DIN 6885 Teil 1 Surcharges for finished bore H7 and keyway to DIN 6885 part 1

Stück Quantity	Fertigbohrung bis 30 mm Finished bore up to 30 mm		Fertigbohrung 31 bis 50 mm Finished bore 31 to 50 mm		Fertigbohrung 51 bis 75 mm Finished bore 51 to 75 mm		Gewindebohrung für Stellschraube Drilled and tapped for setscrews
	ohne Nut without keyway	mit Nut with keyway	ohne Nut without keyway	mit Nut with keyway	ohne Nut without keyway	mit Nut with keyway	
	€ Stück each	€ Stück each	€ Stück each	€ Stück each	€ Stück each	€ Stück each	€ Stück each
1 bis to 2	auf Anfrage on request						
3 bis to 5							
6 bis to 10							
11 bis to 24							
25 bis to 50							
über over 50							

Sonderbearbeitungen und Sonderscheiben auf Anfrage. Special pulleys and custom designed pulleys on request.

Keilrillenscheiben für Taperbuchsen – Rillen nach DIN 2211

V-grooved pulleys for taper bushes – grooves to ISO/BS/DIN



Profil Section SPZ/10

Richt-durchmesser Datum diameter d_d (mm)	Anzahl der Rillen No. of grooves	Ausführung Type		Gewicht ohne Buchse Weight without bush (\approx kg)	Nabe/Hub		Taper-Buchse Taper bush	€ Stück ohne Buchse each without bush	Richt-durchmesser Datum diameter d_d (mm)	Anzahl der Rillen No. of grooves	Ausführung Type		Gewicht ohne Buchse Weight without bush (\approx kg)	Nabe/Hub		Taper-Buchse Taper bush	€ Stück ohne Buchse each without bush	
					Länge length (mm)	Lage zum Kranz ¹⁾ Position to face ¹⁾								Länge length (mm)	Lage zum Kranz ¹⁾ Position to face ¹⁾			
50▲	1	●	11	0,3	37	v 21	1008		106	1	●	8	0,9	25	bü	1610		
	2	●	11	0,4	49	v 21	1008			2	●	6	1,1	25	rü 3	1610		
56▲	1	●	11	0,4	22	rü 15	1008			3	●	6	1,3	25	rü 15	1610		
	2	●	11	0,5	22	rü 27	1108			4	●	6	1,3	25	rü 27	1610		
60	1	●	11	0,2	22	bü	1008			5	●	6	1,5	32	rü 32	2012		
	2	●	11	0,6	22	rü 27	1108			6	●	6	1,6	32	rü 44	2012		
63	1	●	8	0,2	22	bü	1108		112	1	●	8	1,0	25	bü	1610		
	2	●	6	0,3	22	rü 6	1108			2	●	6	1,3	25	rü 3	1610		
	3	●	6	0,4	22	rü 18	1108			3	●	6	1,3	32	rü 8	2012		
67	1	●	8	0,3	22	bü	1108			4	●	6	1,5	32	rü 20	2012		
	2	●	6	0,4	22	rü 6	1108			5	●	6	1,8	32	rü 32	2012		
	3	●	6	0,5	22	rü 18	1108			6	●	6	1,9	32	rü 44	2012		
71	1	●	8	0,3	22	bü	1108		118	1	●	8	0,9	25	bü	1610		
	2	●	6	0,4	22	rü 6	1108			2	●	6	1,3	25	rü 3	1610		
	3	●	6	0,6	22	rü 18	1108			3	●	6	1,6	32	rü 8	2012		
75	1	●	8	0,4	22	bü	1108			4	●	6	1,8	32	bü	2012		
	2	●	6	0,4	25	rü 3	1210			5	●	6	1,8	32	rü 32	2012		
	3	●	6	0,5	25	rü 15	1210			6	●	6	2,0	45	rü 31	2517		
80	1	●	8	0,5	25	bü	1210	auf Anfrage on request	125	1	●	8	1,0	25	bü	1610	auf Anfrage on request	
	2	●	6	0,6	25	rü 3	1210			2	●	6	1,4	25	rü 3	1610		
	3	●	6	0,7	25	rü 15	1210			3	●	2	1,8	32	rü 8	2012		
	4	●	6	0,8	25	rü 27	1210			4	●	2	2,2	32	bü	2012		
85	1	●	8	0,6	25	bü	1210			5	●	6	2,3	32	rü 32	2012		
	2	●	6	0,5	25	rü 3	1610			6	●	6	2,5	45	rü 31	2517		
	3	●	6	0,6	25	rü 15	1610			132	1	●	8	1,1	25	bü		1610
	4	●	6	0,9	25	rü 27	1610				2	●	6	1,5	25	rü 3		1610
	5	●	6	1,0	25	rü 39	1610				3	●	2	2,3	32	rü 8		2012
90	1	●	8	0,7	25	bü	1210			4	●	2	2,5	32	rü 20	2012		
	2	●	6	0,7	25	rü 3	1610			5	●	6	2,7	45	rü 19	2517		
	3	●	6	0,8	25	rü 15	1610			6	●	6	2,9	45	rü 31	2517		
	4	●	6	1,0	25	rü 27	1610			140	1	●	8	1,2	25	bü		1610
	5	●	6	1,2	25	rü 39	1610				2	●	2	1,7	25	rü 3		1610
95	1	●	8	0,7	25	bü	1210			3	●	2	2,6	32	bü	2012		
	2	●	6	0,8	25	rü 3	1610			4	●	2	2,9	32	bü	2012		
	3	●	6	0,9	25	rü 15	1610			5	●	2	3,2	45	bü	2517		
	4	●	6	1,1	25	rü 27	1610			6	●	2	3,5	45	bü	2517		
	5	●	6	1,3	25	rü 39	1610			8	●	4	4,0	45	rü 27,5	2517		
100	1	●	8	0,8	25	bü	1210		150	1	●	8	1,2	25	bü	1610		
	2	●	6	0,9	25	rü 3	1610			2	●	8	2,0	32	bü	2012		
	3	●	6	1,1	25	rü 15	1610			3	●	2	3,1	32	bü	2012		
	4	●	6	1,1	25	rü 27	1610			4	●	2	3,7	45	bü	2517		
	5	●	6	1,3	32	rü 32	2012			5	●	2	4,0	45	bü	2517		
	6	●	6	1,4	32	rü 44	2012			6	●	2	4,4	45	bü	2517		
									8	●	4	5,1	45	rü 27,5	2517			

▲ nur für Profil 10 only for section 10

bü = bündig / precise
rü = Rücksprung / behind
v = Vorsprung / in front

Anzahl der Rillen No. of grooves z	1	2	3	4	5	6	8
Kranzbreite Face width b_2 (mm)	16	28	40	52	64	76	100
Taperbuchse Taper bush	1008	1108	1210	1610	2012	2517	
Bohrung d_2 (mm) von ... bis ... Bore d_2 (mm) from ... to ...	10-25	10-28	11-32	14-42	14-50	16-60	
€/Stück each	auf Anfrage / on request						

- Vollscheibe Solid pulley
- Bodenscheibe Plate pulley (mit oder ohne Spiegel with or without holes)
- × Armscheibe Spoked pulley

¹⁾ Nebenbezugsfläche: Kleiner \varnothing der Kegelbohrung.
Hub reference edge: small diameter of taper bore.

Material: EN-GJL 200 – DIN EN 1561

Bohrungsdurchmesser d_2 siehe Seite 3-4.
Bore diameters d_2 see page 3-4.

Keilrillenscheiben für Taperbuchsen – Rillen nach DIN 2211 V-grooved pulleys for taper bushes – grooves to ISO/BS/DIN

Profil Section SPZ/10



Richt- durch- messer Datum d _d (mm)	Anzahl der Rillen No. of grooves	Ausfüh- rung Type	Gewicht ohne Buchse Weight without bush (≈ kg)	Nabe/Hub		Taper- Buchse Taper bush	€ Stück ohne Buchse each without bush		Richt- durch- messer Datum d _d (mm)	Anzahl der Rillen No. of grooves	Ausfüh- rung Type	Gewicht ohne Buchse Weight without bush (≈ kg)	Nabe/Hub		Taper- Buchse Taper bush	€ Stück ohne Buchse each without bush	
				Länge length (mm)	Lage zum Kranz ¹⁾ Position to face ¹⁾								Länge length (mm)	Lage zum Kranz ¹⁾ Position to face ¹⁾			
160	1	●	8	1,3	25	bü	1610		280	1	×	7	2,9	32	v 8	2012	
	2	●	8	2,5	32	bü	2012			2	×	7	4,0	32	bü	2012	
	3	●	2	3,6	32	bü	2012			3	×	7	5,3	45	bü	2517	
	4	●	2	4,4	45	bü	2517			4	×	10	6,4	45	rü 3,5	2517	
	5	●	2	4,8	45	bü	2517			5	×	10	7,1	45	rü 9,5	2517	
	6	●	2	5,2	45	bü	2517			6	×	10	7,8	45	rü 15,5	2517	
	8	●	4	5,6	45	rü 27,5	2517			8	×	10	10,8	51	rü 24,5	3020	
	170	1	●	8	1,5	25	bü			1610		315	1	×	7	3,1	
2		●	8	2,5	32	bü	2012	2	×	7			4,2	32	bü	2012	
3		○	9	4,2	32	bü	2012	3	×	7			6,1	45	bü	2517	
4		●	2	5,3	45	bü	2517	4	×	10			7,6	45	rü 3,5	2517	
5		●	2	5,9	45	bü	2517	5	×	10			8,6	45	rü 9,5	2517	
6		●	2	6,5	45	bü	2517	6	×	10			9,3	45	rü 15,5	2517	
180	1	●	8	1,6	25	bü	1610	auf Anfrage on request	355	1	×	7	3,5	32	v 8	2012	auf Anfrage on request
	2	●	8	2,5	32	bü	2012			2	×	7	5,1	32	bü	2012	
	3	○	9	4,8	32	bü	2012			3	×	7	7,3	45	bü	2517	
	4	○	9	6,1	45	bü	2517			4	×	10	8,9	45	rü 3,5	2517	
	5	○	9	6,3	45	bü	2517			5	×	10	10,0	45	rü 9,5	2517	
	6	○	9	6,8	45	bü	2517			6	×	10	10,7	45	rü 15,5	2517	
	8	●	4	7,1	51	rü 24,5	3020			8	×	10	16,0	76	rü 12,0	3030	
	190	1	●	8	1,8	25	bü			1610		400	1	×	7	6,0	
2		●	8	2,6	32	bü	2012	2	×	7			6,3	45	bü	2517	
3		○	9	4,9	32	bü	2012	3	×	7			8,0	45	bü	2517	
4		○	9	5,3	45	bü	2517	4	×	10			10,1	45	rü 3,5	2517	
5		○	9	6,3	45	bü	2517	5	×	10			11,7	51	rü 6,5	3020	
6		○	9	6,9	45	bü	2517	6	×	10			14,5	76	bü	3020	
200	1	●	8	2,3	32	bü	2012		450	1	×	7	6,1	45	v 14,5	2517	
	2	●	8	2,8	32	bü	2012			2	×	7	8,2	45	v 8,5	2517	
	3	○	9	3,5	32	bü	2012			3	×	7	9,8	45	v 2,5	2517	
	4	○	9	4,7	45	rü 3,5	2517			4	×	10	11,8	51	rü 0,5	3020	
	5	○	9	5,5	45	rü 9,5	2517			5	×	10	13,9	51	rü 6,5	3020	
	6	○	9	6,1	45	rü 15,5	2517			6	×	10	16,9	76	bü	3030	
	8	●	4	9,3	51	rü 24,5	3020			8	×	10	24,0	89	rü 5,5	3535	
	224	1	○	5	2,5	32	bü			2012		500	2	×	7	9,1	
2		○	5	3,2	32	bü	2012	3	×	7			11,4	45	v 2,5	2517	
3		○	9	3,9	32	rü 4	2012	4	×	10			14,3	51	rü 0,5	3020	
4		○	9	5,2	45	rü 3,5	2517	5	×	10			17,6	76	v 6	3020	
5		○	9	6,0	45	rü 9,5	2517	6	×	10			19,9	76	bü	3020	
6		○	9	6,6	45	rü 15,5	2517	6	×	10			19,9	76	bü	3020	
8		●	4	11,8	51	rü 24,5	3020	6	×	10			19,9	76	bü	3020	
250		1	×	7	2,8	32	bü	2012		630			3	×	7	15,9	45
	2	×	7	3,5	32	bü	2012	4			×	10	20,0	76	v 12	3020	
	3	×	10	4,3	32	rü 4	2012	5			×	10	22,7	76	v 6	3020	
	4	×	10	5,7	45	rü 3,5	2517	6			×	7	33,6	89	v 6,5	3535	
	5	×	10	6,4	45	rü 9,5	2517										
	6	×	10	7,0	45	rü 15,5	2517										
	8	×	10	10,5	51	rü 24,5	3020										

bü = bündig / precise
rü = Rücksprung / behind
v = Vorsprung / in front

Anzahl der Rillen No. of grooves z	1	2	3	4	5	6	8
Kranzbreite Face width b ₂ (mm)	16	28	40	52	64	76	100
Taperbuchse Taper bush	1610	2012	2517	3020	3030	3535	
Bohrung d ₂ (mm) von ... bis ... Bore d ₂ (mm) from ... to ...	14-42	14-50	16-60	25-75	35-75	35-90	
€/Stück each	auf Anfrage / on request						

● Vollscheibe Solid pulley
○ Bodenscheibe Plate pulley
(mit oder ohne Spiegel with or without holes)
× Armscheibe Spoked pulley
¹⁾ Nebenbezugskante: Kleiner ø der Kegelbohrung.
Hub reference edge: small diameter of taper bore.
Material: EN-GJL 200 – DIN EN 1561
Bohrungsdurchmesser d₂ siehe Seite 3-4.
Bore diameters d₂ see page 3-4.

Keilrillenscheiben für Taperbuchsen – Rillen nach DIN 2211

V-grooved pulleys for taper bushes – grooves to ISO/BS/DIN



Profil Section SPA/13

Richt-durchmesser Datum diameter d_d (mm)	Anzahl der Rillen No. of grooves	Ausführung Type		Gewicht ohne Buchse Weight without bush (\approx kg)	Nabe/Hub		Taper-Buchse Taper bush	€ Stück ohne Buchse each without bush	Richt-durchmesser Datum diameter d_d (mm)	Anzahl der Rillen No. of grooves	Ausführung Type		Gewicht ohne Buchse Weight without bush (\approx kg)	Nabe/Hub		Taper-Buchse Taper bush	€ Stück ohne Buchse each without bush
		●	○		Länge length (mm)	Lage zum Kranz ¹⁾ Position to face ¹⁾					Länge length (mm)	Lage zum Kranz ¹⁾ Position to face ¹⁾					
63▲	1	●	11	0,6	40	v 20	1108		125	1	●	8	1,4	25	bü	1610	
	2	●	11	0,8	55	v 20	1108			2	●	2	1,7	25	bü	1610	
67▲	1	●	8	0,3	22	bü	1108			3	●	2	2,0	32	bü	2012	
	2	●	6	0,5	22	rü 13	1108			4	●	2	2,5	32	bü	2012	
71▲	1	●	8	0,3	22	bü	1108		132	1	●	8	1,6	25	bü	1610	
	2	●	6	0,5	22	rü 13	1108			2	●	2	1,8	32	bü	2012	
	3	●	6	0,7	22	rü 28	1108			3	●	2	2,3	32	bü	2012	
75▲	1	●	8	0,4	22	bü	1108		140	4	●	2	2,6	45	bü	2517	
	2	●	6	0,6	25	rü 13	1108			5	●	2	2,9	45	bü	2517	
	3	●	6	0,8	25	rü 28	1108			1	●	8	1,8	25	bü	1610	
80▲	1	●	8	0,5	25	bü	1210		150	2	●	2	2,4	32	rü 3	2012	
	2	●	6	0,6	25	rü 10	1210			3	●	2	3,5	45	bü	2517	
	3	●	6	0,9	25	rü 25	1210			4	●	2	3,8	45	bü	2517	
85	1	●	8	0,6	25	bü	1210		160	5	●	2	4,2	45	bü	2517	
	2	●	6	0,7	25	rü 10	1210			1	○	5	1,9	25	bü	1610	
	3	●	6	1,1	25	rü 25	1610			2	●	2	2,9	32	rü 3	2012	
90	3	●	6	1,0	25	rü 25	1610		170	3	●	2	3,9	45	bü	2517	
	4	●	6	1,2	38	rü 27	1615			4	●	2	4,4	45	bü	2517	
	1	●	8	0,8	25	bü	1210			5	●	2	5,1	45	bü	2517	
	2	●	6	0,9	25	rü 10	1610			1	○	5	2,0	25	bü	1610	
95	3	●	6	1,4	38	rü 27	1615		180	2	●	2	3,1	32	bü	2012	
	4	●	6	1,4	38	rü 27	1615			3	●	2	4,6	45	bü	2517	
	1	●	8	0,8	25	bü	1210			4	●	2	5,5	45	bü	2517	
	2	●	6	0,9	25	rü 10	1610			5	●	2	5,9	45	bü	3020	
100	3	●	6	1,1	25	rü 25	1610		190	1	○	5	2,1	25	bü	1610	
	4	●	6	1,4	38	rü 27	1615			2	○	9	3,4	32	rü 3	2012	
	1	●	8	0,8	25	bü	1610			3	●	2	5,1	45	bü	2517	
	2	●	6	0,9	25	rü 10	1610			4	●	2	5,9	45	bü	2517	
	3	●	2	1,2	25	rü 25	1610			5	●	2	6,2	51	bü	3020	
106	4	●	2	1,7	38	rü 27	1610		200	1	○	5	2,3	25	bü	1610	
	5	●	6	1,9	38	rü 42	1610			2	○	9	3,8	32	bü	2012	
	1	●	8	0,9	25	bü	1610			3	●	2	5,4	45	bü	2517	
	2	●	6	1,1	25	rü 10	1610			4	●	2	6,8	45	bü	2517	
	3	●	6	1,3	32	rü 18	2012			5	●	2	7,4	52	bü	3020	
112	4	●	6	1,9	32	rü 33	2012			1	○	5	2,6	32	bü	1610	
	5	●	6	2,1	32	rü 48	2012			2	○	5	4,1	45	bü	2517	
	1	●	8	1,0	25	bü	1610			3	○	9	4,9	45	bü	2517	
	2	●	6	1,2	25	rü 10	1610			4	●	2	7,4	51	bü	3020	
	3	●	6	1,4	25	rü 10	1610			5	●	4	8,4	51	bü	3020	
118	4	●	2	2,0	32	rü 33	2012			1	○	5	2,6	32	bü	1610	
	5	●	2	2,4	32	rü 48	2012			2	○	5	4,1	45	bü	2517	
	1	●	8	1,2	25	bü	1610			3	○	9	4,9	45	bü	2517	
	2	●	6	1,4	25	rü 10	1610			4	●	2	7,4	51	bü	3020	
	3	●	2	1,8	32	rü 18	2012			5	●	4	8,4	51	bü	3020	

auf Anfrage on request

auf Anfrage on request

▲ nur für Profil 13 only for section 13

bü = bündig / precise
rü = Rücksprung / behind
v = Vorsprung / in front

Anzahl der Rillen No. of grooves z	1	2	3	4	5		
Kranzbreite Face width b_2 (mm)	20	35	50	65	80		
Taperbuchse Taper bush	1108	1210	1610	1615	2012	2517	3020
Bohrung d_2 (mm) von ... bis ... Bore d_2 (mm) from ... to ...	10-28	11-32	14-42	14-42	14-50	16-60	25-75
€/Stück each	auf Anfrage / on request						

- Vollscheibe Solid pulley
- Bodenscheibe Plate pulley (mit oder ohne Spiegel with or without holes)
- × Armscheibe Spoked pulley

¹⁾ Nebenbezugsfläche: Kleiner \varnothing der Kegelbohrung.
Hub reference edge: small diameter of taper bore.

Material: EN-GJL 200 – DIN EN 1561

Bohrungsdurchmesser d_2 siehe Seite 3-4.
Bore diameters d_2 see page 3-4.

Keilrillenscheiben für Taperbuchsen – Rillen nach DIN 2211 V-grooved pulleys for taper bushes – grooves to ISO/BS/DIN

Profil Section SPA/13



Richt-durchmesser Datum diameter d_d (mm)	Anzahl der Rillen No. of grooves	Ausführung Type	Gewicht ohne Buchse Weight without bush (\approx kg)	Nabe/Hub		Taper-Buchse Taper bush	€ Stück ohne Buchse each without bush	Richt-durchmesser Datum diameter d_d (mm)	Anzahl der Rillen No. of grooves	Ausführung Type	Gewicht ohne Buchse Weight without bush (\approx kg)	Nabe/Hub		Taper-Buchse Taper bush	€ Stück ohne Buchse each without bush	
				Länge length (mm)	Lage zum Kranz ¹⁾ Position to face ¹⁾							Länge length (mm)	Lage zum Kranz ¹⁾ Position to face ¹⁾			
212	1	○	5	2,7	32	bü	2012	500	1	×	7	8,0	45	bü	2517	
	2	○	5	4,3	45	bü	2517		2	×	7	11,6	45	bü	2517	
	3	○	9	5,2	45	bü	2517		3	×	7	16,0	51	bü	3020	
	4	●	2	7,3	52	bü	3020		4	×	10	18,2	51	rü 7	3020	
	5	●	2	8,2	52	bü	3020		5	×	7	27,3	89	bü	3535	
224	1	×	7	2,7	32	bü	2012	560	1	×	7	11,6	45	bü	2517	
	2	○	5	4,4	45	bü	2517		2	×	7	15,5	52	bü	3020	
	3	○	9	5,5	45	rü 2,5	2517		3	×	7	17,8	51	bü	3020	
	4	●	2	7,4	51	bü	3020		4	×	7	26,7	89	bü	3535	
	5	●	2	8,3	51	bü	3020		5	×	7	30,4	89	bü	3535	
236	1	×	7	2,8	32	bü	2012	630	1	×	7	10,1	45	bü	2517	
	2	○	5	4,6	45	bü	2517		2	×	7	16,0	51	bü	3020	
	3	○	9	5,7	45	bü	2517		3	×	7	22,0	51	bü	3020	
	4	●	2	7,8	52	bü	3020		4	×	7	30,8	89	bü	3535	
	5	●	2	8,7	52	bü	3020		5	×	7	33,7	89	bü	3535	
250	1	×	7	2,9	32	bü	2012	auf Anfrage on request	280	1	×	7	3,3	32	bü	2012
	2	×	7	4,8	45	bü	2517			2	×	7	5,4	45	bü	2517
	3	○	9	5,9	45	rü 2,5	2517			3	○	9	6,7	45	rü 2,5	2517
	4	○	9	8,0	51	rü 7	3020			4	○	9	8,8	51	rü 7	3020
	5	○	9	9,0	51	rü 14,5	3020			5	○	5	15,5	89	bü	3535
315	1	×	7	3,6	32	bü	2012		355	1	×	7	4,2	32	bü	2012
	2	×	7	6,0	45	bü	2517			2	×	7	6,7	45	bü	2517
	3	○	5	8,3	51	bü	3020			3	×	7	9,2	51	bü	3020
	4	○	9	9,7	51	rü 7	3020			4	×	10	11,0	51	rü 7	3020
	5	○	5	17,0	89	bü	3535			5	×	7	18,6	89	bü	3535
400	1	×	7	4,9	32	bü	2012		450	1	×	7	7,0	32	bü	2012
	2	×	7	8,1	45	bü	2517			2	×	7	10,3	45	bü	2517
	3	×	7	11,0	51	bü	3020			3	×	7	14,1	51	bü	3020
	4	×	10	12,8	51	rü 7	3020			4	×	10	15,5	51	rü 7	3020
	5	×	7	21,0	89	bü	3535			5	×	7	24,3	89	bü	3535

bü = bündig / precise
rü = Rücksprung / behind
v = Vorsprung / in front

Anzahl der Rillen No. of grooves z	1	2	3	4	5
Kranzbreite Face width b_2 (mm)	20	35	50	65	80
Taperbuchse Taper bush	2012	2517	3020	3030	3535
Bohrung d_2 (mm) von ... bis ... Bore d_2 (mm) from ... to ...	14-50	16-60	25-75	35-75	35-90
€/Stück each	auf Anfrage / on request				

- Vollscheibe Solid pulley
- Bodenscheibe Plate pulley (mit oder ohne Spiegel with or without holes)
- ×

¹⁾ Nebenbezugkante: Kleiner \varnothing der Kegelbohrung.
Hub reference edge: small diameter of taper bore.
Material: EN-GJL 200 – DIN EN 1561
Bohrungsdurchmesser d_2 siehe Seite 3-4.
Bore diameters d_2 see page 3-4.

Keilrillenscheiben für Taperbuchsen – Rillen nach DIN 2211

V-grooved pulleys for taper bushes – grooves to ISO/BS/DIN



Profil Section SPB/17

Richt-durchmesser Datum diameter d_d (mm)	Anzahl der Rillen No. of grooves	Ausführung Type		Gewicht ohne Buchse Weight without bush (\approx kg)	Nabe/Hub		Taper-Buchse Taper bush	€ Stück ohne Buchse each without bush	Richt-durchmesser Datum diameter d_d (mm)	Anzahl der Rillen No. of grooves	Ausführung Type		Gewicht ohne Buchse Weight without bush (\approx kg)	Nabe/Hub		Taper-Buchse Taper bush	€ Stück ohne Buchse each without bush
		●	○		Länge length (mm)	Lage zum Kranz ¹⁾ Position to face ¹⁾					Länge length (mm)	Lage zum Kranz ¹⁾ Position to face ¹⁾					
100▲	1	●	1	0,9	25	bü	1610	auf Anfrage on request	180	1	●	1	4,1	25	bü	1610	auf Anfrage on request
	2	●	6	1,2	25	rü 19	1610			2	●	8	4,5	45	bü	2517	
	3	●	6	1,7	25	rü 19	1610			3	●	2	5,5	45	rü 18	2517	
112▲	1	●	1	1,1	25	bü	1610		4	●	4	6,9	45	rü 18,5	2517		
	2	●	6	1,5	25	rü 19	1610		5	●	4	7,1	51	rü 25	3020		
	3	●	6	2,0	25	rü 38	1610		6	●	4	7,7	51	rü 34,5	3020		
118▲	1	●	1	1,3	25	bü	1610		8	●	4	9,5	76	rü 41	3020		
	2	●	6	1,7	25	rü 19	1610		190	1	●	8	4,6	32	bü	2012	
	3	●	6	2,3	25	rü 38	1610			2	●	8	5,0	45	bü	2517	
125▲	1	●	1	1,5	25	bü	1610			3	●	2	6,3	45	rü 18	2517	
	2	●	2	1,9	32	rü 12	2012		4	●	4	7,6	45	rü 18,5	2517		
	3	●	2	2,4	32	rü 31	2012		5	●	4	8,1	51	rü 25	3020		
	4	●	4	3,0	32	rü 50	2012		6	●	4	9,2	51	rü 34,5	3020		
	5	●	6	3,5	32	rü 69	2012		8	●	4	11,2	76	rü 41	3030		
132▲	1	●	1	1,8	25	bü	1610		200	1	●	8	5,0	32	bü	2012	
	2	●	2	2,2	32	rü 12	2012			2	●	8	5,4	45	bü	2517	
	3	●	2	2,8	32	rü 31	2012			3	●	2	6,5	45	bü	2517	
	4	●	4	3,4	32	rü 50	2012			4	●	2	8,8	51	bü	3020	
	5	●	4	3,7	32	rü 34,5	2012	5		●	2	9,1	51	bü	3020		
140	1	●	1	2,3	25	bü	1610	6	●	4	10,3	51	rü 34,5	3020			
	2	●	2	2,7	32	bü	2012	8	●	4	13,5	89	rü 34,5	3535			
	3	●	2	3,3	32	bü	2012	212	1	●	8	4,2	32	bü	2012		
	4	●	2	3,7	45	rü 18,5	2517		2	●	8	4,9	45	bü	2517		
	5	●	2	4,5	45	rü 28	2517		3	●	2	6,0	45	bü	2517		
	6	●	4	4,6	45	rü 36	2517		4	●	2	9,8	51	bü	3020		
150	1	●	1	2,7	25	bü	1610		5	●	2	11,0	51	bü	3020		
	2	●	2	3,1	32	bü	2012		6	●	4	14,3	89	rü 15,5	3535		
	3	●	2	3,9	45	bü	2517	8	●	4	16,6	89	rü 34,5	3535			
	4	●	2	4,4	45	rü 18,5	2517	224	1	●	8	4,7	32	bü	2012		
	5	●	4	5,2	45	rü 28	2517		2	●	8	5,3	45	bü	2517		
	6	●	4	5,6	45	rü 36	2517		3	●	2	6,3	45	bü	2517		
160	1	●	1	2,5	25	bü	1610		4	●	2	11,3	51	bü	3020		
	2	●	2	2,9	32	rü 12	2012		5	●	2	12,7	51	bü	3020		
	3	●	2	4,2	45	rü 18	2517		6	●	4	17,0	89	rü 15,5	3535		
	4	●	4	4,9	45	rü 18,5	2517	8	●	4	19,3	89	rü 34,5	3535			
	5	●	4	6,0	45	rü 28	2517	10	●	4	21,8	89	rü 53,5	3535			
	6	●	4	5,4	51	rü 34,5	3020	236	1	●	8	5,0	32	bü	2012		
170	1	●	1	2,9	25	bü	1610		2	●	8	5,5	45	bü	2517		
	2	●	2	3,3	32	rü 12	2012		3	×	10	7,0	45	bü	2517		
	3	●	2	4,9	45	rü 18	2517		4	×	10	14,5	51	bü	3020		
	4	●	4	5,7	45	rü 18,5	2517		5	●	6	16,9	89	bü	3535		
	5	●	4	6,1	51	rü 25	3020		6	●	4	20,0	89	rü 15,5	3535		
	6	●	4	6,5	51	rü 34,5	3020		8	●	4	22,3	89	rü 34,5	3535		
8	●	4	8,0	76	rü 41	3020	10		●	4	25,3	89	rü 53,5	3535			

▲ nur für Profil 17 only for section 17

bü = bündig / precise
rü = Rücksprung / behind
v = Vorsprung / in front

Anzahl der Rillen No. of grooves z	1	2	3	4	5	6	8	10
Kranzbreite Face width b_2 (mm)	25	44	63	82	101	120	158	196
Taperbuchse Taper bush	1610	2012	2517	3020	3030	3535		
Bohrung d_2 (mm) von ... bis ... Bore d_2 (mm) from ... to ...	14-42	14-50	16-60	25-75	35-75	35-90		
€/Stück each	auf Anfrage / on request							

- Vollscheibe Solid pulley
- Bodenscheibe Plate pulley (mit oder ohne Spiegel with or without holes)
- × Armscheibe Spoked pulley

¹⁾ Neben Bezugskante: Kleiner \varnothing der Kegelbohrung.
Hub reference edge: small diameter of taper bore.
Material: EN-GJL 200 – DIN EN 1561
Bohrungsdurchmesser d_2 siehe Seite 3-4.
Bore diameters d_2 see page 3-4.

Keilrillenscheiben für Taperbuchsen – Rillen nach DIN 2211 V-grooved pulleys for taper bushes – grooves to ISO/BS/DIN

Profil Section SPB/17



Richt-durchmesser Datum diameter d _d (mm)	Anzahl der Rillen No. of grooves	Ausführung Type	Gewicht ohne Buchse Weight without bush (≈ kg)	Nabe/Hub		Taper-Buchse Taper bush	€ Stück ohne Buchse each without bush		Richt-durchmesser Datum diameter d _d (mm)	Anzahl der Rillen No. of grooves	Ausführung Type	Gewicht ohne Buchse Weight without bush (≈ kg)	Nabe/Hub		Taper-Buchse Taper bush	€ Stück ohne Buchse each without bush			
				Länge length (mm)	Lage zum Kranz ¹⁾ Position to face ¹⁾								Länge length (mm)	Lage zum Kranz ¹⁾ Position to face ¹⁾					
250	1	●	8	5,4	32	bü	2012	auf Anfrage on request	355	2	×	7	8,7	51	bü	3020	auf Anfrage on request		
	2	×	7	5,5	45	bü	2517			3	×	10	10,8	51	rü 6	3020			
	3	●	2	7,7	51	bü	3020			4	×	7	18,6	89	bü	3535			
	4	●	2	19,6	51	bü	3020			5	×	10	20,8	89	rü 6	3535			
	5	●	4	21,7	89	bü	3535			6	×	9	22,8	89	rü 15,5	3535			
	6	●	4	23,3	89	rü 15,5	3535			8	×	10	27,0	89	rü 34,5	3535			
	8	●	4	27,5	89	rü 34,5	3535			10	×	10	38,0	102	rü 47	4040			
	10	●	4	29,3	89	rü 53,5	3535			375	2	×	7	9,5				3020	
	265	2	●	7	6,2						2517	3	×	10	11,5	89		bü	3020
		3	○	9	8,0						3020	4	×	10	16,5				3525
4		○	9	9,5			3020	6	×		10	25,0			3535				
6		○	9	16,7			3525	8	×		10	28,0			4040				
8		○	9	24,0			3525	400	2		×	7	10,0	51	bü	3020			
280		1	×	7	6,1	32	bü		2012		3	×	7	18,3	89	bü	3535		
	2	×	7	6,8	45	bü	2517		4		×	7	20,5	89	bü	3535			
	3	×	10	8,6	51	rü 6	3020		5		×	10	23,4	89	rü 6	3535			
	4	○	9	10,1	51	rü 15,5	3020		6		×	10	25,1	89	rü 15,5	3535			
	5	○	9	17,8	89	rü 6	3535		8	×	10	36,5	102	rü 28	4040				
	6	○	9	19,6	89	rü 15,5	3535	10	×	10	41,0	102	rü 47	4040					
	8	○	9	26,7	89	rü 34,5	3535	425	2	×	7	11,5			3020				
	10	○	9	30,5	89	rü 53,5	3535		3	×	7	18,0			3535				
300	2	×	7	7,3	45	v 0,5	2517	4	×	7	19,5			3535					
	3	×	10	9,2	51	rü 6	3020	6	×	10	25,1			4040					
	4	○	9	14,3	51	rü 15,5	3020	8	×	10	52,5			4545					
	5	○	9	18,2	89	rü 6	3535	450	2	×	7	12,1	51	bü	3020				
6	○	9	21,9	89	rü 15,5	3535	3		×	7	21,9	89	bü	3535					
8	○	9	26,2	89	rü 34,5	3535	4		×	7	24,5	89	bü	3535					
315	1	×	7	7,2	32	bü	2012		5	×	10	27,3	89	rü 6	3535				
	2	×	7	7,8	45	bü	2517		6	×	10	35,5	102	rü 9	4040				
	3	×	10	9,6	51	rü 6	3020		8	×	10	40,9	102	rü 28	4040				
	4	○	5	17,1	89	bü	3535	10	×	10	53,5	104	rü 41	4545					
	5	○	9	18,8	89	rü 6	3535	500	2	×	7	13,2	51	bü	3020				
	6	○	9	23,0	89	rü 15,5	3535		3	×	7	23,1	89	bü	3535				
	8	○	9	26,0	89	rü 34,5	3535		4	×	7	26,6	89	bü	3535				
	10	○	9	31,5	89	rü 53,5	3535		5	×	10	29,9	89	rü 6	3535				
335	2	×	7	7,8	45	bü	2517		6	×	10	38,9	102	rü 9	4040				
	3	×	10	10,5	51	rü 6	3020		8	×	10	45,5	102	rü 28	4040				
	4	×	7	18,3	89	v 3,5	3535	10	×	10	61,0	114	rü 41	4545					
	5	×	10	19,5	89	rü 6	3535	560	2	×	7	16,5	51	v 35	3030				
	6	×	10	22,0	89	rü 15,5	3535		3	×	7	25,9	89	bü	3535				
	8	×	10	28,2	89	rü 34,5	3535		4	×	7	29,0	89	bü	3535				
	10	×	10	36,0	102	rü 47	4040		5	×	7	35,3	102	bü	4040				
									6	×	10	43,1	102	rü 9	4040				
									8	×	10	49,0	114	rü 22	4545				
								10	×	10	55,7	114	rü 41	4545					

bü = bündig / precise
rü = Rücksprung / behind
v = Vorsprung / in front

Anzahl der Rillen No. of grooves z	1	2	3	4	5	6	8	10
Kranzbreite Face width b ₂ (mm)	25	44	63	82	101	120	158	196
Taperbuchse Taper bush	2012	2517	3020	3030	3535	4040	4545	
Bohrung d ₂ (mm) von ... bis ... Bore d ₂ (mm) from ... to ...	14-50	16-60	25-75	35-75	35-90	40-100	55-110	
€/Stück each	auf Anfrage / on request							

● Vollscheibe Solid pulley
○ Bodenscheibe Plate pulley (mit oder ohne Spiegel with or without holes)
× Armscheibe Spoked pulley
¹⁾ Nebenbezugskante: Kleiner ø der Kegelbohrung.
Hub reference edge: small diameter of taper bore.
Material: EN-GJL 200 – DIN EN 1561
Bohrungsdurchmesser d₂ siehe Seite 3-4.
Bore diameters d₂ see page 3-4.

Keilrillenscheiben für Taperbuchsen – Rillen nach DIN 2211

V-grooved pulleys for taper bushes – grooves to ISO/BS/DIN



Profil Section SPB/17

Richt- durch- messer Datum d _d (mm)	Anzahl der Rillen No. of grooves	Ausfüh- rung Type		Gewicht ohne Buchse Weight without bush (≈ kg)	Nabe/Hub		Taper- Buchse Taper bush	€ Stück ohne Buchse each without bush		Richt- durch- messer Datum d _d (mm)	Anzahl der Rillen No. of grooves	Ausfüh- rung Type		Gewicht ohne Buchse Weight without bush (≈ kg)	Nabe/Hub		Taper- Buchse Taper bush	€ Stück ohne Buchse each without bush
					Länge length (mm)	Lage zum Kranz ¹⁾ Position to face ¹⁾									Länge length (mm)	Lage zum Kranz ¹⁾ Position to face ¹⁾		
630	2	×	7	18,5	76	v 16	3020	auf Anfrage on request		900	3	×	7	46,8			3535	auf Anfrage on request
	3	×	7	28,9	89	bü	3535				4	×	7	60,0	102	bü	4040	
	4	×	7	33,3	89	bü	3535				5	×	7	74,8	114	bü	4545	
	5	×	7	43,1	102	bü	4040				6	×	10	81,5	114	rü 3	4545	
	6	×	10	49,2	102	rü 9	4040				8	×	10	110,0	114	rü 22	4545	
	8	×	10	62,0	114	rü 22	4545				10	×	10	126,0	127	rü 34,5	5050	
	10	×	10	72,0	114	rü 41	4545				1000	3	×	7	56,5			
710	3	×	7	33,2	89	bü	3535			4		×	7	66,5	102	bü	4040	
	4	×	7	39,1	89	bü	3535			5		×	7	80,5	114	bü	4545	
	5	×	7	50,2	102	bü	4040			6		×	10	90,0	114	rü 3	4545	
	6	×	10	62,3	114	rü 3	4545			8		×	10	132,0	127	rü 15,5	5050	
	8	×	10	71,0	114	rü 22	4545			10		×	10	147,0	127	rü 34,5	5050	
	10	×	10	80,0	114	rü 41	4545			800		3	×	7	36,7	89	bü	
4	×	7	48,8	102	bü	4040	4				×	7	48,8	102	bü	4040		
5	×	7	56,1	102	bü	4040	5	×	7		56,1	102	bü	4040				
6	×	10	71,4	114	rü 3	4545	6	×	10		71,4	114	rü 3	4545				
8	×	10	90,9	114	rü 22	4545	8	×	10		90,9	114	rü 22	4545				
10	×	10	102,0	114	rü 41	4545	10	×	10		102,0	114	rü 41	4545				

bü = bündig / precise
 rü = Rücksprung / behind
 v = Vorsprung / in front

Anzahl der Rillen No. of grooves z	2	3	4	5	6	8	10
Kranzbreite Face width b ₂ (mm)	44	63	82	101	120	158	196
Taperbuchse Taper bush	3020	3030	3535	4040	4545	5050	
Bohrung d ₂ (mm) von ... bis ... Bore d ₂ (mm) from ... to ...	25-75	35-75	35-90	40-100	55-110	70-125	
€/Stück each	auf Anfrage / on request						

- Vollscheibe Solid pulley
- Bodenscheibe Plate pulley
(mit oder ohne Spiegel with or without holes)
- × Armscheibe Spoked pulley

¹⁾ Nebenbezugkante: Kleiner ø der Kegelbohrung.
 Hub reference edge: small diameter of taper bore.

Material: EN-GJL 200 – DIN EN 1561

Bohrungsdurchmesser d₂ siehe Seite 3-4.
 Bore diameters d₂ see page 3-4.

Keilrillenscheiben für Taperbuchsen – Rillen nach DIN 2211

V-grooved pulleys for taper bushes – grooves to ISO/BS/DIN



Profil Section SPC/22

Richt-durchmesser Datum diameter d_d (mm)	Anzahl der Rillen No. of grooves	Ausführung Type		Gewicht ohne Buchse Weight without bush (\approx kg)	Nabe/Hub		Taper-Buchse Taper bush	€ Stück ohne Buchse each without bush	Richt-durchmesser Datum diameter d_d (mm)	Anzahl der Rillen No. of grooves	Ausführung Type		Gewicht ohne Buchse Weight without bush (\approx kg)	Nabe/Hub		Taper-Buchse Taper bush	€ Stück ohne Buchse each without bush		
					Länge length (mm)	Lage zum Kranz ¹⁾ Position to face ¹⁾								Länge length (mm)	Lage zum Kranz ¹⁾ Position to face ¹⁾				
500	3	×	7	30,9	89	v 2	3535	auf Anfrage on request	800	3	×	7	72,0	127	v 8,25	4545	auf Anfrage on request		
	4	×	10	39,0	89	rü 11	3535			4	×	7	90,8			127		5050	
	5	×	10	48,7	102	rü 17	4040			5	×	10	102,5			127		5050	
	6	×	10	60,2	115	rü 24	4545			6	×	10	113,7			127		5050	
	8	×	9	87,4	127	rü 43	5050			8	×	10	136,6			127		5050	
10	○	9	127,0	127	rü 68	5050	10		○	9	160,7	127	5050						
560	3	×	7	36,0	102	rü 4	3535		auf Anfrage on request	1000	5	×	10	134,0	127	rü 4,5		5050	auf Anfrage on request
	4	×	10	50,0		rü 11	4040				6	×	10	150,0	127	rü 17		5050	
	5	×	10	63,0		rü 17	4545				8	×	10	181,4	127	rü 43		5050	
	6	×	10	77,0		rü 43	5050				10	○	9	217,2	127	rü 68		5050	
	8	×	10	94,0		rü 68	5050				1250	5	×	10	177,6	127		rü 4,5	
10	○	9	115,0	127	rü 68	5050	6			×		10	201,4	127	rü 17	5050			
630	3	×	7	48,5	102	v 8,5	4040			8		×	10	243,7	127	rü 43		5050	
	4	×	7	61,0	119	v 1,5	4545			10		○	9	292,1	127	rü 68		5050	
	5	×	10	77,0	127	rü 4,5	5050			710		3	×	7	62,5	127		rü 4,5	
	6	×	10	86,0	127	rü 17	5050	4			×	7	78,6	4545					
	8	×	10	105,5	127	rü 43	5050	5			×	10	89,6	127	rü 17		5050		
10	○	9	130,0	127	rü 68	5050	6	×			10	99,4	127	rü 43	5050				
3	×	7	62,5	127	rü 68	4040	8	×			10	117,5	127	rü 43	5050				
4	×	7	78,6			4545													
5	×	10	89,6			127	rü 4,5	5050		10	○	9	137,1	127	rü 68	5050			
6	×	10	99,4			127	rü 17	5050											
8	×	10	117,5			127	rü 43	5050											
10	○	9	137,1	127	rü 68	5050													

bü = bündig / precise
 rü = Rücksprung / behind
 v = Vorsprung / in front

Anzahl der Rillen No. of grooves z	3	4	5	6	8	10
Kranzbreite Face width b_2 (mm)	85	110,5	136	161,5	212,5	263,5
Taperbuchse Taper bush	3535	4040	4545	5050		
Bohrung d_2 (mm) von ... bis ... Bore d_2 (mm) from ... to ...	35-90	40-100	55-110	70-125		
€/Stück each	auf Anfrage / on request					

- Vollscheibe Solid pulley
- Bodenscheibe Plate pulley (mit oder ohne Spiegel with or without holes)
- × Armscheibe Spoked pulley

¹⁾ Nebenbezugkante: Kleiner \varnothing der Kegelbohrung.
 Hub reference edge: small diameter of taper bore.

Material: EN-GJL 200 – DIN EN 1561
 Bohrungsdurchmesser d_2 siehe Seite 3-4.
 Bore diameters d_2 see page 3-4.

Keilrillenscheiben für zylindrische Bohrung – Rillen nach DIN 2211 V-grooved pulleys for plain boring – grooves to ISO/BS/DIN

Profil Section SPZ/10

Richtdurchmesser Datum diameter d_d (mm)	Anzahl der Rillen No. of grooves	Ausführung Type	Gewicht Weight (\approx kg)	Fertigbohrung Finished bore d_{max} (mm)	Nabenlänge Hub length l (mm)	€ Stück zentriert each centered	Richtdurchmesser Datum diameter d_d (mm)	Anzahl der Rillen No. of grooves	Ausführung Type	Gewicht Weight (\approx kg)	Fertigbohrung Finished bore d_{max} (mm)	Nabenlänge Hub length l (mm)	€ Stück zentriert each centered																							
45▲	1	○	0,2	16	24	auf Anfrage on request	140	1	○	0,9	28	24	auf Anfrage on request																							
	2	○	0,3	16	35			2	○	1,4	38	38																								
	3	○	0,4	16	35			3	○	1,7	38	40																								
50▲	1	○	0,3	20	24		150	1	×	1,1	28	24		auf Anfrage on request																						
	2	○	0,4	20	35			2	○	1,5	38	38																								
	3	○	0,5	20	40			3	○	1,9	38	40																								
56▲	1	○	0,3	20	24		160	1	×	1,2	32	30			auf Anfrage on request																					
	2	○	0,5	25	35			2	×	1,6	38	38																								
	3	○	0,7	25	40			3	×	2,4	42	40																								
63	1	○	0,3	25	24		170	1	×	1,7	40	30				auf Anfrage on request																				
	2	○	0,6	25	35			2	×	1,9	40	38																								
	3	○	0,9	25	40			3	×	3,0	42	40																								
71	1	○	0,3	25	24		180	1	×	2,1	32	30					auf Anfrage on request																			
	2	○	0,6	25	35			2	×	3,1	38	38																								
	3	○	1,0	30	40			3	×	3,5	42	40																								
75	1	○	0,4	24	24		190	1	×	2,3	35	30						auf Anfrage on request																		
	2	○	0,6	24	35			2	×	2,4	35	38																								
	3	○	1,1	28	40			3	×	4,0	35	40																								
80	1	○	0,4	25	24		200	1	×	2,4	32	38							auf Anfrage on request																	
	2	○	0,7	30	35			2	×	2,9	38	38																								
	3	○	1,1	38	35			3	×	4,5	42	40																								
85	1	○	0,3	25	24		212	1	×	2,6	35	30								auf Anfrage on request																
	2	○	0,7	30	35			2	×	3,4	35	38																								
	3	○	1,1	38	35			3	×	5,0	38	40																								
90	1	○	0,4	25	24		225	1	×	2,8	32	38									auf Anfrage on request															
	2	○	0,8	30	35			2	×	4,0	38	38																								
	3	○	1,2	38	38			3	×	5,3	42	40																								
95	1	○	0,4	28	24		250	1	×	3,3	32	38										auf Anfrage on request														
	2	○	0,8	28	35			2	×	4,8	38	38																								
	3	○	1,2	38	38			3	×	6,0	42	40																								
100	1	○	0,5	28	24	280	1	×	3,9	35	34	auf Anfrage on request																								
	2	○	0,9	30	35		2	×	5,2	42	38																									
	3	○	1,3	38	38		3	×	7,0	48	40																									
106	1	○	0,5	30	24	315	1	×	4,4	35	34		auf Anfrage on request																							
	2	○	1,0	28	35		2	×	6,8	42	38																									
	3	○	1,3	38	38		3	×	8,3	48	40																									
112	1	○	0,5	28	24	355	1	×	4,6	35	34			auf Anfrage on request																						
	2	○	1,0	30	35		2	×	8,0	42	40																									
	3	○	1,4	38	38		3	×	10,0	48	45																									
118	1	○	0,6	28	24	auf Anfrage on request	auf Anfrage on request	auf Anfrage on request	auf Anfrage on request	auf Anfrage on request	auf Anfrage on request				auf Anfrage on request	auf Anfrage on request																				
	2	○	1,1	38	35																															
	3	○	1,5	38	38																															
125	1	○	0,7	28	24												auf Anfrage on request						auf Anfrage on request	auf Anfrage on request	auf Anfrage on request	auf Anfrage on request	auf Anfrage on request	auf Anfrage on request	auf Anfrage on request							
	2	○	1,2	38	35																															
	3	○	1,6	38	40																															
132	1	○	0,8	30	24													auf Anfrage on request												auf Anfrage on request	auf Anfrage on request	auf Anfrage on request	auf Anfrage on request	auf Anfrage on request	auf Anfrage on request	auf Anfrage on request
	2	○	1,3	38	35																															
	3	○	1,6	40	40																															

▲ nur für Profil 10 only for section 10

Anzahl der Rillen No. of grooves z	1	2	3
Kranzbreite Face width b_2 (mm)	16	28	40

- Vollscheibe Solid pulley
 - Bodenscheibe Plate pulley (mit oder ohne Spiegel with or without holes)
 - × Armscheibe Spoked pulley
- Nabenlage: einseitig bündig
Hub position: one side flush
Material: EN-GJL 200 – DIN EN 1561

Keilrillenscheiben für zylindrische Bohrung – Rillen nach DIN 2211 V-grooved pulleys for plain boring – grooves to ISO/BS/DIN

Profil Section SPA/13

Richtdurchmesser Datum diameter d_d (mm)	Anzahl der Rillen No. of grooves	Ausführung Type	Gewicht Weight (\approx kg)	Fertigbohrung Finished bore d_{max} (mm)	Nabenlänge Hub length (mm)	€ Stück zentriert each centered
50▲	1	○	0,3	18	34	auf Anfrage on request
	2	○	0,5	18	49	
	3	○	0,6	18	47	
56▲	1	○	0,4	20	34	
	2	○	0,6	20	49	
	3	○	0,7	20	47	
63▲	1	○	0,5	25	34	
	2	○	0,8	25	49	
	3	○	0,9	25	47	
	4∇	○	1,2	25	60	
	5∇	○	1,5	25	70	
71▲	1	○	0,5	25	34	
	2	○	0,9	28	49	
	3	○	1,0	32	42	
	4∇	○	1,5	32	60	
	5∇	○	1,8	32	70	
75▲	1	○	0,5	24	34	
	2	○	1,0	24	49	
	3	○	1,1	24	42	
	4∇	○	1,8	24	60	
	5∇	○	1,9	28	82	
80▲	1	○	0,6	28	34	
	2	○	1,0	32	49	
	3	○	1,2	38	42	
	4∇	○	1,9	38	60	
	5∇	○	2,0	38	55	
85	1	○	0,6	24	34	
	2	○	1,2	28	49	
	3	○	1,4	28	42	
	4∇	○	2,0	28	53	
	5∇	○	2,2	32	55	
90	1	○	0,9	28	34	
	2	○	1,5	32	49	
	3	○	1,6	38	42	
	4∇	○	2,2	42	53	
	5∇	○	2,5	42	67	
95	1	○	0,8	28	34	
	2	○	1,6	28	49	
	3	○	1,9	28	42	
	4∇	○	2,5	32	53	
	5∇	○	2,8	35	67	
100	1	○	0,8	28	34	
	2	○	1,4	32	49	
	3	○	2,0	38	42	
	4∇	○	2,7	42	53	
	5∇	○	3,1	42	60	

▲ nur für Profil 13 only for section 13

Richtdurchmesser Datum diameter d_d (mm)	Anzahl der Rillen No. of grooves	Ausführung Type	Gewicht Weight (\approx kg)	Fertigbohrung Finished bore d_{max} (mm)	Nabenlänge Hub length (mm)	€ Stück zentriert each centered
106	1	○	0,9	28	34	auf Anfrage on request
	2	○	1,7	28	49	
	3	○	2,2	32	42	
	4∇	○	3,2	32	53	
	5∇	○	3,9	35	60	
112	1	○	1,1	28	34	
	2	○	1,8	38	49	
	3	○	2,4	38	42	
	4∇	○	3,4	42	53	
	5∇	○	4,0	42	60	
118	1	○	1,1	32	34	
	2	○	1,8	38	49	
	3	○	2,4	42	42	
	4∇	○	3,4	42	53	
	5∇	○	4,1	48	65	
125	1	○	1,4	32	34	
	2	○	1,9	38	49	
	3	○	2,6	42	42	
	4∇	○	3,5	42	53	
	5∇	○	4,4	48	65	
132	1	○	1,5	32	34	
	2	○	2,2	38	49	
	3	○	2,6	42	42	
	4∇	○	3,6	42	53	
	5∇	○	4,8	48	65	
140	1	○	1,5	32	34	
	2	○	2,3	38	49	
	3	○	2,6	42	42	
	4∇	○	3,7	42	53	
	5∇	○	5,0	48	65	
150	1	×	1,6	38	36	
	2	×	2,6	38	49	
	3	○	3,0	42	42	
	4∇	○	4,0	42	53	
	5∇	○	5,2	48	65	
160	1	×	1,8	38	36	
	2	×	2,4	38	49	
	3	×	2,8	42	42	
	4∇	○	3,6	48	60	
	5∇	○	5,5	48	70	
170	1	×	2,0	35	36	
	2	×	2,9	35	49	
	3	×	3,2	35	42	
	4∇	×	4,2	35	60	
	5∇	×	5,8	38	70	

∇ $d_d + 4$ mm

Anzahl der Rillen No. of grooves z	1	2	3	4	5
Kranzbreite Face width b_2 (mm)	20	35	50	67	82

- Vollscheibe Solid pulley
 - Bodenscheibe Plate pulley (mit oder ohne Spiegel with or without holes)
 - × Armscheibe Spoked pulley
- Nabenlage: einseitig bündig
Hub position: one side flush
Material: EN-GJL 200 – DIN EN 1561

Keilrillenscheiben für zylindrische Bohrung – Rillen nach DIN 2211 V-grooved pulleys for plain boring – grooves to ISO/BS/DIN

Profil Section SPA/13

Richtdurchmesser Datum diameter d_d (mm)	Anzahl der Rillen No. of grooves	Ausführung Type	Gewicht Weight (\approx kg)	Fertigbohrung Finished bore d_{max} (mm)	Nabenlänge Hub length (mm)	€ Stück zentriert each centered	Richtdurchmesser Datum diameter d_d (mm)	Anzahl der Rillen No. of grooves	Ausführung Type	Gewicht Weight (\approx kg)	Fertigbohrung Finished bore d_{max} (mm)	Nabenlänge Hub length (mm)	€ Stück zentriert each centered
180	1	×	2,0	38	36	auf Anfrage on request	315	1	×	4,8	48	44	auf Anfrage on request
	2	×	3,2	42	49			2	×	6,6	48	53	
	3	×	3,6	42	42			3	×	8,8	55	47	
	4 ∇	×	4,7	48	60			4 ∇	×	11,1	55	60	
	5 ∇	×	6,1	48	70			5 ∇	×	12,5	60	70	
190	1	×	2,0	38	36		355	1	×	5,5	48	44	
	2	×	3,2	42	49			2	×	7,7	55	53	
	3	×	4,0	42	42			3	×	9,6	55	47	
	4 ∇	×	5,2	48	60			4 ∇	×	11,8	55	60	
	5 ∇	×	6,3	48	70			5 ∇	×	13,8	60	70	
200	1	×	2,4	38	36		400	1 ∇	×	6,9	50	50	
	2	×	2,9	42	49			3 ∇	×	10,5	60	47	
	3	×	4,2	48	42			4 ∇	×	12,4	60	67	
	4 ∇	×	5,0	55	60			5 ∇	×	15,9	60	82	
	5 ∇	×	6,5	55	70			450	1 ∇	×	7,5	55	
212	1	×	2,7	40	36	2 ∇	×		9,4	55	53		
	2	×	3,4	42	49	3 ∇	×		12,2	60	47		
	3	×	4,4	42	42	4 ∇	×		14,2	65	67		
	4 ∇	×	5,7	42	60	5 ∇	×		18,3	65	82		
	5 ∇	×	6,9	42	70	500	2 ∇	×	10,7	55	55		
225	1	×	2,8	40	36		3 ∇	×	13,5	60	60		
	2	×	3,9	42	49		4 ∇	×	16,3	65	67		
	3	×	4,6	42	42		5 ∇	×	22,8	65	82		
	4 ∇	×	6,5	42	60		560	1 ∇	×	14,0	55	60	
	5 ∇	×	7,3	42	70	2 ∇		×	13,1	55	60		
236	1	×	3,3	38	36	3 ∇		×	15,6	60	74		
	2	×	4,1	42	49	4 ∇		×	19,4	65	67		
	3	×	4,9	48	47								
	4 ∇	×	6,2	55	60								
	5 ∇	×	7,5	55	70								
250	1	×	3,4	42	36								
	2	×	4,3	48	49								
	3	×	5,3	48	47								
	4 ∇	×	7,0	55	60								
	5 ∇	×	7,9	60	70								
280	1	×	3,9	42	44								
	2	×	5,4	48	53								
	3	×	6,5	48	47								
	4 ∇	×	8,5	55	60								
	5 ∇	×	9,9	60	70								
300	1	×	4,3	48	44								
	2	×	5,9	48	53								
	3	×	7,5	55	47								
	4 ∇	×	9,8	55	60								
	5 ∇	×	11,3	60	70								
$\nabla d_d + 4 \text{ mm}$													

Anzahl der Rillen No. of grooves z	1	2	3	4	5
Kranzbreite Face width b_2 (mm)	20	35	50	67	82

- Vollscheibe Solid pulley
 - Bodenscheibe Plate pulley (mit oder ohne Spiegel with or without holes)
 - × Armscheibe Spoked pulley
- Nabenlage: einseitig bündig
Hub position: one side flush
Material: EN-GJL 200 – DIN EN 1561

Keilrillenscheiben für zylindrische Bohrung – Rillen nach DIN 2211 V-grooved pulleys for plain boring – grooves to ISO/BS/DIN

Profil Section SPB/17

Richtdurchmesser Datum diameter d_d (mm)	Anzahl der Rillen No. of grooves	Ausführung Type	Gewicht Weight (\approx kg)	Fertigbohrung Finished bore d_{max} (mm)	Nabenslänge Hub length (mm)	€ Stück zentriert each centered	Richtdurchmesser Datum diameter d_d (mm)	Anzahl der Rillen No. of grooves	Ausführung Type	Gewicht Weight (\approx kg)	Fertigbohrung Finished bore d_{max} (mm)	Nabenslänge Hub length (mm)	€ Stück zentriert each centered						
56▲	1	○	0,6	20	41	auf Anfrage on request	112▲	1	○	1,5	32	41	auf Anfrage on request						
	2	○	1,0	20	60			2	○	2,4	38	60							
	3	○	1,1	22	62			3	○	3,1	38	55							
63▲	1	○	0,8	20	41		4v	○	4,8	42	67	118▲		1	○	1,6	32	41	
	2	○	1,2	20	60		5v	○	5,6	42	75			2	○	2,4	38	60	
	3	○	1,2	22	62		6v	○	6,2	42	85			3	○	3,2	42	55	
71▲	1	○	0,8	22	41		75▲	1	○	0,8	25	41		125▲	1	○	1,7	32	41
	2	○	1,3	22	60			2	○	1,4	25	60			2	○	2,6	38	60
	3	○	1,6	22	55			3	○	1,9	25	62			3	○	3,3	42	55
80▲	1	○	1,0	28	41		85▲	1	○	1,1	30	41		132▲	1	○	1,9	30	41
	2	○	1,7	28	60			2	○	1,7	30	60			2	○	2,6	30	60
	3	○	2,1	28	55			3	○	2,2	30	55			3	○	3,5	42	55
	4v	○	2,4	28	70			4v	○	2,7	30	70			4v	○	6,3	42	70
	5v	○	2,7	28	80			5v	○	3,0	30	75			5v	○	9,4	42	75
90▲	1	○	1,2	32	41	95▲	1	○	1,3	35	41	140	1	○	2,1	32	41		
	2	○	1,8	38	60		2	○	2,0	38	60		2	○	2,9	38	60		
	3	○	2,3	38	55		3	○	2,5	38	67		3	○	3,9	42	55		
	4v	○	3,1	38	70		4v	○	3,3	38	75		4v	○	6,9	42	70		
	5v	○	3,3	38	75		5v	○	2,5	38	75		5v	○	7,6	48	75		
100▲	1	○	1,3	32	41	106▲	1	○	1,5	28	41	150	1	○	2,4	32	43		
	2	○	2,1	38	60		2	○	2,0	28	60		2	○	3,2	38	48		
	3	○	2,9	38	55		3	○	3,0	30	55		3	○	4,3	42	60		
	4v	○	3,8	38	70		4v	○	4,3	30	70		4v	○	6,8	42	70		
	5v	○	4,5	38	75		5v	○	5,1	32	75		5v	○	8,4	48	75		
	6v	○	5,2	38	124		6v	○	6,0	32	124		6v	○	12,1	48	85		
160	1	○	1,5	28	41	170	1	×	2,9	42	43	160	1	×	2,5	38	43		
	2	○	2,0	28	60		2	×	3,4	42	48		2	×	3,3	42	48		
	3	○	3,0	30	55		3	×	4,9	42	60		3	×	4,6	48	60		
	4v	○	4,3	30	70		4v	○	7,2	48	70		4v	○	7,0	48	70		
	5v	○	5,1	32	75		5v	○	9,4	48	75		5v	○	9,4	48	75		
	6v	○	6,0	32	124		6v	○	12,9	55	85		6v	○	12,9	55	85		
	6v	○	6,0	32	124		6v	○	13,1	48	85		6v	○	13,1	48	85		

▲ nur für Profil 17 only for section 17

▽ $d_d + 5,5$ mm

Anzahl der Rillen No. of grooves z	1	2	3	4	5	6
Kranzbreite Face width b_2 (mm)	25	44	63	86	105	124

- Vollscheibe Solid pulley
 - Bodenscheibe Plate pulley (mit oder ohne Spiegel with or without holes)
 - × Armscheibe Spoked pulley
- Nabenslage: einseitig bündig
Hub position: one side flush
Material: EN-GJL 200 – DIN EN 1561

Keilrillenscheiben für zylindrische Bohrung – Rillen nach DIN 2211 V-grooved pulleys for plain boring – grooves to ISO/BS/DIN

Profil Section SPB/17

Richtdurchmesser Datum diameter d_d (mm)	Anzahl der Rillen No. of grooves	Ausführung Type	Gewicht Weight (\approx kg)	Fertigbohrung Finished bore d_{max} (mm)	Nabenlänge Hub length (mm)	€ Stück zentriert each centered	Richtdurchmesser Datum diameter d_d (mm)	Anzahl der Rillen No. of grooves	Ausführung Type	Gewicht Weight (\approx kg)	Fertigbohrung Finished bore d_{max} (mm)	Nabenlänge Hub length (mm)	€ Stück zentriert each centered
180	1	×	3,1	38	43	auf Anfrage on request	315	1	×	6,4	48	49	auf Anfrage on request
	2	×	3,9	42	48			2	×	8,2	55	55	
	3	×	5,3	48	60			3	×	12,9	55	67	
	4 ∇	×	7,4	48	70			4 ∇	×	13,0	60	80	
	5 ∇	○	9,1	55	75			5 ∇	×	17,6	65	80	
	6 ∇	○	10,8	60	85			6 ∇	×	20,6	75	90	
190	1	×	3,2	42	43		355	1	×	7,0	48	49	
	2	×	4,2	42	48			2	×	9,7	55	55	
	3	×	5,5	42	60			3	×	13,4	55	67	
	4 ∇	×	7,7	48	70			4 ∇	×	18,3	60	80	
	5 ∇	○	9,2	50	75			5 ∇	×	18,8	65	75	
	6 ∇	○	12,0	55	85			6 ∇	×	19,8	75	90	
200	1	×	3,4	38	43		400	1 ∇	×	8,5	50	49	
	2	×	4,5	42	48			2 ∇	×	10,0	55	55	
	3	×	5,9	48	60			3 ∇	×	14,3	60	67	
	4 ∇	×	8,0	50	60			4 ∇	×	18,5	65	80	
	5 ∇	○	9,5	55	80			5 ∇	×	22,5	70	85	
	6 ∇	○	12,2	60	90			6 ∇	×	28,0	75	90	
212	1	×	3,8	42	43	450	1 ∇	×	9,9	50	55		
	2	×	4,7	42	48		2 ∇	×	10,9	55	55		
	3	×	6,2	48	60		3 ∇	×	15,1	60	67		
	4 ∇	×	7,7	50	70		4 ∇	×	20,5	65	80		
	5 ∇	×	10,3	50	80		5 ∇	×	26,0	70	80		
	6 ∇	○	13,5	55	90		6 ∇	×	28,9	75	90		
225	1	×	4,0	42	43	500	1 ∇	×	10,7	50	55		
	2	×	5,4	42	48		2 ∇	×	13,7	60	59		
	3	×	6,9	48	60		3 ∇	×	15,2	65	67		
	4 ∇	×	8,6	55	70		4 ∇	×	21,3	70	80		
	5 ∇	○	11,7	50	90		5 ∇	×	30,0	75	80		
	6 ∇	○	14,8	55	90		6 ∇	×	33,8	80	90		
250	1	×	4,2	42	43	560	2 ∇	×	15,0	60	55		
	2	×	6,1	48	55		3 ∇	×	24,2	65	67		
	3	×	8,6	55	60		4 ∇	×	26,0	70	80		
	4 ∇	×	9,8	60	70		5 ∇	×	34,4	75	80		
	5 ∇	×	13,2	65	80		6 ∇	×	39,0	80	90		
	6 ∇	×	17,0	65	90		630	2 ∇	×	20,2	60	80	
280	1	×	5,7	48	49	3 ∇		×	27,0	65	80		
	2	×	7,0	48	55	4 ∇		×	30,8	75	86		
	3	×	9,7	55	60	5 ∇		×	37,2	80	90		
	4 ∇	×	11,5	60	70	6 ∇		×	44,0	90	100		
	5 ∇	×	15,5	65	80	300		1	×	5,9	48	49	
	6 ∇	×	18,0	65	90		2	×	7,5	48	55		
1	×	5,9	48	49	3		×	10,5	55	67			
2	×	7,5	48	55	4 ∇		×	12,4	60	80			
3	×	10,5	55	67	5 ∇		×	16,5	65	80			
4 ∇	×	12,4	60	80	6 ∇		×	18,3	70	90			
5 ∇	×	16,5	65	80	$\nabla d_d + 5,5 \text{ mm}$								
6 ∇	×	18,3	70	90									

Anzahl der Rillen No. of grooves z	1	2	3	4	5	6
Kranzbreite Face width b_2 (mm)	25	44	63	86	105	124

- Vollscheibe Solid pulley
 - Bodenscheibe Plate pulley (mit oder ohne Spiegel with or without holes)
 - × Armscheibe Spoked pulley
- Nabenlage: einseitig bündig
Hub position: one side flush
Material: EN-GJL 200 – DIN EN 1561

Keilrillenscheiben für zylindrische Bohrung – Rillen nach DIN 2211 V-grooved pulleys for plain boring – grooves to ISO/BS/DIN

Profil Section SPC/22

Richtdurchmesser Datum diameter d_a (mm)	Anzahl der Rillen No. of grooves	Ausführung Type	Gewicht Weight (\approx kg)	Fertigbohrung Finished bore d_{max} (mm)	Nabenlänge Hub length (mm)	€ Stück zentriert each centered
180	1	○	4,2	40	54	auf Anfrage on request
	2	○	7,2	50	64	
	3	○	10,4	55	90	
	4	○	10,5	55	95	
	5	○	18,0	60	100	
	6	○	23,6	65	115	
200	1	○	4,8	40	54	
	2	○	7,8	50	64	
	3	○	8,8	55	90	
	4	○	11,2	60	95	
	5	○	15,4	65	100	
	6	○	27,0	70	125	
225	1	×	5,5	48	54	
	2	×	7,8	52	64	
	3	×	10,6	52	90	
	4	×	13,1	55	95	
	5	×	16,7	60	100	
	6	×	35,0	60	115	
250	1	×	7,3	52	54	
	2	×	8,8	52	64	
	3	×	11,0	65	90	
	4	×	15,3	70	95	
	5	×	19,0	75	100	
	6	×	23,7	60	115	
280	1	×	8,7	52	54	
	2	×	10,9	55	64	
	3	×	15,6	70	90	
	4	×	17,5	75	95	
	5	×	20,5	75	100	
315	1	×	9,1	52	54	
	2	×	13,0	55	74	
	3	×	17,1	70	90	
	4	×	20,0	75	95	
	5	×	24,7	80	100	
	6	×	31,2	85	115	
335	2	×	14,0	55	74	
	3	×	18,3	55	90	
	4	×	22,4	60	95	
	5	×	28,3	65	100	
	6	×	34,4	75	115	
	355	2	×	15,2	60	74
3		×	19,2	70	90	
4		×	25,8	70	95	
5		×	32,0	75	100	
6		×	36,2	75	115	

Richtdurchmesser Datum diameter d_a (mm)	Anzahl der Rillen No. of grooves	Ausführung Type	Gewicht Weight (\approx kg)	Fertigbohrung Finished bore d_{max} (mm)	Nabenlänge Hub length (mm)	€ Stück zentriert each centered
400	3	×	20,6	70	90	auf Anfrage on request
	4	×	28,0	70	105	
	5	×	32,0	75	100	
450	2	×	21,1	70	80	
	3	×	26,3	75	90	
	4	×	31,1	75	105	
	5	×	42,2	80	110	
500	6	×	48,5	80	120	
	3	×	28,4	75	90	
	4	×	34,1	75	105	
	5	×	48,2	80	110	
560	6	×	52,5	80	120	
	3	×	31,1	75	90	
	4	×	39,0	75	105	
	5	×	54,1	80	110	
630	6	×	61,5	85	120	
	3	×	38,5	80	90	
	4	×	48,1	80	105	
	5	×	62,2	85	110	
	6	×	73,2	85	120	

20

Anzahl der Rillen No. of grooves z	1	2	3	4	5	6
Kranzbreite Face width b_2 (mm)	38	64	90	116	142	168

- Vollscheibe Solid pulley
 - Bodenscheibe Plate pulley (mit oder ohne Spiegel with or without holes)
 - × Armscheibe Spoked pulley
- Nabenlage: einseitig bündig
Hub position: one side flush
Material: EN-GJL 200 – DIN EN 1561

Regelscheiben Variable speed pulleys

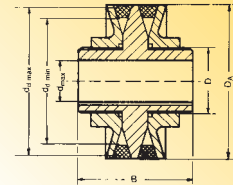
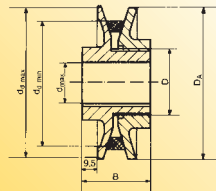

Regelscheiben für zylindrische Bohrung *Variable speed pulleys for plain boring* Material: GG

Bezeichnung Part number	D _A (mm)	D (mm)	Fertig- bohrung Finished bore d _{max} (mm)	B (mm)	Profil Section	d _{d min} (mm)	d _{d max} (mm)	Regel- faktor Variance factor	Gewicht Weight (≈ kg)	€ Stück zentriert each centered
R 083-1	83	40	26	48	SPZ	63	79	1,25	0,90	auf Anfrage on request
R 093-1	93	45	28	48	Z/10	57	77	1,35	1,03	
					SPA	66	87	1,32		
					Z/10	61	87	1,43		
R 108-1	108	50	28	48	A/13	60	85	1,42	1,65	
					SPZ	79	94	1,19		
					SPA	81	102	1,26		
R 121-1	121	55	28	48	Z/10	73	93	1,27	1,75	
					A/13	75	100	1,33		
					SPZ	92	107	1,16		
R 121-1	121	55	28	48	SPA	94	115	1,22	1,75	
					Z/10	86	106	1,23		
					A/13	88	113	1,28		
R 138-1	138	55	38	48	SPZ	109	124	1,14	2,60	
					SPA	111	132	1,19		
					SPB	116	131	1,13		
					Z/10	103	123	1,19		
					A/13	105	130	1,24		
					B/17	109	128	1,17		
R 160-1	160	80	52	48	SPZ	119	134	1,13	4,50	
					SPA	121	143	1,18		
					SPB	126	153	1,21		
					Z/10	113	133	1,18		
					A/13	115	141	1,23		
					B/17	119	150	1,26		
R 180-1	180	80	52	48	SPA	141	163	1,16	5,40	
					SPB	146	173	1,18		
					A/13	135	161	1,19		
					B/17	139	170	1,22		

Regelscheiben Variable speed pulleys

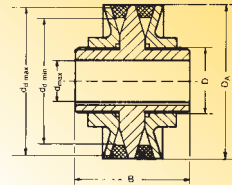
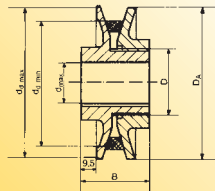

Regelscheiben für zylindrische Bohrung *Variable speed pulleys for plain boring* Material: GG

Bezeichnung Part number	D _A (mm)	D (mm)	Fertig- bohrung Finished bore d _{d max} (mm)	B (mm)	Profil Section	d _{d min} (mm)	d _{d max} (mm)	Regel- faktor Variance factor	Gewicht Weight (≈ kg)	€ Stück zentriert each centered
R 083-2	83	40	26	76	SPZ Z/10	63 57	79 77	1,25 1,35	1,50	auf Anfrage on request
R 093-2	93	45	28	76	SPZ	67	89	1,33	1,75	
					SPA	66	87	1,32		
					Z/10	61	87	1,43		
R 108-2	108	50	28	76	A/13	60	85	1,42	2,15	
					SPZ	79	94	1,19		
					SPA	81	102	1,26		
R 121-2	121	55	28	76	Z/10	73	93	1,27	2,70	
					A/13	75	100	1,33		
					SPZ	92	107	1,16		
R 121-2	121	55	28	76	SPA	94	115	1,22	2,70	
					Z/10	86	106	1,23		
					A/13	88	113	1,28		
R 138-2	138	55	38	76	SPZ	109	124	1,14	4,50	
					SPA	111	132	1,19		
					SPB	116	131	1,13		
					Z/10	103	123	1,19		
					A/13	105	130	1,24		
R 160-2	160	80	52	90	B/17	109	128	1,17	7,50	
					SPZ	119	134	1,13		
					SPA	121	143	1,18		
					SPB	126	153	1,21		
					Z/10	113	133	1,18		
R 180-2	180	80	52	90	A/13	115	141	1,23	9,20	
					B/17	119	150	1,26		
					SPA	141	163	1,16		
					SPB	146	173	1,18		
R 180-2	180	80	52	90	A/13	135	161	1,19	9,20	
					B/17	139	170	1,22		
					SPB	146	173	1,18		

GG = Grauguss Cast iron Fertigungstechnische Änderungen vorbehalten. We reserve the right to make technical changes.

Regelscheiben Variable speed pulleys

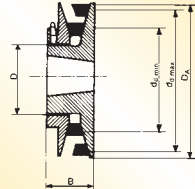

Regelscheiben für Taperbuchsen *Variable speed pulleys for taper bushes* Material: GG

Bezeichnung Part number	D _A (mm)	D (mm)	Fertig- bohrung Finished bore d _{d max} (mm)	B (mm)	Profil Section	d _{d min} (mm)	d _{d max} (mm)	Regel- faktor Variance factor	Gewicht ohne Buchse Weight without bush (= kg)	Taper- Buchse Taper bush	€ Stück ohne Buchse each without bush
TB-R 092-1	92	46	25	31	SPZ	60	89	1,48	0,85	1008	auf Anfrage on request
TB-R 108-1	108	50	28	35	Z/10	55	88	1,60	1,20	1108	
					SPA	76	102	1,34			
					Z/10	68	92	1,35			
					A/13	70	100	1,43			
TB-R 120-1	120	55	28	35	B/17	87	97	1,11			
					SPZ	87	105	1,20			
					SPA	88	114	1,29			
					Z/10	80	104	1,30			
TB-R 138-1	138	65	32	38	A/13	82	112	1,36			
					B/17	98	108	1,10			
					SPZ	105	123	1,17			
					SPA	106	132	1,24			
TB-R 159-1	159	75	42	39	Z/10	98	122	1,24			
					A/13	100	130	1,30			
					B/17	116	126	1,09			
					SPZ	126	144	1,14			
TB-R 180-1	180	75	42	45	SPA	128	154	1,20			
					Z/10	122	152	1,24			
					A/13	128	152	1,18			
					B/17	125	148	1,18			
					SPZ	133	151	1,14			
					SPA	134	160	1,19			
					SPB	137	173	1,26			
					Z/10	128	151	1,17			
A/13	128	158	1,23								
B/17	132	170	1,29								

Taperbuchse <i>Taper bush</i>	1008	1108	1215	1615
Bohrung d ₂ (mm) von ... bis ... Bore d ₂ (mm) from ... to ...	10-25	10-28	11-32	14-42
€/Stück each	auf Anfrage / on request			

GG = Grauguss Cast iron
Fertigungstechnische Änderungen vorbehalten.
We reserve the right to make technical changes.

Bohrungsdurchmesser d₂ siehe Seite 3-4.
Bore diameters d₂ see page 3-4.

Keilrippenscheiben für Taperbuchsen, Profil PJ

Ribbed belt pulleys for taper bushes, section PJ

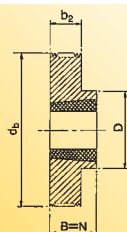

Ausf. Type 1

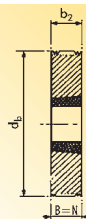

Ausf. Type 4

Bezeichnung Part number	Anzahl der Rillen No. of ribs	Aus- führung Type	Material	d _b (mm)	b ₂ (mm)	B (mm)	N (mm)	D (mm)	Taper- Buchse Taper bush	€ Stück ohne Buchse each without bush
TB 4 PJ 47,5	4	1	GG	47,5	13	23	23	47,5	1008	
TB 4 PJ 52,5	4	1	GG	52,5	13	23	23	47,5	1008	
TB 4 PJ 57,5	4	1	GG	57,5	13	23	23	54,0	1108	
TB 4 PJ 62,5	4	1	GG	62,5	13	23	23	54,0	1108	
TB 4 PJ 67,5	4	1	GG	67,5	13	23	23	54,0	1108	
TB 4 PJ 72,5	4	1	GG	72,5	13	23	23	54,0	1108	
TB 4 PJ 77,5	4	1	GG	77,5	13	26	26	70,0	1210	
TB 4 PJ 82,5	4	1	GG	82,5	13	26	26	78,0	1210	
TB 4 PJ 87,5	4	1	GG	87,5	13	26	26	78,0	1210	
TB 4 PJ 92,5	4	1	GG	92,5	13	26	26	78,0	1210	
TB 4 PJ 97,5	4	1	GG	97,5	13	26	26	78,0	1210	
TB 4 PJ 102,5	4	1	GG	102,5	13	26	26	85,0	1610	
TB 4 PJ 107,5	4	1	GG	107,5	13	26	26	85,0	1610	
TB 4 PJ 112,5	4	1	GG	112,5	13	26	26	85,0	1610	
TB 4 PJ 117,5	4	1	GG	117,5	13	26	26	85,0	1610	
TB 4 PJ 122,5	4	1	GG	122,5	13	26	26	85,0	1610	
TB 4 PJ 127,5	4	1	GG	127,5	13	26	26	85,0	1610	
TB 4 PJ 137,5	4	1	GG	137,5	13	26	26	85,0	1610	
TB 4 PJ 152,5	4	1	GG	152,5	13	26	26	85,0	1610	
TB 4 PJ 162,5	4	1	GG	162,5	13	26	26	85,0	1610	
TB 4 PJ 172,5	4	1	GG	172,5	13	26	26	85,0	1610	
TB 4 PJ 182,5	4	1	GG	182,5	13	26	26	85,0	1610	
TB 4 PJ 192,5	4	1	GG	192,5	13	26	26	85,0	1610	
TB 4 PJ 202,5	4	1	GG	202,5	13	33	33	100,0	2012	
TB 4 PJ 222,5	4	1	GG	222,5	13	33	33	100,0	2012	
TB 8 PJ 47,5	8	4	GG	47,5	23	23	23	—	1008	auf Anfrage on request
TB 8 PJ 52,5	8	4	GG	52,5	23	23	23	—	1008	
TB 8 PJ 57,5	8	4	GG	57,5	23	23	23	—	1108	
TB 8 PJ 62,5	8	4	GG	62,5	23	23	23	—	1108	
TB 8 PJ 67,5	8	4	GG	67,5	23	23	23	—	1108	
TB 8 PJ 72,5	8	4	GG	72,5	23	23	23	—	1108	
TB 8 PJ 77,5	8	1	GG	77,5	23	26	26	70,0	1210	
TB 8 PJ 82,5	8	1	GG	82,5	23	26	26	78,0	1210	
TB 8 PJ 87,5	8	1	GG	87,5	23	26	26	78,0	1210	
TB 8 PJ 92,5	8	1	GG	92,5	23	26	26	78,0	1210	
TB 8 PJ 97,5	8	1	GG	97,5	23	26	26	78,0	1210	
TB 8 PJ 102,5	8	1	GG	102,5	23	26	26	85,0	1610	
TB 8 PJ 107,5	8	1	GG	107,5	23	26	26	85,0	1610	
TB 8 PJ 112,5	8	1	GG	112,5	23	26	26	85,0	1610	
TB 8 PJ 117,5	8	1	GG	117,5	23	26	26	85,0	1610	
TB 8 PJ 122,5	8	1	GG	122,5	23	26	26	85,0	1610	
TB 8 PJ 127,5	8	1	GG	127,5	23	26	26	85,0	1610	
TB 8 PJ 137,5	8	1	GG	137,5	23	26	26	85,0	1610	
TB 8 PJ 152,5	8	1	GG	152,5	23	26	26	85,0	1610	
TB 8 PJ 162,5	8	1	GG	162,5	23	26	26	85,0	1610	
TB 8 PJ 172,5	8	1	GG	172,5	23	26	26	85,0	1610	
TB 8 PJ 182,5	8	1	GG	182,5	23	26	26	85,0	1610	
TB 8 PJ 192,5	8	1	GG	192,5	23	26	26	85,0	1610	
TB 8 PJ 202,5	8	1	GG	202,5	23	33	33	100,0	2012	
TB 8 PJ 222,5	8	1	GG	222,5	23	33	33	100,0	2012	

Taperbuchse Taper bush	1008	1108	1210	1610	2012
Bohrung d ₂ (mm) von ... bis ... Bore d ₂ (mm) from ... to ...	10-25	10-28	11-32	14-42	14-50
€/Stück each	auf Anfrage / on request				

GG = Grauguss Cast iron
 Weitere Abmessungen auf Anfrage.
 Further sizes on request.
 Fertigungstechnische Änderungen vorbehalten.
 We reserve the right to make technical changes.
 Bohrungsdurchmesser d₂ siehe Seite 3-4.
 Bore diameters d₂ see page 3-4.

Keilrippenscheiben für Taperbuchsen, Profil PJ Ribbed belt pulleys for taper bushes, section PJ

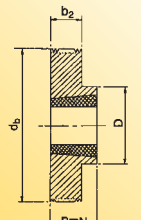

Ausf. Type 1

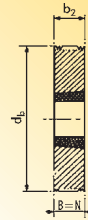

Ausf. Type 4

Bezeichnung Part number	Anzahl der Rillen No. of ribs	Aus- führung Type	Material	d _b (mm)	b ₂ (mm)	B (mm)	N (mm)	D (mm)	Taper- Buchse Taper bush	€ Stück ohne Buchse each without bush
TB 12 PJ 62,5	12	2	GG	62,5	32	32	23	50,0	1108	auf Anfrage on request
TB 12 PJ 67,5	12	2	GG	67,5	32	32	23	50,0	1108	
TB 12 PJ 72,5	12	2	GG	72,5	32	32	23	50,0	1108	
TB 12 PJ 77,5	12	2	GG	77,5	32	32	26	62,0	1210	
TB 12 PJ 82,5	12	2	GG	82,5	32	32	26	62,0	1210	
TB 12 PJ 87,5	12	2	GG	87,5	32	32	26	70,0	1610	
TB 12 PJ 92,5	12	2	GG	92,5	32	32	26	70,0	1610	
TB 12 PJ 97,5	12	2	GG	97,5	32	32	26	70,0	1610	
TB 12 PJ 102,5	12	2	GG	102,5	32	32	26	70,0	1610	
TB 12 PJ 107,5	12	2	GG	107,5	32	32	26	70,0	1610	
TB 12 PJ 112,5	12	2	GG	112,5	32	32	26	70,0	1610	
TB 12 PJ 117,5	12	2	GG	117,5	32	32	26	70,0	1610	
TB 12 PJ 122,5	12	2	GG	122,5	32	32	26	70,0	1610	
TB 12 PJ 127,5	12	1	GG	127,5	32	32	33	100,0	2012	
TB 12 PJ 137,5	12	1	GG	137,5	32	32	33	100,0	2012	
TB 12 PJ 152,5	12	1	GG	152,5	32	32	33	100,0	2012	
TB 12 PJ 162,5	12	1	GG	162,5	32	32	33	100,0	2012	
TB 12 PJ 172,5	12	1	GG	172,5	32	32	33	100,0	2012	
TB 12 PJ 182,5	12	1	GG	182,5	32	46	46	110,0	2517	
TB 12 PJ 192,5	12	1	GG	192,5	32	46	46	110,0	2517	
TB 12 PJ 202,5	12	1	GG	202,5	32	46	46	110,0	2517	
TB 12 PJ 222,5	12	1	GG	222,5	32	46	46	110,0	2517	
TB 16 PJ 62,5	16	2	GG	62,5	41	41	23	50,0	1108	
TB 16 PJ 67,5	16	2	GG	67,5	41	41	23	50,0	1108	
TB 16 PJ 72,5	16	2	GG	72,5	41	41	26	62,0	1210	
TB 16 PJ 77,5	16	2	GG	77,5	41	41	26	62,0	1210	
TB 16 PJ 82,5	16	2	GG	82,5	41	41	26	62,0	1210	
TB 16 PJ 87,5	16	2	GG	87,5	41	41	26	70,0	1610	
TB 16 PJ 92,5	16	2	GG	92,5	41	41	26	70,0	1610	
TB 16 PJ 97,5	16	2	GG	97,5	41	41	26	70,0	1610	
TB 16 PJ 102,5	16	2	GG	102,5	41	41	26	70,0	1610	
TB 16 PJ 107,5	16	2	GG	107,5	41	41	26	70,0	1610	
TB 16 PJ 112,5	16	2	GG	112,5	41	41	33	85,0	2012	
TB 16 PJ 117,5	16	2	GG	117,5	41	41	33	85,0	2012	
TB 16 PJ 122,5	16	2	GG	122,5	41	41	33	85,0	2012	
TB 16 PJ 127,5	16	2	GG	127,5	41	41	33	85,0	2012	
TB 16 PJ 137,5	16	2	GG	137,5	41	41	33	85,0	2012	
TB 16 PJ 152,5	16	2	GG	152,5	41	41	33	85,0	2012	
TB 16 PJ 162,5	16	2	GG	162,5	41	41	33	85,0	2012	
TB 16 PJ 172,5	16	2	GG	172,5	41	41	33	85,0	2012	
TB 16 PJ 182,5	16	1	GG	182,5	41	46	46	110,0	2517	
TB 16 PJ 192,5	16	1	GG	192,5	41	46	46	110,0	2517	
TB 16 PJ 202,5	16	1	GG	202,5	41	46	46	110,0	2517	
TB 16 PJ 222,5	16	1	GG	222,5	41	46	46	110,0	2517	

Taperbuchse Taper bush	1108	1210	1610	2012	2517
Bohrung d ₂ (mm) von ... bis ... Bore d ₂ (mm) from ... to ...	10-28	11-32	14-42	14-50	16-60
€/Stück each	auf Anfrage / on request				

GG = Grauguss Cast iron
 Weitere Abmessungen auf Anfrage.
 Further sizes on request.
 Fertigungstechnische Änderungen vorbehalten.
 We reserve the right to make technical changes.
 Bohrungsdurchmesser d₂ siehe Seite 3-4.
 Bore diameters d₂ see page 3-4.

Keilrippenscheiben für Taperbuchsen, Profil PL Ribbed belt pulleys for taper bushes, section PL

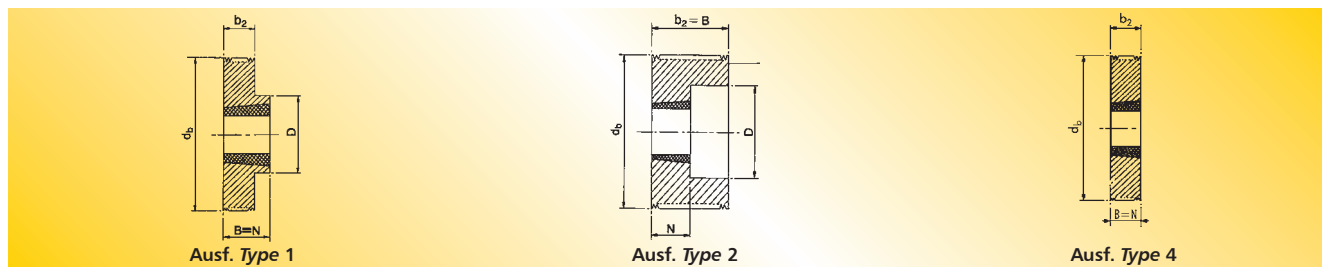

Bezeichnung Part number	Anzahl der Rillen No. of ribs	Aus- führung Type	Material	d _b (mm)	b ₂ (mm)	B (mm)	N (mm)	D (mm)	Taper- Buchse Taper bush	€ Stück ohne Buchse each without bush
TB 6 PL 78	6	2	GG	78	33	33	26	62,0	1210	auf Anfrage on request
TB 6 PL 83	6	2	GG	83	33	33	26	62,0	1210	
TB 6 PL 88	6	2	GG	88	33	33	26	70,0	1610	
TB 6 PL 93	6	2	GG	93	33	33	26	70,0	1610	
TB 6 PL 98	6	2	GG	98	33	33	26	70,0	1610	
TB 6 PL 103	6	2	GG	103	33	33	26	70,0	1610	
TB 6 PL 108	6	2	GG	108	33	33	26	70,0	1610	
TB 6 PL 113	6	2	GG	113	33	33	26	70,0	1610	
TB 6 PL 118	6	2	GG	118	33	33	26	70,0	1610	
TB 6 PL 123	6	4	GG	123	33	33	33	—	2012	
TB 6 PL 133	6	4	GG	133	33	33	33	—	2012	
TB 6 PL 148	6	4	GG	148	33	33	33	—	2012	
TB 6 PL 158	6	4	GG	158	33	33	33	—	2012	
TB 6 PL 168	6	4	GG	168	33	33	33	—	2012	
TB 6 PL 178	6	1	GG	178	33	46	46	110,0	2517	
TB 6 PL 188	6	1	GG	188	33	46	46	110,0	2517	
TB 6 PL 198	6	1	GG	198	33	46	46	110,0	2517	
TB 6 PL 218	6	1	GG	218	33	46	46	110,0	2517	
TB 6 PL 238	6	1	GG	238	33	46	46	110,0	2517	
TB 6 PL 258	6	1	GG	258	33	46	46	110,0	2517	
TB 6 PL 278	6	1	GG	278	33	46	46	110,0	2517	
TB 6 PL 298	6	1	GG	298	33	46	46	110,0	2517	
TB 6 PL 318	6	1	GG	318	33	46	46	110,0	2517	
TB 6 PL 348	6	1	GG	348	33	46	46	110,0	2517	
TB 6 PL 388	6	1	GG	388	33	46	46	110,0	2517	
TB 8 PL 78	8	2	GG	78	42	42	26	62,0	1210	
TB 8 PL 83	8	2	GG	83	42	42	26	62,0	1210	
TB 8 PL 88	8	2	GG	88	42	42	26	70,0	1610	
TB 8 PL 93	8	2	GG	93	42	42	26	70,0	1610	
TB 8 PL 98	8	2	GG	98	42	42	26	70,0	1610	
TB 8 PL 103	8	2	GG	103	42	42	33	85,0	2012	
TB 8 PL 108	8	2	GG	108	42	42	33	85,0	2012	
TB 8 PL 113	8	2	GG	113	42	42	33	85,0	2012	
TB 8 PL 118	8	2	GG	118	42	42	33	85,0	2012	
TB 8 PL 123	8	2	GG	123	42	42	33	85,0	2012	
TB 8 PL 133	8	2	GG	133	42	42	33	85,0	2012	
TB 8 PL 148	8	2	GG	148	42	42	33	85,0	2012	
TB 8 PL 158	8	2	GG	158	42	42	33	85,0	2012	
TB 8 PL 168	8	2	GG	168	42	42	33	85,0	2012	
TB 8 PL 178	8	1	GG	178	42	46	46	110,0	2517	
TB 8 PL 188	8	1	GG	188	42	46	46	110,0	2517	
TB 8 PL 198	8	1	GG	198	42	46	46	110,0	2517	
TB 8 PL 218	8	1	GG	218	42	46	46	110,0	2517	
TB 8 PL 238	8	1	GG	238	42	46	46	110,0	2517	
TB 8 PL 258	8	1	GG	258	42	46	46	110,0	2517	
TB 8 PL 278	8	1	GG	278	42	46	46	110,0	2517	
TB 8 PL 298	8	1	GG	298	42	46	46	110,0	2517	
TB 8 PL 318	8	1	GG	318	42	46	46	110,0	2517	
TB 8 PL 348	8	1	GG	348	42	46	46	110,0	2517	
TB 8 PL 388	8	1	GG	388	42	46	46	110,0	2517	

Taperbuchse Taper bush	1210	1610	2012	2517
Bohrung d ₂ (mm) von ... bis ... Bore d ₂ (mm) from ... to ...	11-32	14-42	14-50	16-60
€/Stück each	auf Anfrage / on request			

GG = Grauguss Cast iron
Weitere Abmessungen auf Anfrage.
Further sizes on request.
Fertigungstechnische Änderungen vorbehalten.
We reserve the right to make technical changes.
Bohrungsdurchmesser d₂ siehe Seite 3-4.
Bore diameters d₂ see page 3-4.

Keilrippenscheiben für Taperbuchsen, Profil PL Ribbed belt pulleys for taper bushes, section PL

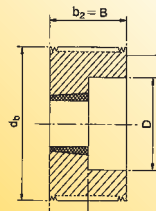

Ausf. Type 2

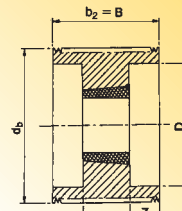

Ausf. Type 3

Bezeichnung Part number	Anzahl der Rillen No. of ribs	Aus- führung Type	Material	d _b (mm)	b ₂ (mm)	B (mm)	N (mm)	D (mm)	Taper- Buchse Taper bush	€ Stück ohne Buchse each without bush
TB 10 PL 88	10	3	GG	88	53	53	26	70,0	1610	auf Anfrage on request
TB 10 PL 93	10	3	GG	93	53	53	26	70,0	1610	
TB 10 PL 98	10	3	GG	98	53	53	26	70,0	1610	
TB 10 PL 103	10	2	GG	103	53	53	33	85,0	2012	
TB 10 PL 108	10	2	GG	108	53	53	33	85,0	2012	
TB 10 PL 118	10	2	GG	118	53	53	33	85,0	2012	
TB 10 PL 123	10	2	GG	123	53	53	33	85,0	2012	
TB 10 PL 133	10	2	GG	133	53	53	33	85,0	2012	
TB 10 PL 148	10	2	GG	148	53	53	33	85,0	2012	
TB 10 PL 158	10	2	GG	158	53	53	33	85,0	2012	
TB 10 PL 168	10	2	GG	168	53	53	33	85,0	2012	
TB 10 PL 178	10	2	GG	178	53	53	46	105,0	2517	
TB 10 PL 188	10	2	GG	188	53	53	46	105,0	2517	
TB 10 PL 198	10	2	GG	198	53	53	46	105,0	2517	
TB 10 PL 218	10	2	GG	218	53	53	46	105,0	2517	
TB 10 PL 238	10	2	GG	238	53	53	46	105,0	2517	
TB 10 PL 258	10	2	GG	258	53	53	46	105,0	2517	
TB 10 PL 278	10	2	GG	278	53	53	46	105,0	2517	
TB 10 PL 298	10	2	GG	298	53	53	46	105,0	2517	
TB 10 PL 318	10	2	GG	318	53	53	46	105,0	2517	
TB 10 PL 348	10	2	GG	348	53	53	46	105,0	2517	
TB 10 PL 388	10	2	GG	388	53	53	46	105,0	2517	
TB 12 PL 88	12	3	GG	88	62	62	26	70,0	1610	
TB 12 PL 93	12	3	GG	93	62	62	26	70,0	1610	
TB 12 PL 98	12	3	GG	98	62	62	26	70,0	1610	
TB 12 PL 103	12	3	GG	103	62	62	33	85,0	2012	
TB 12 PL 108	12	3	GG	108	62	62	33	85,0	2012	
TB 12 PL 113	12	3	GG	113	62	62	33	85,0	2012	
TB 12 PL 118	12	3	GG	118	62	62	33	85,0	2012	
TB 12 PL 123	12	3	GG	123	62	62	33	85,0	2012	
TB 12 PL 133	12	3	GG	133	62	62	33	85,0	2012	
TB 12 PL 148	12	2	GG	148	62	62	46	105,0	2517	
TB 12 PL 158	12	2	GG	158	62	62	46	105,0	2517	
TB 12 PL 168	12	2	GG	168	62	62	46	105,0	2517	
TB 12 PL 178	12	2	GG	178	62	62	46	105,0	2517	
TB 12 PL 188	12	2	GG	188	62	62	46	105,0	2517	
TB 12 PL 198	12	2	GG	198	62	62	46	105,0	2517	
TB 12 PL 218	12	2	GG	218	62	62	46	105,0	2517	
TB 12 PL 238	12	2	GG	238	62	62	52	130,0	3020	
TB 12 PL 258	12	2	GG	258	62	62	52	130,0	3020	
TB 12 PL 278	12	2	GG	278	62	62	52	130,0	3020	
TB 12 PL 298	12	2	GG	298	62	62	52	130,0	3020	
TB 12 PL 318	12	2	GG	318	62	62	52	130,0	3020	
TB 12 PL 348	12	2	GG	348	62	62	52	130,0	3020	
TB 12 PL 388	12	2	GG	388	62	62	52	130,0	3020	

Taperbuchse Taper bush	1610	2012	2517	3020
Bohrung d ₂ (mm) von ... bis ... Bore d ₂ (mm) from ... to ...	14-42	14-50	16-60	25-75
€/Stück each	auf Anfrage / on request			

GG = Grauguss Cast iron
 Weitere Abmessungen auf Anfrage.
 Further sizes on request.
 Fertigungstechnische Änderungen vorbehalten.
 We reserve the right to make technical changes.
 Bohrungsdurchmesser d₂ siehe Seite 3-4.
 Bore diameters d₂ see page 3-4.

Keilrippenscheiben für Taperbuchsen, Profil PL Ribbed belt pulleys for taper bushes, section PL

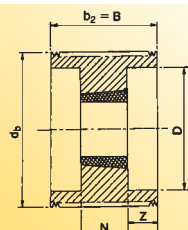

Ausf. Type 3

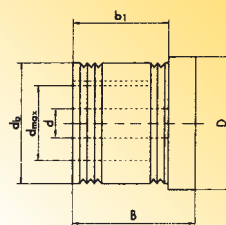

Ausf. Type VB (für zyl. Bohrung for plain boring)

Bezeichnung Part number	Anzahl der Rillen No. of ribs	Ausführung Type	Material	d _b (mm)	b ₂ (mm)	B (mm)	N (mm)	D (mm)	Taper-Buchse Taper bush	€ Stück ohne Buchse each without bush
TB 16 PL 103	16	3	GG	103	80	80	33	85,0	2012	auf Anfrage on request
TB 16 PL 108	16	3	GG	108	80	80	33	85,0	2012	
TB 16 PL 113	16	3	GG	113	80	80	33	85,0	2012	
TB 16 PL 118	16	3	GG	118	80	80	33	85,0	2012	
TB 16 PL 123	16	3	GG	123	80	80	33	85,0	2012	
TB 16 PL 133	16	3	GG	133	80	80	33	85,0	2012	
TB 16 PL 148	16	3	GG	148	80	80	46	105,0	2517	
TB 16 PL 158	16	3	GG	158	80	80	46	105,0	2517	
TB 16 PL 168	16	3	GG	168	80	80	46	105,0	2517	
TB 16 PL 178	16	3	GG	178	80	80	46	105,0	2517	
TB 16 PL 188	16	3	GG	188	80	80	46	105,0	2517	
TB 16 PL 198	16	3	GG	198	80	80	46	105,0	2517	
TB 16 PL 218	16	3	GG	218	80	80	46	105,0	2517	
TB 16 PL 238	16	3	GG	238	80	80	52	130,0	3020	
TB 16 PL 258	16	3	GG	258	80	80	52	130,0	3020	
TB 16 PL 278	16	3	GG	278	80	80	52	130,0	3020	
TB 16 PL 298	16	3	GG	298	80	80	52	130,0	3020	
TB 16 PL 318	16	3	GG	318	80	80	52	130,0	3020	
TB 16 PL 348	16	3	GG	348	80	80	52	130,0	3020	
TB 16 PL 388	16	3	GG	388	80	80	52	130,0	3020	

Taperbuchse Taper bush	2012	2517	3020
Bohrung d ₂ (mm) von ... bis ... Bore d ₂ (mm) from ... to ...	14-50	16-60	25-75
€/Stück each	auf Anfrage / on request		

Bohrungsdurchmesser d₂ siehe Seite 3-4.
Bore diameters d₂ see page 3-4.

Keilrippenscheiben mit zylindrischer Bohrung, Profil PJ Ribbed belt pulleys for plain boring, section PJ

Bezeichnung Part number	Anzahl der Rillen No. of ribs	Ausführung Type	Material	d _b (mm)	b ₁ (mm)	B (mm)	D (mm)	Vorbohrung Pilot bore d (mm)	Fertigbohrung Finished bore d _{max} (mm)	Gewicht Weight (= kg)	€ Stück each
4 PJ 22,5	4	VB	GG	22,5	13	20	25	8	12,0	0,045	auf Anfrage on request
4 PJ 27,5	4	VB	GG	27,5	13	20	30	8	14,0	0,070	
4 PJ 32,5	4	VB	GG	32,5	13	20	35	8	18,0	0,100	
4 PJ 37,5	4	VB	GG	37,5	13	20	40	8	20,0	0,135	
4 PJ 42,5	4	VB	GG	42,5	13	20	45	8	22,0	0,180	
8 PJ 22,5	8	VB	GG	22,5	23	30	25	8	12,0	0,063	
8 PJ 27,5	8	VB	GG	27,5	23	30	30	8	14,0	0,100	
8 PJ 32,5	8	VB	GG	32,5	23	30	35	8	18,0	0,150	
8 PJ 37,5	8	VB	GG	37,5	23	30	40	8	20,0	0,200	
8 PJ 42,5	8	VB	GG	42,5	23	30	45	8	22,0	0,265	
12 PJ 22,5	12	VB	GG	22,5	32	40	25	8	12,0	0,086	
12 PJ 27,5	12	VB	GG	27,5	32	40	30	8	14,0	0,140	
12 PJ 32,5	12	VB	GG	32,5	32	40	35	8	18,0	0,200	
12 PJ 37,5	12	VB	GG	37,5	32	40	40	8	20,0	0,280	
12 PJ 42,5	12	VB	GG	42,5	32	40	45	8	22,0	0,360	

GG = Grauguss Cast iron

Weitere Abmessungen auf Anfrage. Further sizes on request. Fertigungstechnische Änderungen vorbehalten. We reserve the right to make technical changes.

Flachriemenscheiben für Taperbuchsen Flat belt pulleys for taper bushes

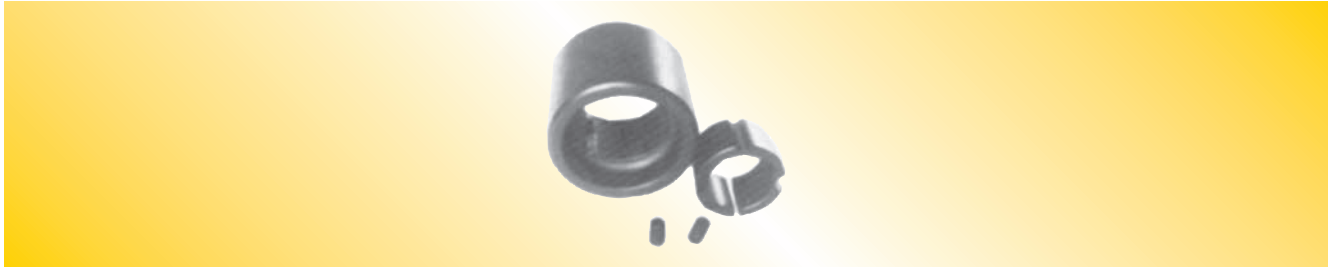

Außendurchmesser x Breite Outside diameter x width (mm)	Taperbuchse Taper bush	€ Stück ohne Buchse each without bush	Außendurchmesser x Breite Outside diameter x width (mm)	Taperbuchse Taper bush	€ Stück ohne Buchse each without bush
63 x 50	1108	auf Anfrage on request	224 x 50	2517	auf Anfrage on request
80 x 50	1210		224 x 80	2517	
80 x 80	1615		224 x 100	3020	
90 x 50	1615		224 x 125	3030	
90 x 80	1615		224 x 160	3030	
90 x 100	1615		250 x 80	2517	
100 x 50	1615		250 x 100	3020	
100 x 80	1615		250 x 125	3030	
100 x 100	1615		250 x 160	3030	
125 x 50	2012		280 x 100	3020	
125 x 80	2517		280 x 125	3030	
125 x 100	2517		280 x 160	3535	
125 x 125	2517		280 x 200	4040	
140 x 50	2012		315 x 100	3020	
140 x 80	2517		315 x 125	3030	
140 x 100	3020		315 x 160	3535	
140 x 125	3030		315 x 200	4040	
150 x 50	2012		355 x 100	3030	
150 x 80	2517		355 x 125	3030	
150 x 100	3020		355 x 160	3535	
150 x 125	3030		355 x 200	4040	
150 x 160	3030		400 x 100	3535	
160 x 50	2012		400 x 125	3535	
160 x 80	2517		400 x 160	3535	
160 x 100	3020		400 x 200	4040	
160 x 125	3030		450 x 160	3535	
160 x 160	3030		450 x 200	4040	
180 x 80	2517		500 x 160	4040	
180 x 100	3020		500 x 200	4545	
180 x 125	3030		560 x 160	4040	
180 x 160	3030	560 x 200	4545		
200 x 80	2517	630 x 160	4545		
200 x 100	3020	630 x 200	5050		
200 x 125	3030				
200 x 160	3030				

Taperbuchse Taper bush	1108	1210	1615	2012	2517	3020	3030	3535	4040	4545	5050
Bohrung d ₂ (mm) von ... bis ... Bore d ₂ (mm) from ... to ...	10-28	11-32	14-42	14-50	16-60	25-75	35-75	35-90	40-100	55-110	70-125
€/Stück each	auf Anfrage / on request										

Motorspannschienen

Motor slide rails

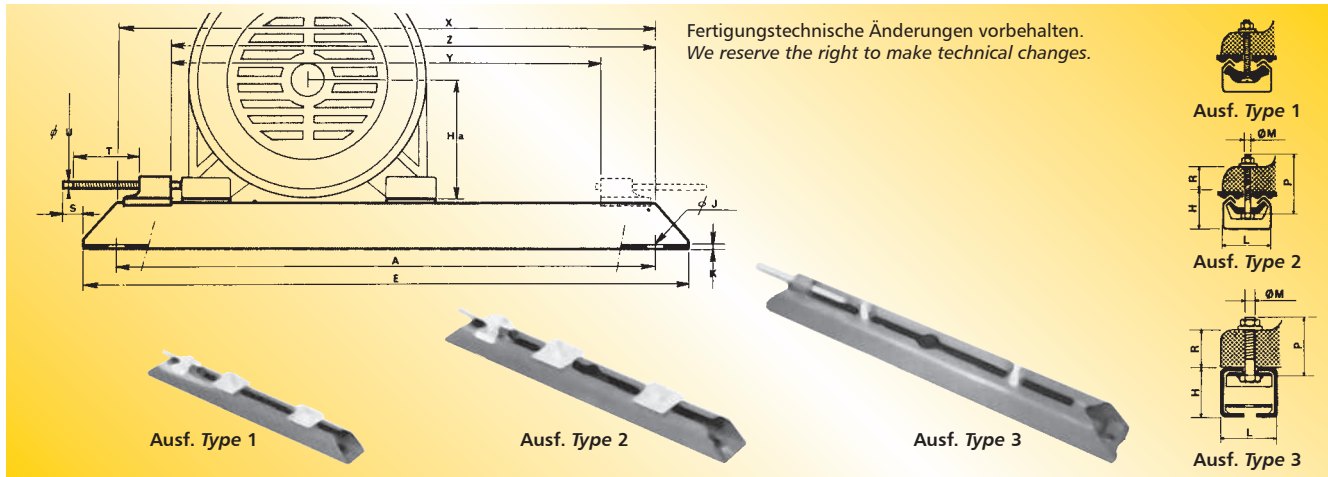

Bezeichnung Part number	S71/6VS	N300/6VS	S100/8VS	S132/10VS	N600/10VS	S180/12VS	S225/16GS	S280/20GS	S355/24GS	
Ausführung Type	1	1	2	2	2	2	3	3	3	
Motorachshöhe Motor shaft centre height Ha (mm)	56/63/71	80	80/90/100	100/112/132	160	160/180	200/225	250/280	315/355	
Abmessungen Dimensions	A (mm)	280,0	343,0	355,0	480,0	580,0	630,0	800,0	1000,0	1250,0
	E (mm)	312,0	375,0	395,0	530,0	630,0	686,0	864,0	1072,0	1330,0
	H (mm)	28,0	28,0	40,0	49,5	49,5	60,5	75,0	100,0	125,0
	Ø J (mm)	10,5	10,5	13,0	15,0	15,0	19,0	19,0	27,0	30,0
	K (mm)	1,5	1,5	2,5	7,0	7,0	7,0	8,0	10,0	13,0
	L (mm)	40,2	40,2	50,0	60,0	60,0	75,0	90,0	112,0	130,0
	Ø M (mm)	6,0	6,0	8,0	10,0	10,0	12,0	16,0	20,0	24,0
	P (mm)	35,0	35,0	45,0	55,0	55,0	70,0	70,0	80,0	100,0
	R (mm)	13,0	13,0	18,5	23,5	23,5	34,0	41,0	48,0	62,0
	S (mm)	20,0	20,0	30,0	37,0	37,0	50,0	167,0	200,0	230,0
T (mm)	75,0	75,0	97,0	119,0	119,0	154,0	300,0	360,0	430,0	
□ U (mm)	6,0	6,0	8,0	9,0	9,0	12,0	16,0	19,0	21,0	
Nutzlänge Working length	X (mm)	262,0	325,0	324,0	442,0	542,0	—	—	—	—
	Y (mm)	206,0	265,0	264,0	368,0	473,0	475,0	623,0	764,0	946,0
	Z (mm)	234,0	295,0	294,0	405,0	502,5	525,0	698,0	864,0	1064,0
Gewicht je Paar Weight per pair (≈ kg)	1,120	1,300	2,970	6,100	6,500	10,650	16,200	36,100	59,500	
€/Satz set	auf Anfrage / on request									

Vorteile der MS Motorspannschienen

- Sie sind unzerbrechlich, weil sie ganz aus Stahl hergestellt sind.
- Die genormten Motorbefestigungsschrauben sind leicht auswechselbar, z. B. bei starken Motorfüßen oder bei zu befestigenden Zusatzteilen.
- Leichtes Aufsetzen des Motors:
Nach dem Einstecken der Motorbefestigungsschrauben in die Motorfüße wird das Ganze mit den Spezialmuttern in die Stahlspannschienen eingeschoben.
- Alle Einzelteile sind bestens gegen Korrosion durch entsprechende Oberflächenbehandlung geschützt.
- Stahlspannschienen: phosphatiert und grün einbrennlackiert.
- Spannschrauben: elektro-verzinkt.
- Motorbefestigungsschrauben:
für S 71 bis S 180 elektro-verzinkt,
für S 225 bis S 355 phosphatiert und mit Rostschutz versehen.

Die mit „S“ gekennzeichneten Abmessungen (z. B. S 71) entsprechen der französischen Norm U.T.E. C-51106. Die Zahlen 71, 100, 132, 180, 225, 280 und 355 bezeichnen die maximalen Motorachshöhen in mm für den jeweiligen Spannschienen-Typ.

Die Zahlen hinter dem Schrägstrich (6, 8, 10, 12, 16, 20, 24) geben den Gewindedurchmesser der entsprechenden Befestigungsschrauben an (6 = M6).

Die Buchstaben VS bzw. GS bezeichnen die Ausführung der Spannkloben:

- VS = verschiebbarer Spannkloben
- GS = geschweißter Spannkloben

Die Typen N 300, N 400 und N 600 sind nicht genormt. Es handelt sich jeweils um die verlängerte Ausführung der genormten Schiene, sodass hierfür die gleichen Ersatzteile verwendet werden können.

Ein Satz Spannschienen besteht aus 2 Schienen inklusive aller Befestigungsteile.

Advantages of MS motor slide rails

- Rugged all steel construction.
- The standard motor fixing bolts are easily replaced, e. g. for heavier motor feet or for the mounting of auxiliary equipment.
- Easy motor mounting. After inserting the motor mounting bolts into the motor feet, the whole unit is pushed into the rails.
- All parts are fully corrosion protected.
- Steel tension rails: Phosphated and stone-enamelled in green.
- The adjusting bolts are zinc plated.
- The motor mounting bolts:
for S 71 up to S 180 are zinc plated,
for S 225 up to S 355 are phosphated and rust protected.

The sizes marked with "S" (e. g. S 71) correspond to the French standard U.T.E. C-51106.

The numbers 71, 100, 132, 180, 225, 280, and 355 indicate the max. motor shaft height in mm for the individual rail types.

The numbers following the slash (6, 8, 10, 12, 16, 20, 24) indicate the thread diameters of the fixing bolts (6 = M6).

The letters VS and GS indicate the design of the adjusting screw bracket:

- VS = sliding bracket
- GS = fixed bracket

Slide rail part number N 300, N 400, and N 600 are not standardised. They are longer than the standard slide rails but all of the same spare parts can be used.

One set of slide rails consists of 2 rails with all fixing parts.

Motorspannschlitten Motor slide bases

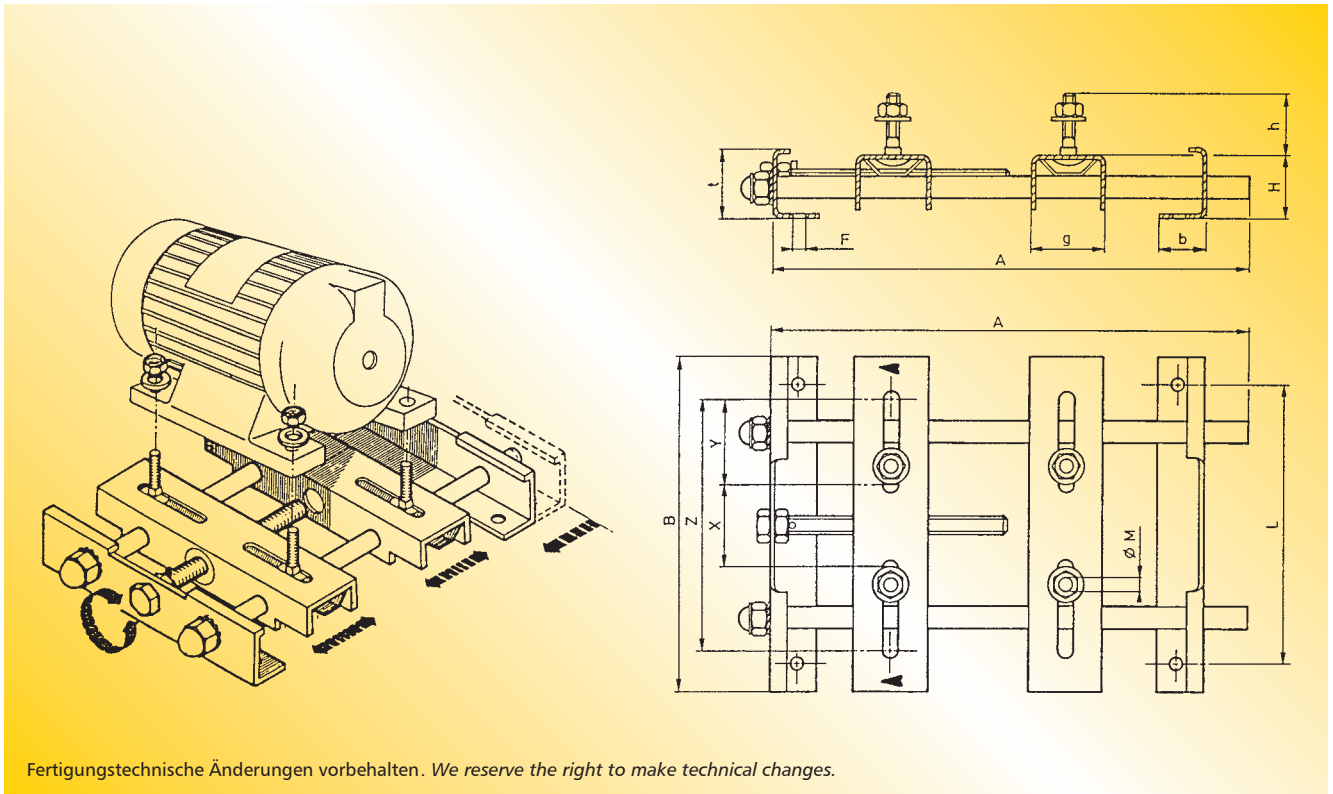

Fertigungstechnische Änderungen vorbehalten. We reserve the right to make technical changes.

Bezeichnung Part number	MS 100	MS 132
Motorachshöhe Motor shaft centre height Ha (mm)	100,0	132,0
A (mm)	300,0	450,0
B (mm)	180,0	265,0
F (mm)	10,0	13,0
H (mm)	35,0	50,0
L (mm)	150,0	225,0
M	M 8 x 35	M 10 x 40
b (mm)	30,0	45,0
g (mm)	40,0	55,0
h (mm)	35,0	40,0
t (mm)	40,0	55,0
u (mm)	25,0	35,0
v (mm)	20,0	25,0
w (mm)	9,0	18,0
x (mm)	46,0	105,0
y (mm)	50,0	50,0
z (mm)	145,0	204,0
Gewicht Weight (≈ kg)	2,180	4,520
€/Stück each	auf Anfrage / on request	

Standard-Zahnscheiben für zylindrische Bohrung Timing belt pulleys for plain boring

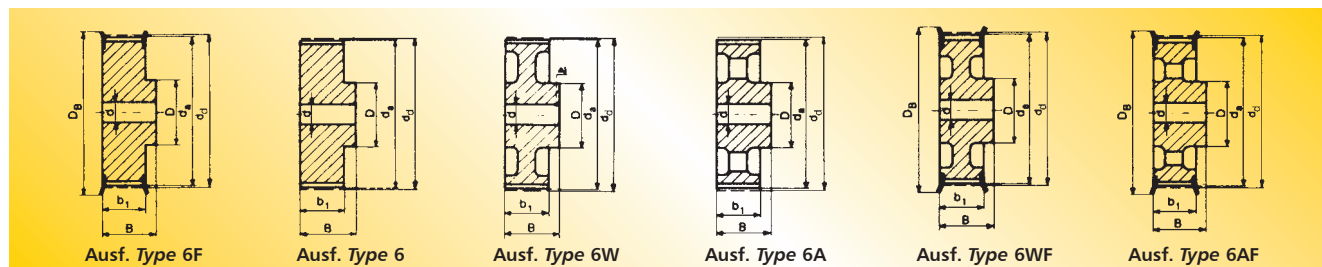

Type XL – Teilung Pitch 5,08 mm für Riemenbreite for belt width 025, 031, 037

Bezeichnung Part No.	Anzahl der Zähne No. of teeth	Aus- führung Type	Material	d _d (mm)	d _s (mm)	D _B (mm)	b ₁ (mm)	B (mm)	D (mm)	Vor- bohrung Pilot bore d (mm)	Fertig- bohrung Finished bore d _{max} (mm)	Gewicht Weight (≈ kg)	€ Stück each
10 XL 037	10	6F	St	16,17	15,66	23	14,3	19,8	9,5	5,0	6,4	0,02	auf Anfrage on request
11 XL 037	11	6F	St	17,79	17,28	23	14,3	19,8	9,5	5,0	6,4	0,02	
12 XL 037	12	6F	St	19,40	18,89	25	14,3	19,8	12,7	5,0	7,9	0,03	
14 XL 037	14	6F	St	22,64	22,13	28	14,3	19,8	14,3	6,0	9,5	0,04	
15 XL 037	15	6F	St	24,26	23,75	28	14,3	19,8	15,9	6,0	11,1	0,04	
16 XL 037	16	6F	St	25,87	25,36	32	14,3	19,8	17,5	6,0	12,7	0,05	
18 XL 037	18	6F	St	29,11	28,60	36	14,3	19,8	19,0	6,0	14,3	0,06	
20 XL 037	20	6F	St	32,34	31,83	38	14,3	22,2	23,8	6,0	17,5	0,08	
21 XL 037	21	6F	St	33,96	33,45	38	14,3	22,2	23,8	6,0	17,5	0,09	
22 XL 037	22	6F	St	35,57	35,06	42	14,3	22,2	25,4	6,0	19,1	0,10	
24 XL 037	24	6F	St	38,81	38,30	44	14,3	22,2	27,0	6,0	20,6	0,12	
26 XL 037	26	6F	St	42,04	41,53	48	14,3	22,2	30,0	6,0	23,0	0,14	
28 XL 037	28	6F	St	45,28	44,77	51	14,3	22,2	30,2	6,0	23,0	0,16	
30 XL 037	30	6F	St	48,51	48,00	54	14,3	22,2	34,9	6,0	23,0	0,19	
32 XL 037	32	6	Al	51,74	51,23	—	14,3	25,4	38,0	8,0	23,0	0,11	
36 XL 037	36	6	Al	58,21	57,70	—	14,3	25,4	38,0	8,0	23,0	0,13	
40 XL 037	40	6	Al	64,68	64,17	—	14,3	25,4	38,0	8,0	23,0	0,17	
42 XL 037	42	6WF	Al	67,91	67,40	—	14,3	25,4	38,0	8,0	23,0	0,13	
44 XL 037	44	6WF	Al	71,15	70,64	—	14,3	25,4	38,0	8,0	23,0	0,15	
48 XL 037	48	6WF	Al	77,62	77,11	—	14,3	25,4	38,0	8,0	23,0	0,16	
60 XL 037	60	6A	Al	97,02	96,51	—	14,3	25,4	38,0	8,0	23,0	0,18	
72 XL 037	72	6A	Al	116,43	115,92	—	14,3	25,4	38,0	8,0	23,0	0,23	

Type L – Teilung Pitch 9,525 mm für Riemenbreite for belt width 050

10 L 050	10	6F	St	30,32	29,56	36	19	26	22	6,0	13,0	0,11	auf Anfrage on request
12 L 050	12	6F	St	36,38	35,62	42	19	26	28	6,0	17,0	0,19	
13 L 050	13	6F	St	39,41	38,65	44	19	26	28	6,0	19,0	0,21	
14 L 050	14	6F	St	42,45	41,68	48	19	26	33	8,0	20,0	0,25	
15 L 050	15	6F	St	45,48	44,72	51	19	26	36	8,0	23,0	0,30	
16 L 050	16	6F	St	48,51	47,75	54	19	26	38	8,0	23,0	0,33	
17 L 050	17	6F	St	51,54	50,78	57	19	26	40	10,0	24,0	0,36	
18 L 050	18	6F	St	54,57	53,81	60	19	26	40	10,0	24,0	0,41	
19 L 050	19	6F	St	57,61	56,84	60	19	26	40	10,0	24,0	0,45	
20 L 050	20	6F	St	60,64	59,88	66	19	26	46	10,0	28,0	0,50	
21 L 050	21	6F	St	63,67	62,91	71	19	26	46	10,0	28,0	0,55	
22 L 050	22	6F	St	66,70	65,94	75	19	26	50	10,0	30,0	0,62	
24 L 050	24	6F	St	72,77	72,00	79	19	26	50	12,0	30,0	0,68	
26 L 050	26	6F	St	78,83	78,07	87	19	26	50	12,0	30,0	0,82	
28 L 050	28	6F	St	84,89	84,13	91	19	26	50	12,0	30,0	0,92	
30 L 050	30	6F	St	90,96	90,20	97	19	26	50	12,0	30,0	1,10	
32 L 050	32	6F	St	97,02	96,26	103	19	26	50	12,0	30,0	1,20	
36 L 050	36	6WF	GG	109,15	108,38	115	19	26	50	12,0	30,0	1,00	
40 L 050	40	6WF	GG	121,28	120,51	127	19	26	50	12,0	30,0	1,10	
44 L 050	44	6AF	GG	133,40	132,64	140	19	26	50	12,0	30,0	1,20	
48 L 050	48	6AF	GG	145,53	144,77	152	19	26	50	12,0	30,0	1,30	
60 L 050	60	6A	GG	181,91	181,15	—	19	28	50	15,0	30,0	1,30	
72 L 050	72	6A	GG	218,30	217,53	—	19	28	50	15,0	30,0	1,70	
84 L 050	84	6A	GG	254,68	253,92	—	19	28	50	15,0	30,0	1,90	

St = Stahl Steel Al = Aluminium GG = Grauguss Cast iron

Fertigungstechnische Änderungen vorbehalten. We reserve the right to make technical changes.

Standard-Zahnscheiben für zylindrische Bohrung Timing belt pulleys for plain boring

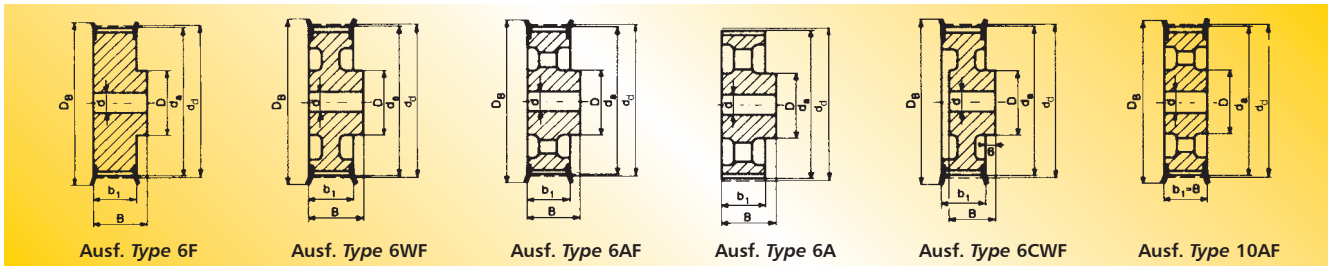

Type L – Teilung Pitch 9,525 mm für Riemenbreite for belt width 075

Bezeichnung Part No.	Anzahl der Zähne No. of teeth	Aus- führung Type	Material	d _d (mm)	d _s (mm)	D _B (mm)	b ₁ (mm)	B (mm)	D (mm)	Vor- bohrung Pilot bore d (mm)	Fertig- bohrung Finished bore d _{max} (mm)	Gewicht Weight (≈ kg)	€ Stück each
10 L 075	10	6F	St	30,32	29,56	36	25	32	22	6	13	0,15	auf Anfrage on request
12 L 075	12	6F	St	36,38	35,62	42	25	32	28	8	17	0,23	
13 L 075	13	6F	St	39,41	38,65	44	25	32	30	8	19	0,26	
14 L 075	14	6F	St	42,45	41,68	48	25	32	33	8	20	0,32	
15 L 075	15	6F	St	45,48	44,72	51	25	32	36	8	23	0,35	
16 L 075	16	6F	St	48,51	47,75	54	25	32	38	8	23	0,42	
17 L 075	17	6F	St	51,54	50,78	57	25	32	40	10	24	0,45	
18 L 075	18	6F	St	54,57	53,81	60	25	32	40	10	24	0,51	
19 L 075	19	6F	St	57,61	56,84	60	25	32	40	10	24	0,57	
20 L 075	20	6F	St	60,64	59,88	66	25	32	46	10	28	0,63	
21 L 075	21	6F	St	63,67	62,91	71	25	32	46	10	28	0,70	
22 L 075	22	6F	St	66,70	65,94	75	25	32	50	10	30	0,75	
24 L 075	24	6F	St	72,77	72,00	79	25	32	50	12	30	0,85	
26 L 075	26	6F	St	78,83	78,07	87	25	32	50	12	30	1,00	
28 L 075	28	6F	St	84,89	84,13	91	25	32	50	12	30	1,20	
30 L 075	30	6F	St	90,96	90,20	97	25	32	50	12	30	1,40	
32 L 075	32	6F	St	97,02	96,26	103	25	32	50	12	30	1,50	
36 L 075	36	6WF	GG	109,15	108,38	115	25	32	55	12	32	1,30	
40 L 075	40	6WF	GG	121,28	120,51	127	25	32	60	12	35	1,60	
44 L 075	44	6AF	GG	133,40	132,64	140	25	32	60	12	35	1,70	
48 L 075	48	6AF	GG	145,53	144,77	152	25	32	60	12	35	1,90	
60 L 075	60	6A	GG	181,91	181,15	—	26	35	60	15	35	1,80	
72 L 075	72	6A	GG	218,30	217,53	—	26	35	60	15	35	2,30	
84 L 075	84	6A	GG	254,68	253,92	—	26	35	60	15	35	2,50	

Type L – Teilung Pitch 9,525 mm für Riemenbreite for belt width 100

10 L 100	10	6F	St	30,32	29,56	36	31	38	22	6	13	0,81	auf Anfrage on request
12 L 100	12	6F	St	36,38	35,62	42	31	38	28	8	17	0,29	
13 L 100	13	6F	St	39,41	38,65	44	31	38	28	8	19	0,30	
14 L 100	14	6F	St	42,45	41,68	48	31	38	33	8	20	0,38	
15 L 100	15	6F	St	45,48	44,72	51	31	38	36	8	23	0,40	
16 L 100	16	6F	St	48,51	47,75	54	31	38	38	8	23	0,51	
17 L 100	17	6F	St	51,54	50,78	57	31	38	40	10	24	0,54	
18 L 100	18	6F	St	54,57	53,81	60	31	38	40	10	24	0,62	
19 L 100	19	6F	St	57,61	56,84	60	31	38	40	10	24	0,69	
20 L 100	20	6F	St	60,64	59,88	66	31	38	46	10	28	0,76	
21 L 100	21	6F	St	63,67	62,91	71	31	38	46	10	28	0,82	
22 L 100	22	6F	St	66,70	65,94	75	31	38	50	10	30	0,92	
24 L 100	24	6F	St	72,77	72,00	79	31	38	50	12	30	1,10	
26 L 100	26	6F	St	78,83	78,07	87	31	38	50	12	30	1,30	
28 L 100	28	6F	St	84,89	84,13	91	31	38	50	12	30	1,40	
30 L 100	30	6F	St	90,96	90,20	97	31	38	50	12	30	1,70	
32 L 100	32	6F	St	97,02	96,26	103	31	38	50	12	30	1,80	
36 L 100	36	6CWF	GG	109,15	108,38	115	32	32	55	12	32	1,50	
40 L 100	40	6CWF	GG	121,28	120,51	127	32	32	60	12	35	1,80	
44 L 100	44	10AF	GG	133,40	132,64	140	32	32	60	12	35	1,90	
48 L 100	48	10AF	GG	145,53	144,77	152	32	32	60	12	35	2,10	
60 L 100	60	6A	GG	181,91	181,15	—	32	35	60	15	35	2,00	
72 L 100	72	6A	GG	218,30	217,53	—	32	35	60	15	35	2,50	
84 L 100	84	6A	GG	254,68	253,92	—	32	35	60	15	35	2,70	

St = Stahl Steel GG = Grauguss Cast iron

Fertigungstechnische Änderungen vorbehalten. We reserve the right to make technical changes.

Standard-Zahnscheiben für zylindrische Bohrung

Timing belt pulleys for plain boring

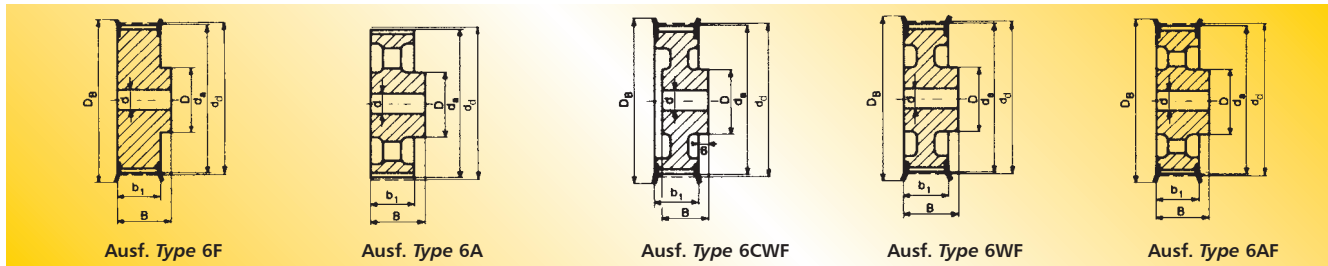

Type H – Teilung *Pitch* 12,7 mm für Riemenbreite *for belt width* 075

Bezeichnung Part No.	Anzahl der Zähne No. of teeth	Aus- führung Type	Material	d _d (mm)	d _s (mm)	D _B (mm)	b ₁ (mm)	B (mm)	D (mm)	Vor- bohrung Pilot bore d (mm)	Fertig- bohrung Finished bore d _{max} (mm)	Gewicht Weight (≈ kg)	€ Stück each
14 H 075	14	6F	St	56,60	55,22	64,0	26,4	40	40	10	24	0,50	auf Anfrage on request
16 H 075	16	6F	St	64,67	63,31	70,0	26,4	40	46	10	26	0,60	
18 H 075	18	6F	St	72,77	71,39	79,0	26,4	40	54	12	32	0,80	
19 H 075	19	6F	St	76,81	75,44	82,5	26,4	40	58	12	35	1,00	
20 H 075	20	6F	St	80,85	79,48	87,0	26,4	40	62	12	35	1,10	
21 H 075	21	6F	St	84,89	83,52	91,0	26,4	40	67	12	38	1,20	
22 H 075	22	6F	St	88,94	87,56	94,0	26,4	40	70	12	38	1,40	
24 H 075	24	6F	St	97,02	95,65	102,0	26,4	40	75	12	42	1,60	
26 H 075	26	6F	St	105,11	103,73	112,0	26,4	40	80	15	45	1,80	
28 H 075	28	6F	GG	113,19	111,82	120,0	26,4	40	80	15	45	2,00	
30 H 075	30	6F	GG	121,28	119,90	128,0	26,4	40	80	15	45	2,10	
32 H 075	32	6F	GG	129,36	127,99	135,0	26,4	40	70	15	45	2,20	
36 H 075	36	6F	GG	145,53	144,16	152,0	26,4	40	80	20	45	2,40	
40 H 075	40	6F	GG	161,70	160,33	168,0	26,4	40	80	20	45	2,80	
44 H 075	44	6AF	GG	177,87	176,50	184,0	26,4	40	80	20	45	2,70	
48 H 075	48	6AF	GG	194,04	192,67	200,0	26,4	40	90	20	50	3,00	

Type H – Teilung *Pitch* 12,7 mm für Riemenbreite *for belt width* 100

14 H 100	14	6F	St	56,60	55,22	63	31	41	40	10	24	0,65	auf Anfrage on request
16 H 100	16	6F	St	64,68	63,31	71	31	41	46	10	28	0,85	
18 H 100	18	6F	St	72,77	71,39	79	31	41	54	12	32	1,10	
19 H 100	19	6F	St	76,81	75,44	83	31	41	58	12	34	1,20	
20 H 100	20	6F	St	80,85	79,48	87	31	41	62	12	35	1,40	
21 H 100	21	6F	St	84,89	83,52	91	31	41	67	12	38	1,60	
22 H 100	22	6F	St	88,94	87,56	93	31	41	70	12	41	1,70	
24 H 100	24	6F	St	97,02	95,65	103	31	41	75	12	45	2,00	
26 H 100	26	6CWF	GG	105,11	103,73	111	32	32	55	15	32	1,40	
28 H 100	28	6CWF	GG	113,19	111,82	119	32	32	60	15	35	1,60	
30 H 100	30	6CWF	GG	121,28	119,90	127	32	32	60	15	35	1,70	
32 H 100	32	6WF	GG	129,36	127,99	135	32	40	70	20	40	2,20	
36 H 100	36	6WF	GG	145,53	144,16	152	32	40	80	20	45	3,00	
40 H 100	40	6AF	GG	161,70	160,33	168	32	40	80	20	45	2,80	
44 H 100	44	6AF	GG	177,87	176,50	184	32	40	80	20	45	3,10	
48 H 100	48	6AF	GG	194,04	192,67	200	32	40	80	20	45	3,30	
60 H 100	60	6A	GG	242,55	241,18	—	34	45	80	20	45	5,50	
72 H 100	72	6A	GG	291,06	289,69	—	34	45	80	20	45	7,10	
84 H 100	84	6A	GG	339,57	338,20	—	34	45	80	20	45	8,20	
96 H 100	96	6A	GG	388,08	386,71	—	34	45	80	20	45	9,90	
120 H 100	120	6A	GG	485,10	483,73	—	34	50	90	20	50	13,10	

St = Stahl Steel GG = Grauguss Cast iron

Fertigungstechnische Änderungen vorbehalten. We reserve the right to make technical changes.

Standard-Zahnscheiben für zylindrische Bohrung Timing belt pulleys for plain boring

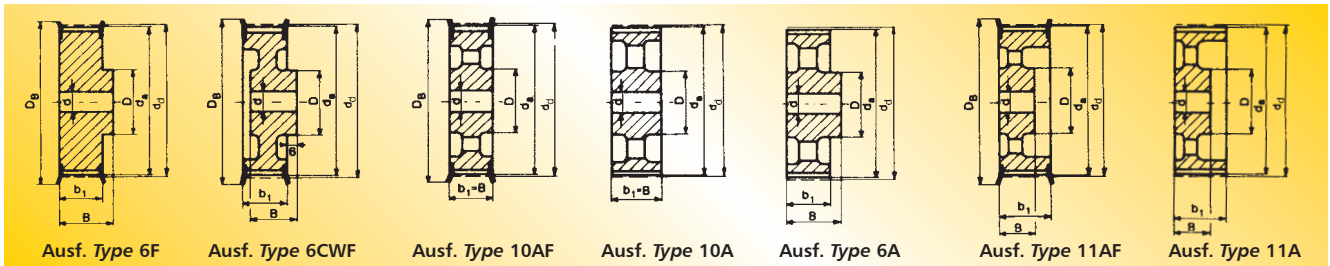

Type H – Teilung Pitch 12,7 mm für Riemenbreite for belt width 150

Bezeichnung Part No.	Anzahl der Zähne No. of teeth	Aus- führung Type	Material	d _d (mm)	d _s (mm)	D _B (mm)	b ₁ (mm)	B (mm)	D (mm)	Vor- bohrung Pilot bore d (mm)	Fertig- bohrung Finished bore d _{max} (mm)	Gewicht Weight (≈ kg)	€ Stück each
14 H 150	14	6F	St	56,60	55,22	63	44	54	40	12	24	0,82	auf Anfrage on request
16 H 150	16	6F	St	64,68	63,31	71	44	54	46	12	28	1,10	
18 H 150	18	6F	St	72,77	71,39	79	44	54	54	12	32	1,50	
19 H 150	19	6F	St	76,81	75,44	83	44	54	58	12	34	1,70	
20 H 150	20	6F	St	80,85	79,48	87	44	54	62	12	35	1,80	
21 H 150	21	6F	St	84,89	83,52	91	44	54	67	12	38	2,20	
22 H 150	22	6F	St	88,94	87,56	93	44	54	70	12	41	2,30	
24 H 150	24	6F	St	97,02	95,65	103	44	54	75	12	45	2,60	
26 H 150	26	6CWF	GG	105,11	103,73	111	45	35	55	15	32	1,70	
28 H 150	28	6CWF	GG	113,19	111,82	119	45	35	60	15	35	1,90	
30 H 150	30	6CWF	GG	121,28	119,90	127	45	35	60	15	35	2,10	
32 H 150	32	6CWF	GG	129,36	127,99	135	45	45	70	20	40	2,60	
36 H 150	36	6CWF	GG	145,53	144,16	152	45	45	80	20	45	3,20	
40 H 150	40	10AF	GG	161,70	160,33	168	45	45	80	20	45	3,80	
44 H 150	44	10AF	GG	177,87	176,50	184	45	45	80	20	45	3,70	
48 H 150	48	10AF	GG	194,04	192,67	200	45	45	80	20	45	4,00	
60 H 150	60	10A	GG	242,55	241,18	—	46	46	85	20	48	5,10	
72 H 150	72	10A	GG	291,06	289,69	—	46	46	85	20	48	7,90	
84 H 150	84	10A	GG	339,57	338,20	—	46	46	85	20	48	8,90	
96 H 150	96	10A	GG	388,08	386,71	—	46	46	85	20	48	10,10	
120 H 150	120	6A	GG	485,10	483,73	—	46	55	95	24	55	17,20	

Type H – Teilung Pitch 12,7 mm für Riemenbreite for belt width 200

14 H 200	14	6F	St	56,60	55,22	63	58	68	40	12	24	1,1	auf Anfrage on request
16 H 200	16	6F	St	64,68	63,31	71	58	68	46	15	28	1,4	
18 H 200	18	6F	St	72,77	71,39	79	58	68	54	15	32	1,8	
19 H 200	19	6F	St	76,81	75,44	83	58	68	58	15	34	2,1	
20 H 200	20	6F	St	80,85	79,48	87	58	68	62	15	35	2,3	
21 H 200	21	6F	St	84,89	83,52	91	58	68	67	15	38	2,6	
22 H 200	22	6F	St	88,94	87,56	93	58	68	70	15	41	2,8	
24 H 200	24	6F	St	97,02	95,65	103	58	68	75	15	45	3,4	
26 H 200	26	6CWF	GG	105,11	103,73	111	58	42	60	15	35	2,3	
28 H 200	28	6CWF	GG	113,19	111,82	119	58	42	60	15	35	2,5	
30 H 200	30	6CWF	GG	121,28	119,90	127	58	42	70	15	40	2,9	
32 H 200	32	6CWF	GG	129,36	127,99	135	58	47	70	20	40	3,2	
36 H 200	36	6CWF	GG	145,53	144,16	152	58	47	80	20	45	3,8	
40 H 200	40	11AF	GG	161,70	160,33	168	58	45	80	20	45	4,1	
44 H 200	44	11AF	GG	177,87	176,50	184	58	45	80	20	45	4,4	
48 H 200	48	11AF	GG	194,04	192,67	200	58	45	85	20	48	5,1	
60 H 200	60	11A	GG	242,55	241,18	—	60	50	90	20	50	7,1	
72 H 200	72	11A	GG	291,06	289,69	—	60	50	90	20	50	8,0	
84 H 200	84	11A	GG	339,57	338,20	—	60	50	90	20	50	12,0	
96 H 200	96	11A	GG	388,08	386,71	—	60	50	90	20	50	13,6	
120 H 200	120	10A	GG	485,10	483,73	—	60	60	100	24	57	16,6	

Standard-Zahnscheiben für zylindrische Bohrung

Timing belt pulleys for plain boring

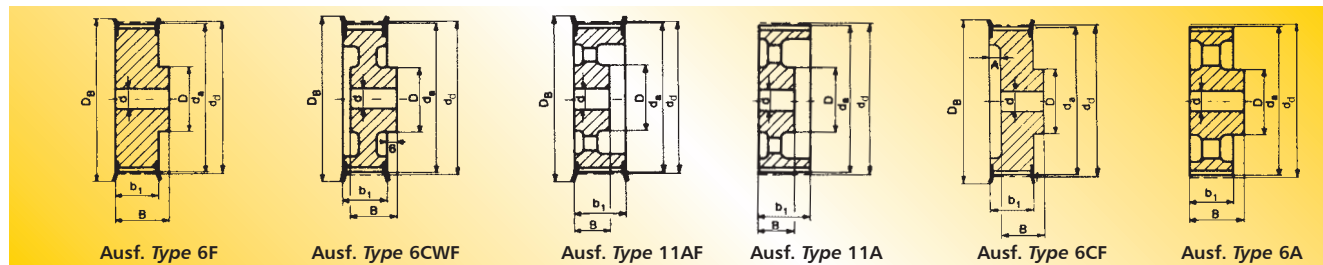

Type H – Teilung *Pitch* 12,7 mm für Riemenbreite *for belt width* 300

Bezeichnung Part No.	Anzahl der Zähne No. of teeth	Aus- führung Type	Material	d _d (mm)	d _s (mm)	D _B (mm)	b ₁ (mm)	B (mm)	D (mm)	A (mm)	Vor- bohrung Pilot bore d (mm)	Fertig- bohrung Finished bore d _{max} (mm)	Gewicht Weight (≈ kg)	€ Stück each
16 H 300	16	6F	St	64,68	63,31	71	84	94	46	—	15	28	2,0	auf Anfrage on request
18 H 300	18	6F	St	72,77	71,39	79	84	94	54	—	15	32	2,6	
19 H 300	19	6F	St	76,81	75,44	83	84	94	58	—	15	34	2,9	
20 H 300	20	6F	St	80,85	79,48	87	84	94	62	—	15	35	3,2	
21 H 300	21	6F	St	84,89	83,52	91	84	94	67	—	15	38	3,6	
22 H 300	22	6F	St	88,94	87,56	93	84	94	70	—	15	41	4,0	
24 H 300	24	6F	St	97,02	95,65	103	84	94	75	—	15	45	4,7	
26 H 300	26	6CWF	GG	105,11	103,73	111	84	57	60	—	15	35	3,3	
28 H 300	28	6CWF	GG	113,19	111,82	119	84	57	60	—	15	35	3,6	
30 H 300	30	6CWF	GG	121,28	119,90	127	84	57	70	—	15	40	4,2	
32 H 300	32	6CWF	GG	129,36	127,99	135	84	57	70	—	20	40	4,3	
36 H 300	36	6CWF	GG	145,53	144,16	152	84	57	80	—	20	45	5,2	
40 H 300	40	11AF	GG	161,70	160,33	168	84	55	80	—	20	45	5,6	
44 H 300	44	11AF	GG	177,87	176,50	184	84	55	80	—	20	45	5,9	
48 H 300	48	11AF	GG	194,04	192,67	200	84	55	85	—	20	48	6,6	
60 H 300	60	11A	GG	242,55	241,18	—	86	55	100	—	20	57	9,9	
72 H 300	72	11A	GG	291,06	289,69	—	86	55	100	—	20	57	13,0	
84 H 300	84	11A	GG	339,57	338,20	—	86	55	100	—	20	57	15,1	
96 H 300	96	11A	GG	388,08	386,71	—	86	55	100	—	20	57	18,2	
120 H 300	120	11A	GG	485,10	483,73	—	86	65	110	—	24	62	26,0	

Type XH – Teilung *Pitch* 22,225 mm für Riemenbreite *for belt width* 200

18 XH 200	18	6CF	GG	127,34	124,55	142	64,4	60	85	18	20	50	5,0	auf Anfrage on request
20 XH 200	20	6CF	GG	141,49	138,69	155	64,4	60	95	18	20	55	6,0	
22 XH 200	22	6CF	GG	155,64	152,84	170	64,4	60	110	18	20	65	7,2	
24 XH 200	24	6CF	GG	169,79	166,69	184	64,4	60	125	18	25	70	8,6	
26 XH 200	26	6CF	GG	183,94	181,14	198	64,4	60	140	18	25	80	10,1	
28 XH 200	28	6CWF	GG	198,08	195,29	212	64,4	60	120	18	25	70	9,6	
30 XH 200	30	6CWF	GG	212,23	209,44	227	64,4	60	120	18	25	70	10,4	
32 XH 200	32	6CWF	GG	226,38	223,59	240	64,4	60	130	18	25	75	11,2	
40 XH 200	40	6CWF	GG	282,98	280,18	297	64,4	60	140	18	25	80	16,0	
48 XH 200	48	6A	GG	339,57	336,78	—	65,0	80	150	—	30	85	18,4	
60 XH 200	60	6A	GG	424,47	421,67	—	65,0	80	150	—	30	85	24,3	
72 XH 200	72	6A	GG	509,36	506,57	—	65,0	80	150	—	40	85	28,1	
84 XH 200	84	6A	GG	594,25	591,46	—	65,0	80	160	—	40	90	31,9	
96 XH 200	96	6A	GG	679,15	676,35	—	65,0	80	160	—	40	90	37,0	

St = Stahl Steel GG = Grauguss Cast iron

Fertigungstechnische Änderungen vorbehalten. We reserve the right to make technical changes.

Standard-Zahnscheiben für zylindrische Bohrung Timing belt pulleys for plain boring

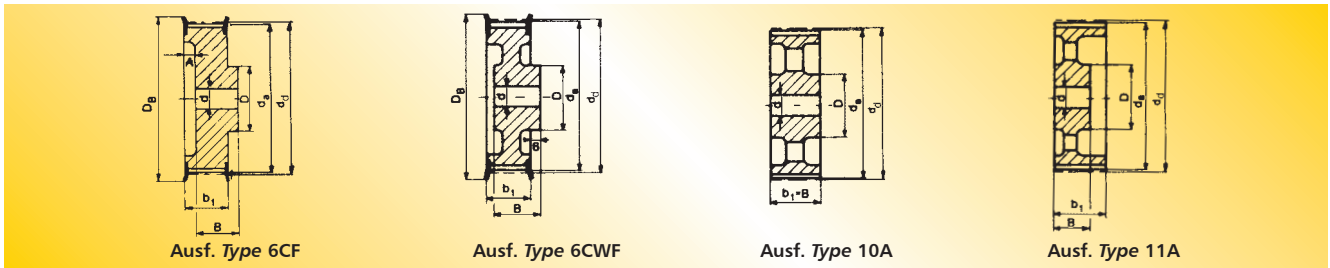

Type XH – Teilung Pitch 22,225 mm für Riemenbreite for belt width 300

Bezeichnung Part No.	Anzahl der Zähne No. of teeth	Aus- führung Type	Material	d _d (mm)	d _s (mm)	D _B (mm)	b ₁ (mm)	B (mm)	D (mm)	A (mm)	Vor- bohrung Pilot bore d (mm)	Fertig- bohrung Finished bore d _{max} (mm)	Gewicht Weight (≈ kg)	€ Stück each
18 XH 300	18	6CF	GG	127,34	124,55	142	91,4	70	85	35	20	50	6,8	auf Anfrage on request
20 XH 300	20	6CF	GG	141,49	138,69	155	91,4	70	95	35	20	55	7,4	
22 XH 300	22	6CF	GG	155,64	152,84	170	91,4	70	110	35	20	65	9,0	
24 XH 300	24	6CF	GG	169,79	166,69	184	91,4	70	125	35	25	70	10,6	
26 XH 300	26	6CF	GG	183,94	181,14	198	91,4	70	140	35	25	80	13,0	
28 XH 300	28	6CWF	GG	198,08	195,29	212	91,4	70	120	35	25	70	12,0	
30 XH 300	30	6CWF	GG	212,23	209,44	227	91,4	70	120	35	25	70	13,0	
32 XH 300	32	6CWF	GG	226,38	223,59	240	91,4	70	130	35	25	75	14,7	
40 XH 300	40	6CWF	GG	282,98	280,18	297	91,4	70	140	35	25	80	19,9	
48 XH 300	48	10A	GG	339,57	336,78	—	92,0	92	150	—	30	85	22,5	
60 XH 300	60	10A	GG	424,47	421,67	—	92,0	92	150	—	30	85	31,5	
72 XH 300	72	10A	GG	509,36	506,57	—	92,0	92	150	—	40	85	36,4	
84 XH 300	84	10A	GG	594,25	591,46	—	92,0	92	160	—	40	90	43,4	
96 XH 300	96	10A	GG	679,15	676,35	—	92,0	92	160	—	40	90	48,5	

Type XH – Teilung Pitch 22,225 mm für Riemenbreite for belt width 400

18 XH 400	18	6CF	GG	127,34	124,55	142	118,4	85	85	47	20	50	8,5	auf Anfrage on request
20 XH 400	20	6CF	GG	141,49	138,69	155	118,4	85	95	47	20	55	9,4	
22 XH 400	22	6CF	GG	155,64	152,84	170	118,4	85	110	47	20	65	11,5	
24 XH 400	24	6CF	GG	169,79	166,69	184	118,4	85	125	47	25	70	13,4	
26 XH 400	26	6CF	GG	183,94	181,14	198	118,4	85	140	47	25	80	15,6	
28 XH 400	28	6CWF	GG	198,08	195,29	212	118,4	85	120	47	25	70	14,5	
30 XH 400	30	6CWF	GG	212,23	209,44	227	118,4	85	120	47	25	70	16,0	
32 XH 400	32	6CWF	GG	226,38	223,59	240	118,4	85	130	47	25	75	18,0	
40 XH 400	40	6CWF	GG	282,98	280,18	297	118,4	85	140	47	25	80	24,0	
48 XH 400	48	11A	GG	339,57	336,78	—	119,0	92	150	—	30	85	30,8	
60 XH 400	60	11A	GG	424,47	421,67	—	119,0	92	150	—	30	85	36,2	
72 XH 400	72	11A	GG	509,36	506,57	—	119,0	92	150	—	40	85	42,7	
84 XH 400	84	11A	GG	594,25	591,46	—	119,0	92	160	—	40	90	49,7	
96 XH 400	96	11A	GG	679,15	676,35	—	119,0	92	160	—	40	90	59,9	

Standard-Zahnscheiben für Taperbuchsen

Timing belt pulleys for taper bushes

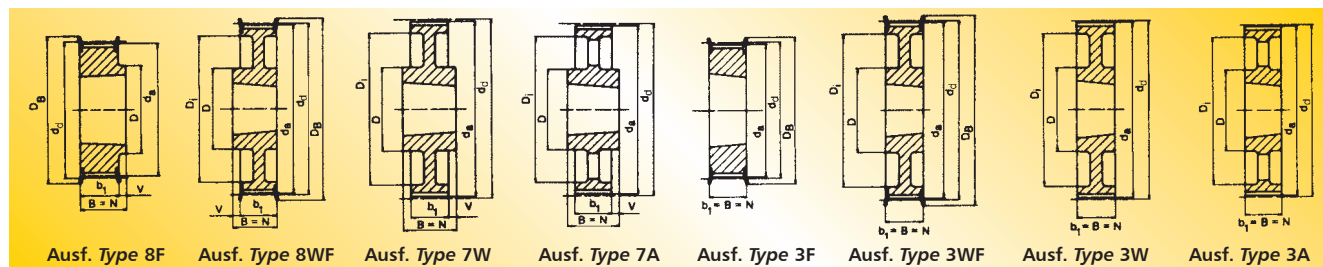

Type L – Teilung *Pitch* 9,525 mm für Riemenbreite *for belt width* 050

Bezeichnung Part No.	Anzahl der Zähne No. of teeth	Aus- führung Type	Material	d _d (mm)	d _s (mm)	D _B (mm)	b ₁ (mm)	B (mm)	N (mm)	V (mm)	Z (mm)	D (mm)	D _i (mm)	Taper- Buchse Taper bush	Gewicht ohne Buchse Weight without bush (≈ kg)	€ Stück ohne Buchse each without bush
TB 18 L 050	18	8F	St	54,57	53,81	60	19,0	22,0	22,0	3,0	—	44	—	1108	0,2	auf Anfrage on request
TB 19 L 050	19	8F	St	57,61	56,84	60	19,0	22,0	22,0	3,0	—	44	—	1108	0,2	
TB 20 L 050	20	8F	St	60,64	59,88	66	19,0	22,0	22,0	3,0	—	48	—	1108	0,2	
TB 21 L 050	21	8F	St	63,67	62,91	71	19,0	22,0	22,0	3,0	—	48	—	1108	0,3	
TB 22 L 050	22	8F	St	66,70	65,94	75	19,0	22,0	22,0	3,0	—	51	—	1108	0,3	
TB 23 L 050	23	8F	GG	69,73	68,97	79	19,0	22,0	22,0	3,0	—	54	—	1108	0,4	
TB 24 L 050	24	8F	GG	72,77	72,00	79	19,0	22,0	22,0	3,0	—	54	—	1108	0,4	
TB 25 L 050	25	8F	GG	75,80	75,04	83	19,0	22,0	22,0	3,0	—	56	—	1108	0,5	
TB 26 L 050	26	8F	GG	78,83	78,07	87	19,0	22,0	22,0	3,0	—	60	—	1108	0,5	
TB 27 L 050	27	8F	GG	81,86	81,10	87	19,0	22,0	22,0	3,0	—	65	—	1108	0,6	
TB 28 L 050	28	8F	GG	84,89	84,13	91	19,0	22,0	22,0	3,0	—	65	—	1108	0,6	
TB 30 L 050	30	8F	GG	90,96	90,20	97	19,0	22,0	22,0	3,0	—	70	—	1108	0,8	
TB 32 L 050	32	8F	GG	97,02	96,26	103	19,0	22,0	22,0	3,0	—	74	—	1108	0,9	
TB 36 L 050	36	8F	GG	109,15	108,39	115	19,0	22,0	22,0	3,0	—	87	—	1108	1,2	
TB 40 L 050	40	8F	GG	121,28	120,51	127	19,0	25,0	25,0	6,0	—	97	—	1610	1,5	
TB 48 L 050	48	8WF	GG	145,53	144,77	152	19,0	25,0	25,0	6,0	—	88	124	1610	2,3	
TB 60 L 050	60	7W	GG	181,91	181,15	—	19,0	25,0	25,0	3,0	—	92	166	1610	2,0	
TB 72 L 050	72	7A	GG	218,30	217,53	—	19,0	25,0	25,0	3,0	—	92	202	1610	3,0	
TB 84 L 050	84	7A	GG	254,68	253,90	—	19,0	25,0	25,0	3,0	—	92	236	1610	4,0	
TB 96 L 050	96	7A	GG	291,06	290,30	—	19,0	32,0	32,0	6,5	—	106	270	2012	5,5	
TB 120 L 050	120	7A	GG	363,83	363,07	—	19,0	32,0	32,0	6,5	—	106	343	2012	6,8	

Type L – Teilung *Pitch* 9,525 mm für Riemenbreite *for belt width* 075

TB 18 L 075	18	3F	St	54,57	53,81	60	25,0	25,0	25,0	—	—	—	—	1108	0,2	auf Anfrage on request
TB 19 L 075	19	3F	St	57,61	56,84	60	25,0	25,0	25,0	—	—	—	—	1108	0,3	
TB 20 L 075	20	3F	St	60,64	59,88	66	25,0	25,0	25,0	—	—	—	—	1108	0,3	
TB 21 L 075	21	3F	St	63,67	62,91	71	25,0	25,0	25,0	—	—	—	—	1108	0,4	
TB 22 L 075	22	3F	St	66,70	65,94	75	25,0	25,0	25,0	—	—	—	—	1108	0,4	
TB 23 L 075	23	3F	GG	69,73	68,97	79	25,0	25,0	25,0	—	—	—	—	1108	0,4	
TB 24 L 075	24	3F	GG	72,77	72,00	79	25,0	25,0	25,0	—	—	—	—	1108	0,5	
TB 25 L 075	25	3F	GG	75,80	75,04	83	25,0	25,0	25,0	—	—	—	—	1108	0,6	
TB 26 L 075	26	3F	GG	78,83	78,07	87	25,0	25,0	25,0	—	—	—	—	1108	0,6	
TB 27 L 075	27	3F	GG	81,86	81,10	87	25,0	25,0	25,0	—	—	—	—	1108	0,7	
TB 28 L 075	28	3F	GG	84,89	84,13	91	25,0	25,0	25,0	—	—	—	—	1108	0,7	
TB 30 L 075	30	3F	GG	90,96	90,20	97	25,0	25,0	25,0	—	—	—	—	1108	0,9	
TB 32 L 075	32	3F	GG	97,02	96,26	103	25,0	25,0	25,0	—	—	—	—	1108	1,0	
TB 36 L 075	36	3F	GG	109,15	108,39	115	25,0	25,0	25,0	—	—	—	—	1610	1,2	
TB 40 L 075	40	3F	GG	121,28	120,51	127	25,0	25,0	25,0	—	—	—	—	1610	1,7	
TB 48 L 075	48	3WF	GG	145,53	144,77	152	25,0	25,0	25,0	—	—	92	124	1610	2,5	
TB 60 L 075	60	3W	GG	181,91	181,15	—	25,0	25,0	25,0	—	—	92	166	1610	3,0	
TB 72 L 075	72	3A	GG	218,30	217,53	—	25,0	25,0	25,0	—	—	92	202	1610	4,0	
TB 84 L 075	84	7A	GG	254,68	253,90	—	25,0	32,0	32,0	3,5	—	106	236	2012	5,2	
TB 96 L 075	96	7A	GG	291,06	290,30	—	25,0	32,0	32,0	3,5	—	106	270	2012	6,5	
TB 120 L 075	120	7A	GG	363,83	363,07	—	25,0	32,0	32,0	3,5	—	106	343	2012	7,6	

Taperbuchse Taper bush	1108	1610	2012
Bohrung d ₂ (mm) von ... bis ... Bore d ₂ (mm) from ... to ...	10-28	14-42	14-50
€/Stück each	auf Anfrage / on request		

St = Stahl Steel
GG = Grauguss Cast iron
Fertigungstechnische Änderungen vorbehalten.
We reserve the right to make technical changes.
Bohrungsdurchmesser d₂ siehe Seite 3-4.
Bore diameters d₂ see page 3-4.

Standard-Zahnscheiben für Taperbuchsen Timing belt pulleys for taper bushes

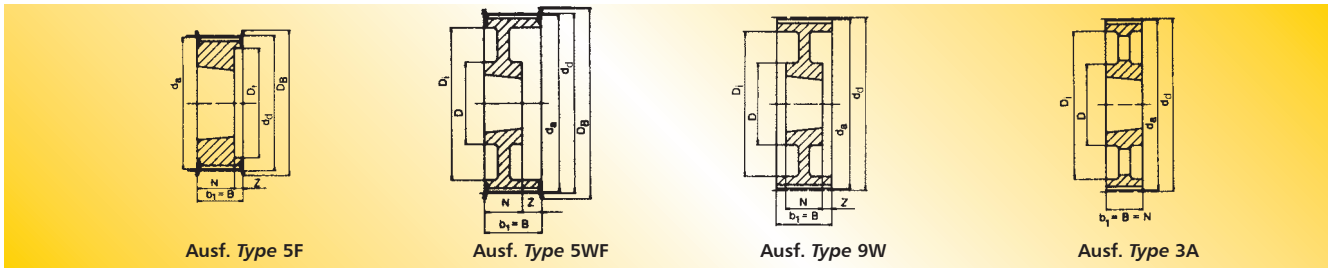

Type L – Teilung Pitch 9,525 mm für Riemenbreite for belt width 100

Bezeichnung Part No.	Anzahl der Zähne No. of teeth	Aus- führung Type	Mate- rial	d _d (mm)	d _s (mm)	D _B (mm)	b ₁ (mm)	B (mm)	N (mm)	V (mm)	Z (mm)	D (mm)	D _i (mm)	Taper- Buchse Taper bush	Gewicht ohne Buchse Weight without bush (= kg)	€ Stück ohne Buchse each without bush
TB 18 L 100	18	5F	St	54,57	53,81	60	31,0	31,0	22,0	—	9,0	—	38	1108	0,2	auf Anfrage on request
TB 19 L 100	19	5F	St	57,61	56,84	60	31,0	31,0	22,0	—	9,0	—	38	1108	0,3	
TB 20 L 100	20	5F	St	60,64	59,88	66	31,0	31,0	22,0	—	9,0	—	45	1108	0,4	
TB 21 L 100	21	5F	St	63,67	62,91	71	31,0	31,0	22,0	—	9,0	—	47	1108	0,4	
TB 22 L 100	22	5F	St	66,70	65,94	75	31,0	31,0	22,0	—	9,0	—	51	1108	0,4	
TB 23 L 100	23	5F	GG	69,73	68,97	79	32,0	32,0	22,0	—	10,0	—	54	1108	0,5	
TB 24 L 100	24	5F	GG	72,77	72,00	79	32,0	32,0	22,0	—	10,0	—	54	1108	0,6	
TB 25 L 100	25	5F	GG	75,80	75,04	83	32,0	32,0	22,0	—	10,0	—	56	1108	0,6	
TB 26 L 100	26	5F	GG	78,83	78,07	87	32,0	32,0	22,0	—	10,0	—	60	1108	0,7	
TB 27 L 100	27	5F	GG	81,86	81,10	87	32,0	32,0	22,0	—	10,0	—	62	1108	0,8	
TB 28 L 100	28	5F	GG	84,89	84,13	91	32,0	32,0	22,0	—	10,0	—	65	1108	0,8	
TB 30 L 100	30	5F	GG	90,96	90,20	97	32,0	32,0	25,0	—	7,0	—	71	1210	0,9	
TB 32 L 100	32	5F	GG	97,02	96,26	103	32,0	32,0	25,0	—	7,0	—	75	1210	1,0	
TB 36 L 100	36	5F	GG	109,15	108,39	115	32,0	32,0	25,0	—	7,0	—	89	1610	1,4	
TB 40 L 100	40	5F	GG	121,28	120,51	127	32,0	32,0	25,0	—	7,0	—	101	1610	1,7	
TB 48 L 100	48	5WF	GG	145,53	144,77	152	32,0	32,0	25,0	—	7,0	92	124	1610	2,7	
TB 60 L 100	60	9W	GG	181,91	181,15	—	32,0	32,0	25,0	—	3,5	92	166	1610	2,4	
TB 72 L 100	72	3A	GG	218,30	217,53	—	32,0	32,0	32,0	—	—	106	202	2012	4,4	
TB 84 L 100	84	3A	GG	254,68	253,90	—	32,0	32,0	32,0	—	—	106	236	2012	6,0	
TB 96 L 100	96	3A	GG	291,06	290,30	—	32,0	32,0	32,0	—	—	106	270	2012	7,1	
TB 120 L 100	120	3A	GG	363,83	363,07	—	32,0	32,0	32,0	—	—	106	343	2012	8,5	

Taperbuchse Taper bush	1108	1210	1610	2012
Bohrung d ₂ (mm) von ... bis ... Bore d ₂ (mm) from ... to ...	10-28	11-32	14-42	14-50
€/Stück each	auf Anfrage / on request			

St = Stahl Steel/
GG = Grauguss Cast iron
Fertigungstechnische Änderungen vorbehalten.
We reserve the right to make technical changes.
Bohrungsdurchmesser d₂ siehe Seite 3-4.
Bore diameters d₂ see page 3-4.

Standard-Zahnscheiben für Taperbuchsen

Timing belt pulleys for taper bushes

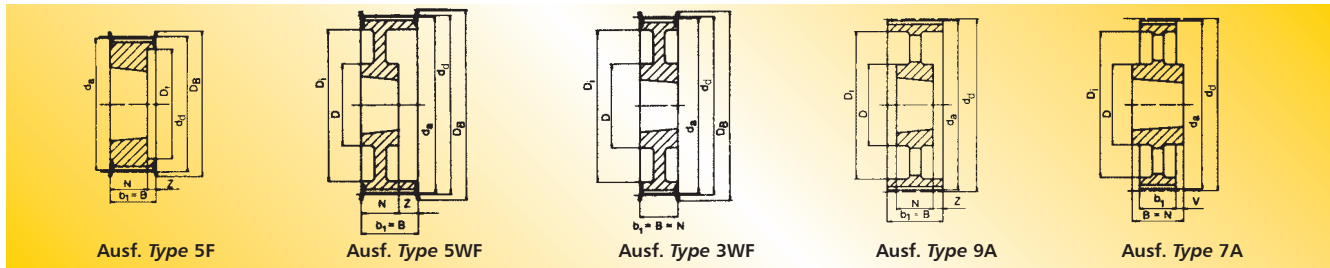

Type H – Teilung Pitch 12,7 mm für Riemenbreite for belt width 100

Bezeichnung Part No.	Anzahl der Zähne No. of teeth	Aus- führung Type	Material	d _d (mm)	d _s (mm)	D _B (mm)	b ₁ (mm)	B (mm)	N (mm)	V (mm)	Z (mm)	D (mm)	D _i (mm)	Taper- Buchse Taper bush	Gewicht ohne Buchse Weight without bush (≈ kg)	€ Stück ohne Buchse each without bush
TB 16 H 100	16	5F	St	64,68	63,31	71	31,0	31,0	22,0	—	9,0	—	45	1108	0,4	auf Anfrage on request
TB 18 H 100	18	5F	St	72,77	71,39	79	31,0	31,0	25,0	—	6,0	—	52	1210	0,5	
TB 19 H 100	19	5F	St	76,81	75,44	83	31,0	31,0	25,0	—	6,0	—	56	1210	0,6	
TB 20 H 100	20	5F	St	80,55	79,48	87	31,0	31,0	25,0	—	6,0	—	60	1210	0,7	
TB 21 H 100	21	5F	GG	84,89	83,52	91	32,0	32,0	25,0	—	7,0	—	63	1210	0,8	
TB 22 H 100	22	5F	GG	88,94	87,56	93	32,0	32,0	25,0	—	7,0	—	67	1210	0,9	
TB 23 H 100	23	5F	GG	92,98	91,61	97	32,0	32,0	25,0	—	7,0	—	71	1610	0,9	
TB 24 H 100	24	5F	GG	97,02	95,65	103	32,0	32,0	25,0	—	7,0	—	75	1610	1,0	
TB 25 H 100	25	5F	GG	101,06	99,69	106	32,0	32,0	25,0	—	7,0	—	79	1610	1,0	
TB 26 H 100	26	5F	GG	105,11	103,73	111	32,0	32,0	25,0	—	7,0	—	83	1610	1,2	
TB 27 H 100	27	5F	GG	109,15	107,78	115	32,0	32,0	25,0	—	7,0	—	87	1610	1,3	
TB 28 H 100	28	5F	GG	113,19	111,82	119	32,0	32,0	25,0	—	7,0	—	91	1610	1,5	
TB 30 H 100	30	5F	GG	121,28	119,90	127	32,0	32,0	25,0	—	7,0	—	99	1610	1,7	
TB 32 H 100	32	5WF	GG	129,36	127,99	135	32,0	32,0	25,0	—	7,0	92	108	1610	2,0	
TB 36 H 100	36	5WF	GG	145,53	144,16	152	32,0	32,0	25,0	—	7,0	92	124	1610	2,7	
TB 40 H 100	40	5WF	GG	161,70	160,33	168	32,0	32,0	25,0	—	7,0	92	140	1610	3,6	
TB 44 H 100	44	3WF	GG	177,87	176,50	184	32,0	32,0	32,0	—	—	106	153	2012	3,8	
TB 48 H 100	48	3WF	GG	194,04	192,67	200	32,0	32,0	32,0	—	—	106	169	2012	3,2	
TB 60 H 100	60	9A	GG	242,55	241,18	—	34,0	34,0	32,0	—	1,0	106	223	2012	4,8	
TB 72 H 100	72	9A	GG	291,06	289,69	—	34,0	34,0	32,0	—	1,0	106	270	2012	5,7	
TB 84 H 100	84	9A	GG	339,57	338,20	—	34,0	34,0	32,0	—	1,0	106	318	2012	6,8	
TB 96 H 100	96	7A	GG	388,08	386,71	—	34,0	45,0	45,0	5,5	—	119	366	2517	8,2	
TB 120 H 100	120	7A	GG	485,10	483,73	—	34,0	45,0	45,0	5,5	—	119	462	2517	12,1	

Type H – Teilung Pitch 12,7 mm für Riemenbreite for belt width 150

TB 18 H 150	18	5F	St	72,77	71,39	79	45,0	45,0	25,0	—	20,0	—	53	1210	0,6	auf Anfrage on request
TB 19 H 150	19	5F	St	76,81	75,44	83	45,0	45,0	25,0	—	20,0	—	56	1210	0,7	
TB 20 H 150	20	5F	St	80,55	79,48	87	45,0	45,0	25,0	—	20,0	—	60	1210	0,8	
TB 21 H 150	21	5F	GG	84,89	83,52	91	45,0	45,0	25,0	—	20,0	—	64	1210	1,0	
TB 22 H 150	22	5F	GG	88,94	87,56	93	45,0	45,0	25,0	—	20,0	—	68	1210	1,2	
TB 23 H 150	23	5F	GG	92,98	91,61	97	45,0	45,0	25,0	—	20,0	—	71	1610	1,3	
TB 24 H 150	24	5F	GG	97,02	95,65	103	45,0	45,0	25,0	—	20,0	—	74	1610	1,2	
TB 25 H 150	25	5F	GG	101,06	99,69	106	45,0	45,0	25,0	—	20,0	—	78	1610	1,2	
TB 26 H 150	26	5F	GG	105,11	103,73	111	45,0	45,0	25,0	—	20,0	—	82	1610	1,4	
TB 27 H 150	27	5F	GG	109,15	107,78	115	45,0	45,0	25,0	—	20,0	—	87	1610	1,6	
TB 28 H 150	28	5F	GG	113,19	111,82	119	45,0	45,0	25,0	—	20,0	—	91	1610	1,8	
TB 30 H 150	30	5F	GG	121,28	119,90	127	45,0	45,0	25,0	—	20,0	—	99	1610	2,0	
TB 32 H 150	32	5WF	GG	129,36	127,99	135	45,0	45,0	25,0	—	20,0	92	108	1610	2,3	
TB 36 H 150	36	5WF	GG	145,53	144,16	152	45,0	45,0	25,0	—	20,0	92	124	1610	3,1	
TB 40 H 150	40	5WF	GG	161,70	160,33	168	45,0	45,0	25,0	—	20,0	92	140	1610	4,0	
TB 44 H 150	44	5WF	GG	177,87	176,50	184	45,0	45,0	32,0	—	13,0	106	153	2012	4,4	
TB 48 H 150	48	5WF	GG	194,04	192,67	200	45,0	45,0	32,0	—	13,0	106	169	2012	4,8	
TB 60 H 150	60	9A	GG	242,55	241,18	—	46,0	46,0	32,0	—	7,0	106	223	2012	5,4	
TB 72 H 150	72	9A	GG	291,06	289,69	—	46,0	46,0	32,0	—	7,0	106	270	2012	6,5	
TB 84 H 150	84	9A	GG	339,57	338,20	—	46,0	46,0	32,0	—	7,0	106	320	2012	8,4	
TB 96 H 150	96	9A	GG	388,08	386,71	—	46,0	46,0	45,0	—	0,5	119	366	2517	11,0	
TB 120 H 150	120	9A	GG	485,10	483,73	—	46,0	46,0	45,0	—	0,5	119	462	2517	14,8	

Taperbuchse Taper bush	1108	1210	1610	2012	2517
Bohrung d ₂ (mm) von ... bis ... Bore d ₂ (mm) from ... to ...	10-28	11-32	14-42	14-50	16-60
€/Stück each	auf Anfrage / on request				

St = Stahl Steel – GG = Grauguss Cast iron
Fertigungstechnische Änderungen vorbehalten.
We reserve the right to make technical changes.

Bohrungsdurchmesser d₂ siehe Seite 3-4.
Bore diameters d₂ see page 3-4.

Standard-Zahnscheiben für Taperbuchsen Timing belt pulleys for taper bushes

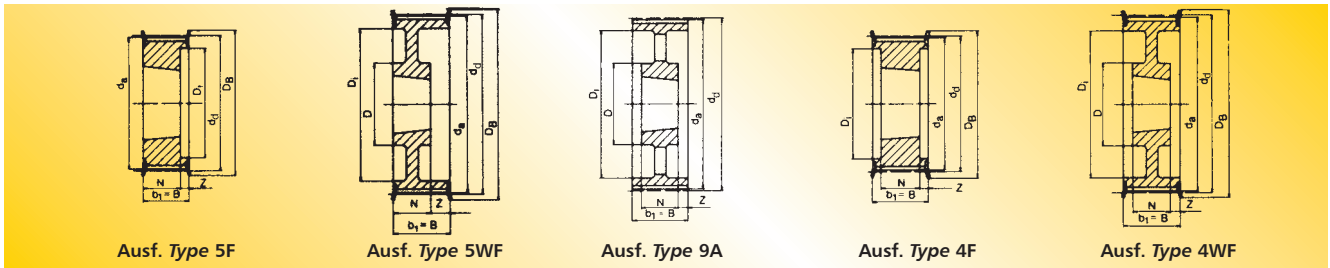

Type H – Teilung Pitch 12,7 mm für Riemenbreite for belt width 200

Bezeichnung Part No.	Anzahl der Zähne No. of teeth	Aus- führung Type	Material	d _d (mm)	d _s (mm)	D _B (mm)	b ₁ (mm)	B (mm)	N (mm)	V (mm)	Z (mm)	D (mm)	D _i (mm)	Taper- Buchse Taper bush	Gewicht ohne Buchse Weight without bush (= kg)	€ Stück ohne Buchse each without bush
TB 18 H 200	18	5F	St	72,77	71,39	79	58,0	58,0	25,0	—	33,0	—	52	1210	0,8	auf Anfrage on request
TB 19 H 200	19	5F	St	76,81	75,44	83	58,0	58,0	25,0	—	33,0	—	56	1610	0,9	
TB 20 H 200	20	5F	St	80,55	79,48	87	58,0	58,0	25,0	—	33,0	—	60	1610	1,0	
TB 21 H 200	21	5F	GG	84,89	83,52	91	58,0	58,0	25,0	—	33,0	—	64	1610	1,7	
TB 22 H 200	22	5F	GG	88,94	87,56	93	58,0	58,0	25,0	—	33,0	—	68	1610	1,5	
TB 23 H 200	23	5F	GG	92,98	91,61	97	58,0	58,0	25,0	—	33,0	—	71	1610	1,8	
TB 24 H 200	24	5F	GG	97,02	95,65	103	58,0	58,0	25,0	—	33,0	—	74	1610	1,5	
TB 25 H 200	25	5F	GG	101,06	99,69	106	58,0	58,0	25,0	—	33,0	—	78	1610	1,5	
TB 26 H 200	26	5F	GG	105,11	103,73	111	58,0	58,0	25,0	—	33,0	—	82	1610	1,8	
TB 27 H 200	27	5F	GG	109,15	107,78	115	58,0	58,0	25,0	—	33,0	—	87	1610	1,9	
TB 28 H 200	28	5F	GG	113,19	111,82	119	58,0	58,0	25,0	—	33,0	—	91	1610	1,9	
TB 30 H 200	30	5F	GG	121,28	119,90	127	58,0	58,0	25,0	—	33,0	—	99	1610	2,3	
TB 32 H 200	32	5F	GG	129,36	127,99	135	58,0	58,0	32,0	—	26,0	—	107	2012	3,0	
TB 36 H 200	36	5WF	GG	145,53	144,16	152	58,0	58,0	32,0	—	26,0	102	124	2012	3,0	
TB 40 H 200	40	5WF	GG	161,70	160,33	168	58,0	58,0	32,0	—	26,0	106	140	2012	3,6	
TB 44 H 200	44	5WF	GG	177,87	176,50	184	58,0	58,0	32,0	—	26,0	106	153	2012	4,5	
TB 48 H 200	48	5WF	GG	194,04	192,67	200	58,0	58,0	45,0	—	13,0	119	169	2517	4,6	
TB 60 H 200	60	9A	GG	242,55	241,18	—	60,0	60,0	45,0	—	7,5	119	223	2517	7,0	
TB 72 H 200	72	9A	GG	291,06	289,69	—	60,0	60,0	45,0	—	7,5	119	270	2517	8,0	
TB 84 H 200	84	9A	GG	339,57	338,20	—	60,0	60,0	45,0	—	7,5	119	320	2517	9,0	
TB 96 H 200	96	9A	GG	388,08	386,71	—	60,0	60,0	45,0	—	7,5	119	366	2517	11,5	
TB 120 H 200	120	9A	GG	485,10	483,73	—	60,0	60,0	45,0	—	7,5	119	462	2517	15,4	

Type H – Teilung Pitch 12,7 mm für Riemenbreite for belt width 300

TB 20 H 300	20	4F	St	80,55	79,48	87	84,0	84,0	38,0	—	23,0	—	65	1615	1,5	auf Anfrage on request
TB 21 H 300	21	4F	GG	84,89	83,52	91	84,0	84,0	38,0	—	23,0	—	66	1615	1,2	
TB 22 H 300	22	4F	GG	88,94	87,56	93	84,0	84,0	38,0	—	23,0	—	67	1615	1,6	
TB 23 H 300	23	4F	GG	92,98	91,61	97	84,0	84,0	38,0	—	23,0	—	71	1615	1,8	
TB 24 H 300	24	4F	GG	97,02	95,65	103	84,0	84,0	38,0	—	23,0	—	75	1615	2,1	
TB 25 H 300	25	4F	GG	101,06	99,69	106	84,0	84,0	38,0	—	23,0	—	79	1615	2,0	
TB 26 H 300	26	4F	GG	105,11	103,73	111	84,0	84,0	38,0	—	23,0	—	83	1615	2,7	
TB 27 H 300	27	4F	GG	109,15	107,78	115	84,0	84,0	32,0	—	26,0	—	87	2012	3,0	
TB 28 H 300	28	4F	GG	113,19	111,82	119	84,0	84,0	32,0	—	26,0	—	91	2012	2,4	
TB 30 H 300	30	4F	GG	121,28	119,90	127	84,0	84,0	32,0	—	26,0	—	99	2012	2,9	
TB 32 H 300	32	4F	GG	129,36	127,99	135	84,0	84,0	45,0	—	19,5	—	107	2517	3,3	
TB 36 H 300	36	4F	GG	145,53	144,16	152	84,0	84,0	45,0	—	19,5	—	124	2517	4,5	
TB 40 H 300	40	4F	GG	161,70	160,33	168	84,0	84,0	45,0	—	19,5	—	137	2517	6,0	
TB 44 H 300	44	4WF	GG	177,87	176,50	184	86,0	86,0	45,0	—	20,5	119	153	2517	6,6	
TB 48 H 300	48	4WF	GG	194,04	192,67	200	86,0	86,0	45,0	—	20,5	119	169	2517	7,6	
TB 60 H 300	60	9A	GG	242,55	241,18	—	86,0	86,0	45,0	—	20,5	119	223	2517	8,4	
TB 72 H 300	72	9A	GG	291,06	289,69	—	86,0	86,0	45,0	—	20,5	119	270	2517	10,4	
TB 84 H 300	84	9A	GG	339,57	338,20	—	86,0	86,0	45,0	—	20,5	119	320	2517	12,5	
TB 96 H 300	96	9A	GG	388,08	386,71	—	86,0	86,0	76,0	—	5,0	150	362	3030	14,2	
TB 120 H 300	120	9A	GG	485,10	483,73	—	86,0	86,0	76,0	—	5,0	150	460	3030	18,8	

Taperbuchse Taper bush	1210	1610	1615	2012	2517	3030
Bohrung d ₂ (mm) von ... bis ... Bore d ₂ (mm) from ... to ...	11-32	14-42	14-42	14-50	16-60	35-75
€/Stück each	auf Anfrage / on request					

St = Stahl Steel – GG = Grauguss Cast iron
Fertigungstechnische Änderungen vorbehalten.
We reserve the right to make technical changes.

Bohrungsdurchmesser d₂ siehe Seite 3-4.
Bore diameters d₂ see page 3-4.

Standard-Zahnscheiben für Taperbuchsen

Timing belt pulleys for taper bushes

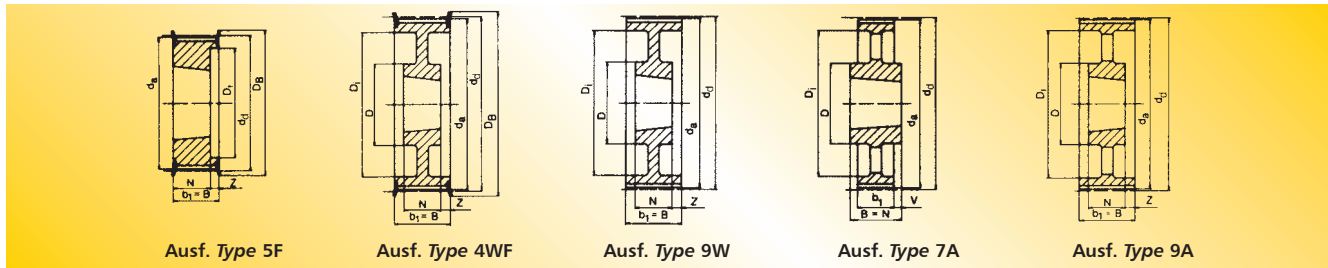

Type XH – Teilung Pitch 22,225 mm für Riemenbreite for belt width 200

Bezeichnung Part No.	Anzahl der Zähne No. of teeth	Aus- führung Type	Material	d _d (mm)	d _s (mm)	D _B (mm)	b ₁ (mm)	B (mm)	N (mm)	V (mm)	Z (mm)	D (mm)	D _i (mm)	Taper- Buchse Taper bush	Gewicht ohne Buchse Weight without bush (≈ kg)	€ Stück ohne Buchse each without bush
TB 18 XH 200	18	5F	GG	127,34	124,55	138	64	64	45	—	20,0	—	95	2517	2,6	auf Anfrage on request
TB 20 XH 200	20	5F	GG	141,49	138,69	154	64	64	45	—	20,0	—	110	2517	3,6	
TB 22 XH 200	22	5F	GG	155,64	152,84	168	64	64	45	—	20,0	—	120	2517	4,8	
TB 24 XH 200	24	5F	GG	169,79	166,69	183	64	64	45	—	20,0	—	135	2517	6,1	
TB 26 XH 200	26	5F	GG	183,94	181,14	198	64	64	45	—	20,0	—	150	2517	7,4	
TB 28 XH 200	28	4WF	GG	198,08	195,29	211	64	64	45	—	10,0	120	165	2517	9,0	
TB 30 XH 200	30	4WF	GG	212,23	209,44	226	64	64	45	—	10,0	120	180	2517	8,6	
TB 32 XH 200	32	4WF	GG	226,38	223,59	240	64	64	45	—	10,0	120	195	2517	9,8	
TB 40 XH 200	40	4WF	GG	282,98	280,18	296	64	64	51	—	6,5	160	245	3020	13,3	
TB 48 XH 200	48	9W	GG	339,57	336,78	—	64	64	51	—	6,5	160	300	3020	19,0	

Type XH – Teilung Pitch 22,225 mm für Riemenbreite for belt width 300

TB 18 XH 300	18	5F	GG	127,34	124,55	138	90	90	45	—	45,0	—	95	2517	3,7	auf Anfrage on request
TB 20 XH 300	20	5F	GG	141,49	138,69	154	90	90	45	—	45,0	—	110	2517	4,7	
TB 22 XH 300	22	5F	GG	155,64	152,84	168	90	90	45	—	45,0	—	120	2517	6,0	
TB 24 XH 300	24	5F	GG	169,79	166,69	183	90	90	45	—	45,0	—	135	2517	7,6	
TB 26 XH 300	26	5F	GG	183,94	181,14	198	90	90	45	—	45,0	—	150	2517	9,8	
TB 28 XH 300	28	5F	GG	198,08	195,29	211	90	90	51	—	39,0	—	165	3020	11,6	
TB 30 XH 300	30	5F	GG	212,23	209,44	226	90	90	51	—	39,0	—	180	3020	11,9	
TB 32 XH 300	32	5F	GG	226,38	223,59	240	90	90	51	—	39,0	—	195	3020	13,8	
TB 40 XH 300	40	4WF	GG	282,98	280,18	296	90	90	51	—	19,5	160	245	3020	19,5	
TB 48 XH 300	48	9W	GG	339,57	336,78	—	90	90	51	—	19,5	160	300	3020	27,0	

Taperbuchse Taper bush	2517	3020	3535	4040
Bohrung d ₂ (mm) von ... bis ... Bore d ₂ (mm) from ... to ...	16-60	25-75	35-90	40-100
€/Stück each	auf Anfrage / on request			

GG = Grauguss Cast iron
Fertigungstechnische Änderungen vorbehalten.
We reserve the right to make technical changes.

Bohrungsdurchmesser d₂ siehe Seite 3-4.
Bore diameters d₂ see page 3-4.

Standard-Zahnscheiben für Taperbuchsen Timing belt pulleys for taper bushes

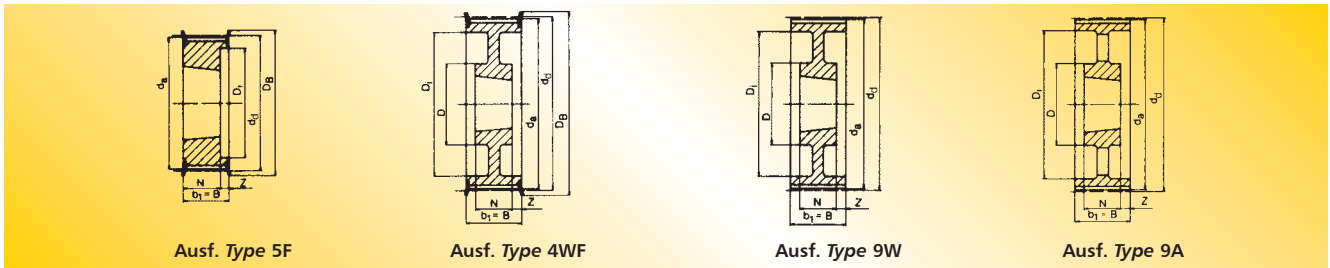

Type XH – Teilung Pitch 22,225 mm für Riemenbreite for belt width 400

Bezeichnung Part No.	Anzahl der Zähne No. of teeth	Aus- führung Type	Mate- rial	d_d (mm)	d_s (mm)	D_B (mm)	b_1 (mm)	B (mm)	N (mm)	V (mm)	Z (mm)	D (mm)	D_1 (mm)	Taper- Buchse Taper bush	Gewicht ohne Buchse Weight without bush (= kg)	€ Stück ohne Buchse each without bush
TB 20 XH 400	20	5F	GG	141,49	138,69	154	119	119	45	—	74,0	—	110	2517	6,0	auf Anfrage on request
TB 22 XH 400	22	5F	GG	155,64	152,84	168	119	119	45	—	74,0	—	120	2517	7,2	
TB 24 XH 400	24	5F	GG	169,79	166,69	183	119	119	51	—	68,0	—	135	3020	8,4	
TB 26 XH 400	26	5F	GG	183,94	181,14	198	119	119	51	—	68,0	—	150	3020	10,3	
TB 28 XH 400	28	5F	GG	198,08	195,29	211	119	119	51	—	68,0	—	165	3020	12,3	
TB 30 XH 400	30	5F	GG	212,23	209,44	226	119	119	51	—	68,0	—	180	3020	14,3	
TB 32 XH 400	32	5F	GG	226,38	223,59	240	119	119	51	—	68,0	—	195	3020	19,9	
TB 40 XH 400	40	4WF	GG	282,98	280,18	296	119	119	89	—	15,0	190	245	3535	24,6	
TB 48 XH 400	48	9W	GG	339,57	336,78	—	119	119	89	—	15,0	190	300	3535	30,0	

Taperbuchse Taper bush	2517	3020	3535	4040
Bohrung d_2 (mm) von ... bis ... Bore d_2 (mm) from ... to ...	16-60	25-75	35-90	40-100
€/Stück each	auf Anfrage / on request			

GG = Grauguss Cast iron
Fertigungstechnische Änderungen vorbehalten.
We reserve the right to make technical changes.

Bohrungsdurchmesser d_2 siehe Seite 3-4.
Bore diameters d_2 see page 3-4.

HTD®-Zahnscheiben für zylindrische Bohrung HTD® pulleys for plain boring

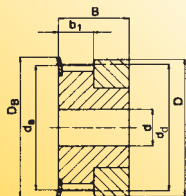

Ausf. Type 1F

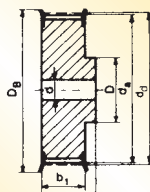

Ausf. Type 6F

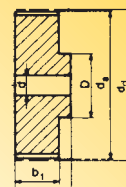

Ausf. Type 6

Type 3M – Teilung Pitch 3 mm für Riemenbreite for belt width 6 mm keine Lagerware non stock items

Bezeichnung Part No.	Anzahl der Zähne No. of teeth	Aus- führung Type	Material	d _d (mm)	d _s (mm)	D _B (mm)	b ₁ (mm)	B (mm)	D (mm)	Vor- bohrung Pilot bore d (mm)	Fertig- bohrung Finished bore d _{max} (mm)	Gewicht Weight (≈ kg)	€ Stück each
10-3M-6	10	1F	Al	9,55	8,79	13,0	7,2	14,5	13,0	—	3		auf Anfrage on request
12-3M-6	12	1F	Al	11,46	10,70	15,0	7,2	14,5	15,0	—	5		
14-3M-6	14	1F	Al	13,37	12,61	16,0	7,2	14,5	16,0	—	6		
15-3M-6	15	1F	Al	14,32	13,56	17,5	7,2	14,5	17,5	—	6		
16-3M-6	16	6F	Al	15,28	14,52	18,0	9,8	17,5	10,0	4	7		
18-3M-6	18	6F	Al	17,19	16,43	19,5	9,8	17,5	11,0	6	8		
20-3M-6	20	6F	Al	19,10	18,34	23,0	9,8	17,5	13,0	6	9		
21-3M-6	21	6F	Al	20,05	19,29	25,0	9,8	17,5	14,0	6	9		
22-3M-6	22	6F	Al	21,01	20,25	25,0	9,8	17,5	14,0	6	9		
24-3M-6	24	6F	Al	22,92	22,16	25,0	9,8	17,5	14,0	6	9		
26-3M-6	26	6F	Al	24,83	24,07	28,0	9,8	17,5	16,0	6	11		
28-3M-6	28	6F	Al	26,74	25,98	32,0	9,8	17,5	18,0	6	12		
30-3M-6	30	6F	Al	28,65	27,89	32,0	9,8	17,5	20,0	6	14		
32-3M-6	32	6F	Al	30,56	29,80	36,0	9,8	17,5	22,0	6	15		
36-3M-6	36	6F	Al	34,38	33,62	38,0	10,3	18,0	26,0	6	16		
40-3M-6	40	6F	Al	38,20	37,44	42,0	10,3	18,0	28,0	6	18		
44-3M-6	44	6F	Al	42,02	41,26	48,0	10,3	18,0	33,0	6	20		
48-3M-6	48	6	Al	45,84	45,08	—	10,3	18,6	33,0	8	20		
60-3M-6	60	6	Al	57,30	56,54	—	10,3	18,6	33,0	8	20		
72-3M-6	72	6	Al	68,75	67,99	—	10,3	18,6	33,0	8	20		

Type 3M – Teilung Pitch 3 mm für Riemenbreite for belt width 9 mm

10-3M-9	10	1F	Al	9,55	8,79	13,0	10,2	17,5	13,0	—	3	0,004	auf Anfrage on request
12-3M-9	12	1F	Al	11,46	10,70	15,0	10,2	17,5	15,0	—	5	0,006	
14-3M-9	14	1F	Al	13,37	12,61	16,0	10,2	17,5	16,0	—	6	0,007	
15-3M-9	15	1F	Al	14,32	13,56	17,5	10,2	17,5	17,5	—	6	0,008	
16-3M-9	16	6F	Al	15,28	14,52	18,0	12,8	20,6	10,0	4	7	0,007	
18-3M-9	18	6F	Al	17,19	16,43	19,5	12,8	20,6	11,0	6	8	0,008	
20-3M-9	20	6F	Al	19,10	18,34	23,0	12,8	20,6	13,0	6	9	0,010	
21-3M-9	21	6F	Al	20,05	19,29	25,0	12,8	20,6	14,0	6	9	0,013	
22-3M-9	22	6F	Al	21,01	20,25	25,0	12,8	20,6	14,0	6	9	0,014	
24-3M-9	24	6F	Al	22,92	22,16	25,0	12,8	20,6	14,0	6	9	0,016	
26-3M-9	26	6F	Al	24,83	24,07	28,0	12,8	20,6	16,0	6	11	0,018	
28-3M-9	28	6F	Al	26,74	25,98	32,0	12,8	20,6	18,0	6	12	0,024	
30-3M-9	30	6F	Al	28,65	27,89	32,0	12,8	20,6	20,0	6	14	0,028	
32-3M-9	32	6F	Al	30,56	29,80	36,0	12,8	20,6	22,0	6	15	0,032	
36-3M-9	36	6F	Al	34,38	33,62	38,0	13,4	22,2	26,0	6	16	0,045	
40-3M-9	40	6F	Al	38,20	37,44	42,0	13,4	22,2	28,0	6	18	0,055	
44-3M-9	44	6F	Al	42,02	41,26	48,0	13,4	22,2	33,0	6	20	0,074	
48-3M-9	48	6	Al	45,84	45,08	—	13,4	22,2	33,0	8	20	0,074	
60-3M-9	60	6	Al	57,30	56,54	—	13,4	22,2	33,0	8	20	0,106	
72-3M-9	72	6	Al	68,75	67,99	—	13,4	22,2	33,0	8	20	0,145	

Al = Aluminium

Fertigungstechnische Änderungen vorbehalten. We reserve the right to make technical changes.

HTD[®]-Zahnscheiben für zylindrische Bohrung HTD[®] pulleys for plain boring

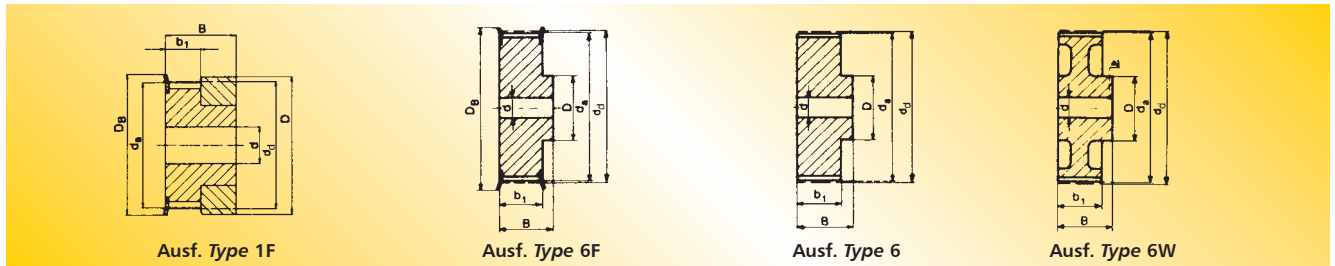

Ausf. Type 1F

Ausf. Type 6F

Ausf. Type 6

Ausf. Type 6W

Type 3M – Teilung Pitch 3 mm für Riemenbreite for belt width 15 mm

Bezeichnung Part No.	Anzahl der Zähne No. of teeth	Ausführung Type	Material	d _d (mm)	d _s (mm)	D _B (mm)	b ₁ (mm)	B (mm)	D (mm)	Vorbohrung Pilot bore d (mm)	Fertigbohrung Finished bore d _{max} (mm)	Gewicht Weight (≈ kg)	€ Stück each
10-3M-15	10	1F	Al	9,55	8,79	13,0	17,0	26	13,0	—	3	0,006	auf Anfrage on request
12-3M-15	12	1F	Al	11,46	10,70	15,0	17,0	26	15,0	—	5	0,008	
14-3M-15	14	1F	Al	13,37	12,61	16,0	17,0	26	16,0	—	6	0,010	
15-3M-15	15	1F	Al	14,32	13,56	17,5	17,0	26	17,5	—	6	0,012	
16-3M-15	16	6F	Al	15,28	14,52	18,0	19,5	26	10,0	4	7	0,010	
18-3M-15	18	6F	Al	17,19	16,43	19,5	19,5	26	11,0	6	8	0,012	
20-3M-15	20	6F	Al	19,10	18,34	23,0	19,5	26	13,0	6	9	0,014	
21-3M-15	21	6F	Al	20,05	19,29	25,0	19,5	26	14,0	6	9	0,016	
22-3M-15	22	6F	Al	21,01	20,25	25,0	19,5	26	14,0	6	9	0,018	
24-3M-15	24	6F	Al	22,92	22,16	25,0	19,5	26	14,0	6	9	0,020	
26-3M-15	26	6F	Al	24,83	24,07	28,0	19,5	26	16,0	6	11	0,027	
28-3M-15	28	6F	Al	26,74	25,98	32,0	19,5	26	18,0	6	12	0,030	
30-3M-15	30	6F	Al	28,65	27,89	32,0	19,5	26	20,0	6	14	0,035	
32-3M-15	32	6F	Al	30,56	29,80	36,0	19,5	26	22,0	6	15	0,042	
36-3M-15	36	6F	Al	34,38	33,62	38,0	20,0	30	26,0	6	16	0,060	
40-3M-15	40	6F	Al	38,20	37,44	42,0	20,0	30	28,0	6	18	0,075	
44-3M-15	44	6F	Al	42,02	41,26	48,0	20,0	30	33,0	6	20	0,100	
48-3M-15	48	6	Al	45,84	45,08	—	20,0	30	33,0	8	20	0,103	
60-3M-15	60	6	Al	57,30	56,54	—	20,0	30	33,0	8	20	0,150	
72-3M-15	72	6	Al	68,75	67,99	—	20,0	30	33,0	8	20	0,212	

Type 5M – Teilung Pitch 5 mm für Riemenbreite for belt width 9 mm

12-5M-9	12	6F	St	19,10	17,96	23	14,5	20,0	13,0	4	7	0,028	auf Anfrage on request
14-5M-9	14	6F	St	22,28	21,14	25	14,5	20,0	14,0	6	8	0,034	
15-5M-9	15	6F	St	23,87	22,73	28	14,5	20,0	16,0	6	10	0,042	
16-5M-9	16	6F	St	25,46	24,32	28	14,5	20,0	16,5	6	10	0,050	
18-5M-9	18	6F	St	28,65	27,51	32	14,5	20,0	20,0	6	12	0,070	
20-5M-9	20	6F	St	31,83	30,69	36	14,5	22,5	23,0	6	14	0,094	
21-5M-9	21	6F	St	33,42	32,28	38	14,5	22,5	24,0	6	14	0,110	
22-5M-9	22	6F	St	35,01	33,87	38	14,5	22,5	25,5	6	14	0,118	
24-5M-9	24	6F	St	38,20	37,06	42	14,5	22,5	27,0	6	16	0,145	
26-5M-9	26	6F	St	41,38	40,24	44	14,5	22,5	30,0	6	18	0,170	
28-5M-9	28	6F	St	44,56	43,42	48	14,5	22,5	30,5	6	18	0,200	
30-5M-9	30	6F	St	47,75	46,61	51	14,5	22,5	35,0	6	20	0,236	
32-5M-9	32	6F	St	50,93	49,79	54	14,5	22,5	38,0	8	22	0,270	
36-5M-9	36	6F	St	57,30	56,16	60	14,5	22,5	38,0	8	22	0,324	
40-5M-9	40	6F	St	63,66	62,52	71	14,5	22,5	38,0	8	22	0,400	
44-5M-9	44	6W	Al	70,03	68,89	—	14,5	25,5	38,0	8	22	0,170	
48-5M-9	48	6W	Al	76,39	75,25	—	14,5	25,5	45,0	8	25	0,182	
60-5M-9	60	6W	Al	95,49	94,35	—	14,5	25,5	45,0	8	25	0,230	
72-5M-9	72	6W	Al	114,59	113,45	—	14,5	25,5	45,0	8	25	0,270	

HTD®-Zahnscheiben für zylindrische Bohrung HTD® pulleys for plain boring

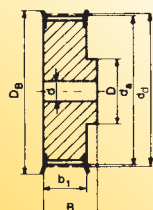

Ausf. Type 6F

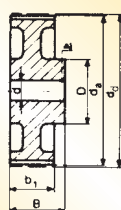

Ausf. Type 6W

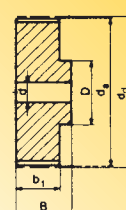

Ausf. Type 6

Type 5M – Teilung Pitch 5 mm für Riemenbreite for belt width 15 mm

Bezeichnung Part No.	Anzahl der Zähne No. of teeth	Aus- führung Type	Material	d _d (mm)	d _a (mm)	D _B (mm)	b ₁ (mm)	B (mm)	D (mm)	Vor- bohrung Pilot bore d (mm)	Fertig- bohrung Finished bore d _{max} (mm)	Gewicht Weight (≈ kg)	€ Stück each
12-5M-15	12	6F	St	19,10	17,96	25	20,5	26	13,0	4	7	0,034	auf Anfrage on request
14-5M-15	14	6F	St	22,28	21,14	25	20,5	26	14,0	6	8	0,046	
15-5M-15	15	6F	St	23,87	22,73	28	20,5	26	16,0	6	10	0,056	
16-5M-15	16	6F	St	25,46	24,32	28	20,5	26	16,5	6	10	0,064	
18-5M-15	18	6F	St	28,65	27,51	32	20,5	26	20,0	6	12	0,086	
20-5M-15	20	6F	St	31,83	30,69	36	20,5	26	23,0	6	14	0,112	
21-5M-15	21	6F	St	33,42	32,28	38	20,5	26	24,0	6	14	0,130	
22-5M-15	22	6F	St	35,01	33,87	38	20,5	26	25,5	6	14	0,140	
24-5M-15	24	6F	St	38,20	37,06	42	20,5	28	27,0	6	16	0,180	
26-5M-15	26	6F	St	41,38	40,24	44	20,5	28	30,0	6	18	0,220	
28-5M-15	28	6F	St	44,56	43,42	48	20,5	28	30,5	6	18	0,250	
30-5M-15	30	6F	St	47,75	46,61	51	20,5	28	35,0	6	20	0,300	
32-5M-15	32	6F	St	50,93	49,79	54	20,5	28	38,0	8	22	0,350	
36-5M-15	36	6F	St	57,30	56,16	60	20,5	28	38,0	8	22	0,426	
40-5M-15	40	6F	St	63,66	62,52	71	20,5	28	38,0	8	22	0,520	
44-5M-15	44	6W	Al	70,03	68,89	—	20,5	30	38,0	8	22	0,225	
48-5M-15	48	6W	Al	76,39	75,25	—	20,5	30	38,0	8	25	0,187	
60-5M-15	60	6W	Al	95,49	94,35	—	20,5	30	50,0	8	25	0,305	
72-5M-15	72	6W	Al	114,59	113,45	—	20,5	30	50,0	8	25	0,375	

Type 5M – Teilung Pitch 5 mm für Riemenbreite for belt width 25 mm

12-5M-25	12	6F	St	19,10	17,96	25	30	36	13,0	4	7	0,050	auf Anfrage on request
14-5M-25	14	6F	St	22,28	21,14	25	30	36	14,0	6	8	0,070	
15-5M-25	15	6F	St	23,87	22,73	28	30	36	16,0	6	10	0,080	
16-5M-25	16	6F	St	25,46	24,32	28	30	36	16,5	6	10	0,100	
18-5M-25	18	6F	St	28,65	27,51	32	30	36	20,0	6	12	0,120	
20-5M-25	20	6F	St	31,83	30,69	36	30	36	23,0	6	14	0,160	
21-5M-25	21	6F	St	33,42	32,28	38	30	38	24,0	6	14	0,190	
22-5M-25	22	6F	St	35,01	33,87	38	30	38	25,5	6	14	0,210	
24-5M-25	24	6F	St	38,20	37,06	42	30	38	27,0	6	16	0,250	
26-5M-25	26	6F	St	41,38	40,24	44	30	38	30,0	6	18	0,300	
28-5M-25	28	6F	St	44,56	43,42	48	30	38	30,5	6	18	0,350	
30-5M-25	30	6F	St	47,75	46,61	51	30	38	35,0	6	20	0,420	
32-5M-25	32	6F	St	50,93	49,79	54	30	38	38,0	8	22	0,480	
36-5M-25	36	6F	St	57,30	56,16	60	30	38	38,0	8	22	0,590	
40-5M-25	40	6F	St	63,66	62,52	71	30	38	38,0	8	22	0,740	
44-5M-25	44	6W	Al	70,03	68,89	—	30	40	38,0	8	22	0,320	
48-5M-25	48	6W	Al	76,39	75,25	—	30	40	38,0	8	25	0,275	
60-5M-25	60	6W	Al	95,49	94,35	—	30	40	50,0	8	25	0,435	
72-5M-25	72	6W	Al	114,59	113,45	—	30	40	50,0	8	25	0,525	

St = Stahl Steel Al = Aluminium

Fertigungstechnische Änderungen vorbehalten. We reserve the right to make technical changes.

HTD®-Zahnscheiben für zylindrische Bohrung HTD® pulleys for plain boring

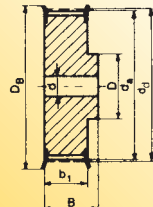

Ausf. Type 6F

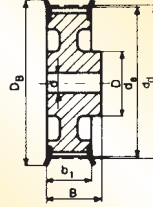

Ausf. Type 6WF

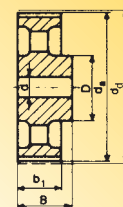

Ausf. Type 6A

Type 8M – Teilung Pitch 8 mm für Riemenbreite for belt width 20 mm

Bezeichnung Part No.	Anzahl der Zähne No. of teeth	Aus- führung Type	Material	d _d (mm)	d _s (mm)	D _B (mm)	b ₁ (mm)	B (mm)	D (mm)	D ₁ (mm)	Vor- bohrung Pilot bore d (mm)	Fertig- bohrung Finished bore d _{max} (mm)	Gewicht Weight (≈ kg)	€ Stück each
22-8M-20	22	6F	St	56,02	54,65	60,0	28	38	43	—	12	30	0,54	auf Anfrage on request
24-8M-20	24	6F	St	61,12	59,75	66,0	28	38	45	—	12	30	0,65	
26-8M-20	26	6F	St	66,21	64,84	71,0	28	38	50	—	12	35	0,80	
28-8M-20	28	6F	St	71,30	69,93	75,0	28	38	50	—	15	35	0,87	
30-8M-20	30	6F	St	76,39	75,02	83,0	28	38	55	—	15	35	1,02	
32-8M-20	32	6F	St	81,49	80,12	87,0	28	38	60	—	15	40	1,20	
34-8M-20	34	6F	St	86,58	85,22	91,0	28	38	70	—	15	45	1,40	
36-8M-20	36	6F	St	91,67	90,30	98,5	28	38	70	—	15	45	1,55	
38-8M-20	38	6F	St	96,77	95,39	103,0	28	38	75	—	15	45	1,65	
40-8M-20	40	6F	GG	101,86	100,49	106,0	28	38	75	—	15	45	1,80	
44-8M-20	44	6F	GG	112,05	110,67	119,0	28	38	75	—	15	45	2,10	
48-8M-20	48	6F	GG	122,23	120,86	127,0	28	38	75	—	15	45	2,44	
56-8M-20	56	6WF	GG	142,60	141,23	148,0	28	38	80	117	15	45	2,60	
64-8M-20	64	6WF	GG	162,97	161,60	168,0	28	38	80	137	15	45	2,90	
72-8M-20	72	6WF	GG	183,35	181,97	192,0	28	38	80	158	15	45	3,10	
80-8M-20	80	6A	GG	203,72	202,35	—	28	38	90	180	15	50	3,80	
90-8M-20	90	6A	GG	229,18	227,81	—	28	38	90	204	15	50	4,20	
112-8M-20	112	6A	GG	285,21	283,83	—	28	38	90	260	18	50	5,20	
144-8M-20	144	6A	GG	366,69	365,32	—	28	38	90	341	20	50	7,50	
168-8M-20	168	6A	GG	427,81	426,44	—	28	38	100	402	20	55	10,00	
192-8M-20	192	6A	GG	488,92	487,55	—	28	38	100	463	20	55	14,40	

Type 8M – Teilung Pitch 8 mm für Riemenbreite for belt width 30 mm

22-8M-30	22	6F	St	56,02	54,65	60,0	38	48	43	—	12	30	0,69	auf Anfrage on request
24-8M-30	24	6F	St	61,12	59,75	66,0	38	48	45	—	12	30	0,84	
26-8M-30	26	6F	St	66,21	64,84	71,0	38	48	50	—	12	35	1,00	
28-8M-30	28	6F	St	71,30	69,93	75,0	38	48	50	—	15	35	1,12	
30-8M-30	30	6F	St	76,39	75,02	83,0	38	48	55	—	15	35	1,32	
32-8M-30	32	6F	St	81,49	80,12	87,0	38	48	60	—	15	40	1,50	
34-8M-30	34	6F	St	86,58	85,22	91,0	38	48	70	—	15	45	1,80	
36-8M-30	36	6F	St	91,67	90,30	98,5	38	48	70	—	15	45	1,99	
38-8M-30	38	6F	St	96,77	95,39	103,0	38	48	75	—	15	45	2,27	
40-8M-30	40	6F	GG	101,86	100,49	106,0	38	48	75	—	15	45	2,40	
44-8M-30	44	6F	GG	112,05	110,67	119,0	38	48	75	—	15	45	2,80	
48-8M-30	48	6F	GG	122,23	120,86	127,0	38	48	75	—	15	45	3,20	
56-8M-30	56	6WF	GG	142,60	141,23	148,0	38	48	90	117	15	50	3,60	
64-8M-30	64	6WF	GG	162,97	161,60	168,0	38	48	90	137	15	50	4,30	
72-8M-30	72	6WF	GG	183,35	181,97	192,0	38	48	95	158	15	50	4,80	
80-8M-30	80	6A	GG	203,72	202,35	—	38	48	100	180	15	55	5,10	
90-8M-30	90	6A	GG	229,18	227,81	—	38	48	100	204	15	55	5,70	
112-8M-30	112	6A	GG	285,21	283,83	—	38	48	100	260	18	55	6,80	
144-8M-30	144	6A	GG	366,69	365,32	—	38	48	100	341	20	55	9,30	
168-8M-30	168	6A	GG	427,81	426,44	—	38	48	100	402	20	55	11,40	
192-8M-30	192	6A	GG	488,92	487,55	—	38	48	100	463	20	55	16,00	

HTD®-Zahnscheiben für zylindrische Bohrung HTD® pulleys for plain boring

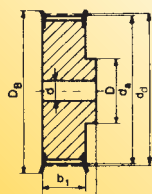

Ausf. Type 6F

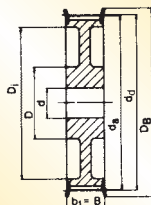

Ausf. Type 10WF

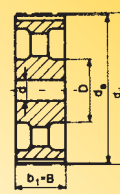

Ausf. Type 10A

Type 8M – Teilung Pitch 8 mm für Riemenbreite for belt width 50 mm

Bezeichnung Part No.	Anzahl der Zähne No. of teeth	Aus- führung Type	Material	d _d (mm)	d _s (mm)	D _B (mm)	b ₁ (mm)	B (mm)	D (mm)	D _i (mm)	Vor- bohrung Pilot bore d (mm)	Fertig- bohrung Finished bore d _{max} (mm)	Gewicht Weight (≈ kg)	€ Stück each
22-8M-50	22	6F	St	56,02	54,65	60,0	60	70	43	—	12	30	1,00	auf Anfrage on request
24-8M-50	24	6F	St	61,12	59,75	66,0	60	70	45	—	12	30	1,20	
26-8M-50	26	6F	St	66,21	64,84	71,0	60	70	50	—	12	35	1,50	
28-8M-50	28	6F	St	71,30	69,93	75,0	60	70	50	—	15	35	1,67	
30-8M-50	30	6F	St	76,39	75,02	83,0	60	70	55	—	15	35	1,97	
32-8M-50	32	6F	St	81,49	80,12	87,0	60	70	60	—	15	40	2,27	
34-8M-50	34	6F	St	86,58	85,22	91,0	60	70	70	—	15	45	2,69	
36-8M-50	36	6F	St	91,67	90,30	98,5	60	70	70	—	15	45	2,97	
38-8M-50	38	6F	St	96,77	95,39	103,0	60	70	75	—	15	45	3,23	
40-8M-50	40	6F	GG	101,86	100,49	106,0	60	70	75	—	18	45	3,50	
44-8M-50	44	6F	GG	112,05	110,67	119,0	60	70	75	—	18	45	3,90	
48-8M-50	48	6F	GG	122,23	120,86	127,0	60	70	80	—	18	45	4,30	
56-8M-50	56	10WF	GG	142,60	141,23	148,0	60	60	90	117	18	50	5,00	
64-8M-50	64	10WF	GG	162,97	161,60	168,0	60	60	100	137	18	55	5,60	
72-8M-50	72	10WF	GG	183,35	181,97	192,0	60	60	100	158	18	55	6,80	
80-8M-50	80	10A	GG	203,72	202,35	—	60	60	110	180	18	60	6,90	
90-8M-50	90	10A	GG	229,18	227,81	—	60	60	110	204	18	60	8,60	
112-8M-50	112	10A	GG	285,21	283,83	—	60	60	110	260	18	60	9,60	
144-8M-50	144	10A	GG	366,69	365,32	—	60	60	110	341	20	60	13,80	
168-8M-50	168	10A	GG	427,81	426,44	—	60	60	120	402	20	65	16,00	
192-8M-50	192	10A	GG	488,92	487,55	—	60	60	130	463	20	70	22,40	

Type 8M – Teilung Pitch 8 mm für Riemenbreite for belt width 85 mm

22-8M-85	22	6F	St	56,02	54,65	60,0	95	105	43	—	12	30	1,55	auf Anfrage on request
24-8M-85	24	6F	St	61,12	59,75	66,0	95	105	45	—	12	30	1,90	
26-8M-85	26	6F	St	66,21	64,84	71,0	95	105	50	—	12	35	2,25	
28-8M-85	28	6F	St	71,30	69,93	75,0	95	105	50	—	15	35	2,55	
30-8M-85	30	6F	St	76,39	75,02	83,0	95	105	55	—	15	35	3,00	
32-8M-85	32	6F	St	81,49	80,12	87,0	95	105	60	—	15	40	3,57	
34-8M-85	34	6F	St	86,58	85,22	91,0	95	105	70	—	15	45	4,00	
36-8M-85	36	6F	St	91,67	90,30	98,5	95	105	70	—	15	45	4,50	
38-8M-85	38	6F	St	96,77	95,39	103,0	95	105	75	—	15	45	4,90	
40-8M-85	40	6F	GG	101,86	100,49	106,0	95	105	75	—	18	45	5,20	
44-8M-85	44	6F	GG	112,05	110,67	119,0	95	105	75	—	18	45	6,60	
48-8M-85	48	6F	GG	122,23	120,86	127,0	95	105	80	—	18	45	7,60	
56-8M-85	56	6F	GG	142,60	141,23	148,0	95	105	80	—	20	50	9,80	
64-8M-85	64	10WF	GG	162,97	161,60	168,0	95	95	100	137	20	55	10,40	
72-8M-85	72	10WF	GG	183,35	181,97	192,0	95	95	110	158	20	60	11,40	
80-8M-85	80	10A	GG	203,72	202,35	—	95	95	110	180	20	60	11,10	
90-8M-85	90	10A	GG	229,18	227,81	—	95	95	110	204	20	60	13,20	
112-8M-85	112	10A	GG	285,21	283,83	—	95	95	110	260	24	60	16,30	
144-8M-85	144	10A	GG	366,69	365,32	—	95	95	120	341	24	65	21,50	
168-8M-85	168	10A	GG	427,81	426,44	—	95	95	120	402	24	65	26,10	
192-8M-85	192	10A	GG	488,92	487,55	—	95	95	130	463	24	70	30,60	

St = Stahl Steel GG = Grauguss Cast iron

Fertigungstechnische Änderungen vorbehalten. We reserve the right to make technical changes.

HTD®-Zahnscheiben für zylindrische Bohrung HTD® pulleys for plain boring

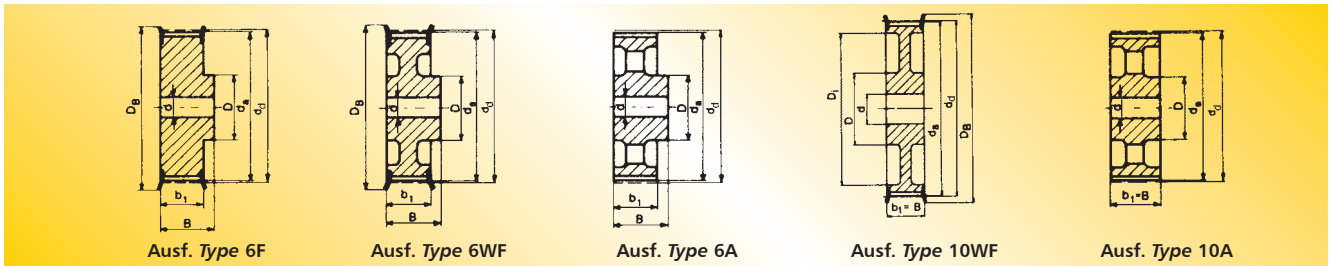

Type 14M – Teilung *Pitch* 14 mm für Riemenbreite *for belt width* 40 mm

Bezeichnung Part No.	Anzahl der Zähne No. of teeth	Aus- führung Type	Material	d _d (mm)	d _s (mm)	D _B (mm)	b ₁ (mm)	B (mm)	D (mm)	D ₁ (mm)	Vor- bohrung Pilot bore d (mm)	Fertig- bohrung Finished bore d _{max} (mm)	Gewicht Weight (≈ kg)	€ Stück each
28-14M-40	28	6F	GG	124,78	122,12	127	54	69	100	—	24	60	4,73	auf Anfrage on request
29-14M-40	29	6F	GG	129,23	126,57	138	54	69	100	—	24	60	5,09	
30-14M-40	30	6F	GG	133,69	130,99	138	54	69	100	—	24	60	5,45	
32-14M-40	32	6F	GG	142,60	139,88	154	54	69	100	—	24	70	6,17	
34-14M-40	34	6F	GG	151,52	148,79	160	54	69	100	—	24	70	6,88	
36-14M-40	36	6F	GG	160,43	157,68	168	54	69	100	—	24	70	7,60	
38-14M-40	38	6F	GG	169,34	166,60	183	54	69	120	—	24	70	8,28	
40-14M-40	40	6F	GG	178,25	175,49	188	54	69	120	—	24	70	9,26	
44-14M-40	44	6F	GG	196,08	193,28	211	54	69	120	—	24	70	10,32	
48-14M-40	48	6WF	GG	213,90	211,11	226	54	69	135	172	24	70	11,50	
56-14M-40	56	6WF	GG	249,55	246,76	256	54	69	135	207	28	70	13,05	
64-14M-40	64	6WF	GG	285,21	282,41	296	54	69	135	242	28	70	14,40	
72-14M-40	72	6A	GG	320,86	318,06	—	54	69	135	278	28	70	16,90	
80-14M-40	80	6A	GG	356,51	353,71	—	54	69	135	314	28	70	18,50	
90-14M-40	90	6A	GG	401,07	398,28	—	54	69	135	358	28	70	20,00	
112-14M-40	112	6A	GG	499,11	496,32	—	54	69	135	456	28	70	26,70	
144-14M-40	144	6A	GG	641,71	638,92	—	54	69	135	600	28	70	35,00	
168-14M-40	168	6A	GG	748,66	745,87	—	54	69	135	706	28	70	44,20	
192-14M-40	192	6A	GG	855,62	852,82	—	54	69	135	813	28	70	52,20	
216-14M-40	216	6A	GG	962,57	959,77	—	54	69	150	920	28	80	60,00	

Type 14M – Teilung *Pitch* 14 mm für Riemenbreite *for belt width* 55 mm

28-14M-55	28	6F	GG	124,78	122,12	127	70	85	100	—	24	60	5,60	auf Anfrage on request
29-14M-55	29	6F	GG	129,23	126,57	138	70	85	100	—	24	60	6,10	
30-14M-55	30	6F	GG	133,69	130,99	138	70	85	100	—	24	60	6,60	
32-14M-55	32	6F	GG	142,60	139,88	154	70	85	100	—	24	70	7,60	
34-14M-55	34	6F	GG	151,52	148,79	160	70	85	100	—	24	70	8,60	
36-14M-55	36	6F	GG	160,43	157,68	168	70	85	100	—	24	70	9,60	
38-14M-55	38	6F	GG	169,34	166,60	183	70	85	120	—	24	70	10,80	
40-14M-55	40	6F	GG	178,25	175,49	188	70	85	120	—	24	70	11,20	
44-14M-55	44	6F	GG	196,08	193,28	211	70	85	120	—	24	70	12,50	
48-14M-55	48	10WF	GG	213,90	211,11	226	70	70	135	172	24	70	13,70	
56-14M-55	56	10WF	GG	249,55	246,76	256	70	70	135	207	28	70	14,50	
64-14M-55	64	10WF	GG	285,21	282,41	296	70	70	135	242	28	70	15,60	
72-14M-55	72	10A	GG	320,86	318,06	—	70	70	135	278	28	70	18,50	
80-14M-55	80	10A	GG	356,51	353,71	—	70	70	135	314	28	70	20,00	
90-14M-55	90	10A	GG	401,07	398,28	—	70	70	135	358	28	70	22,60	
112-14M-55	112	10A	GG	499,11	496,32	—	70	70	135	456	28	70	29,50	
144-14M-55	144	10A	GG	641,71	638,92	—	70	70	135	600	28	70	39,00	
168-14M-55	168	10A	GG	748,66	745,87	—	70	70	135	706	28	70	48,50	
192-14M-55	192	10A	GG	855,62	852,82	—	70	70	135	813	28	70	57,80	
216-14M-55	216	10A	GG	962,57	959,77	—	70	70	150	920	28	80	67,00	

GG = Grauguss Cast iron

Fertigungstechnische Änderungen vorbehalten. We reserve the right to make technical changes.

HTD®-Zahnscheiben für zylindrische Bohrung HTD® pulleys for plain boring

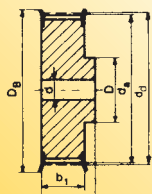

Ausf. Type 6F

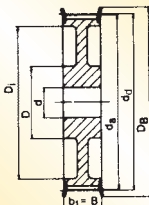

Ausf. Type 10WF

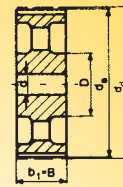

Ausf. Type 10A

Type 14M – Teilung Pitch 14 mm für Riemenbreite for belt width 85 mm

Bezeichnung Part No.	Anzahl der Zähne No. of teeth	Aus- führung Type	Material	d _d (mm)	d _s (mm)	D _B (mm)	b ₁ (mm)	B (mm)	D (mm)	D _i (mm)	Vor- bohrung Pilot bore d (mm)	Fertig- bohrung Finished bore d _{max} (mm)	Gewicht Weight (≈ kg)	€ Stück each
28-14M-85	28	6F	GG	124,78	122,12	127	102	117	100	—	24	60	7,70	auf Anfrage on request
29-14M-85	29	6F	GG	129,23	126,57	138	102	117	100	—	24	60	8,40	
30-14M-85	30	6F	GG	133,69	130,99	138	102	117	100	—	24	60	9,10	
32-14M-85	32	6F	GG	142,60	139,88	154	102	117	100	—	24	60	10,50	
34-14M-85	34	6F	GG	151,52	148,79	160	102	117	100	—	24	70	11,90	
36-14M-85	36	6F	GG	160,43	157,68	168	102	117	100	—	32	70	13,20	
38-14M-85	38	6F	GG	169,34	166,60	183	102	117	120	—	32	70	15,15	
40-14M-85	40	6F	GG	178,25	175,49	188	102	117	135	—	32	70	17,10	
44-14M-85	44	6F	GG	196,08	193,28	211	102	117	135	—	32	70	23,30	
48-14M-85	48	6F	GG	213,90	211,11	226	102	117	150	—	32	80	25,00	
56-14M-85	56	10WF	GG	249,55	246,76	256	102	102	150	207	32	80	25,00	
64-14M-85	64	10WF	GG	285,21	282,41	296	102	102	150	242	32	80	28,20	
72-14M-85	72	10A	GG	320,86	318,06	—	102	102	150	278	32	80	28,80	
80-14M-85	80	10A	GG	356,51	353,71	—	102	102	150	314	32	80	30,10	
90-14M-85	90	10A	GG	401,07	398,28	—	102	102	150	358	32	80	33,00	
112-14M-85	112	10A	GG	499,11	496,32	—	102	102	150	456	32	80	41,80	
144-14M-85	144	10A	GG	641,71	638,92	—	102	102	150	600	32	80	52,40	
168-14M-85	168	10A	GG	748,66	745,87	—	102	102	150	706	32	80	60,30	
192-14M-85	192	10A	GG	855,62	852,82	—	102	102	165	813	32	90	70,20	
216-14M-85	216	10A	GG	962,57	959,77	—	102	102	165	920	32	90	81,00	

Type 14M – Teilung Pitch 14 mm für Riemenbreite for belt width 115 mm

28-14M-115	28	6F	GG	124,78	122,12	127	133	148	100	—	32	60	9,20	auf Anfrage on request
29-14M-115	29	6F	GG	129,23	126,57	138	133	148	100	—	32	60	10,20	
30-14M-115	30	6F	GG	133,69	130,99	138	133	148	100	—	32	60	11,20	
32-14M-115	32	6F	GG	142,60	139,88	154	133	148	100	—	32	60	13,20	
34-14M-115	34	6F	GG	151,52	148,79	160	133	148	100	—	32	70	14,80	
36-14M-115	36	6F	GG	160,43	157,68	168	133	148	120	—	32	70	16,60	
38-14M-115	38	6F	GG	169,34	166,60	183	133	148	120	—	32	70	19,20	
40-14M-115	40	6F	GG	178,25	175,49	188	133	148	135	—	32	70	22,10	
44-14M-115	44	6F	GG	196,08	193,28	211	133	148	140	—	32	80	28,00	
48-14M-115	48	6F	GG	213,90	211,11	226	133	148	150	—	32	80	35,00	
56-14M-115	56	6F	GG	249,55	246,76	256	133	148	150	—	32	80	44,20	
64-14M-115	64	10WF	GG	285,21	282,41	296	133	133	150	242	32	80	36,80	
72-14M-115	72	10A	GG	320,86	318,06	—	133	133	150	278	32	80	36,10	
80-14M-115	80	10A	GG	356,51	353,71	—	133	133	150	314	32	80	38,60	
90-14M-115	90	10A	GG	401,07	398,28	—	133	133	150	358	32	80	41,00	
112-14M-115	112	10A	GG	499,11	496,32	—	133	133	150	456	32	80	54,40	
144-14M-115	144	10A	GG	641,71	638,92	—	133	133	165	600	32	90	67,80	
168-14M-115	168	10A	GG	748,66	745,87	—	133	133	165	706	32	90	75,80	
192-14M-115	192	10A	GG	855,62	852,82	—	133	133	165	813	32	90	88,30	
216-14M-115	216	10A	GG	962,57	959,77	—	133	133	165	920	32	90	98,00	

GG = Grauguss Cast iron

Fertigungstechnische Änderungen vorbehalten. We reserve the right to make technical changes.

HTD®-Zahnscheiben für zylindrische Bohrung HTD® pulleys for plain boring

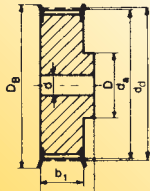

Ausf. Type 6F

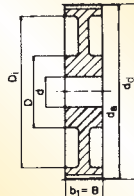

Ausf. Type 10W

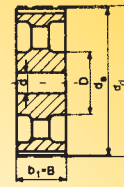

Ausf. Type 10A

Type 14M – Teilung Pitch 14 mm für Riemenbreite for belt width 170 mm

Bezeichnung Part No.	Anzahl der Zähne No. of teeth	Aus- führung Type	Material	d _d (mm)	d _s (mm)	D _B (mm)	b ₁ (mm)	B (mm)	D (mm)	D _i (mm)	Vor- bohrung Pilot bore d (mm)	Fertig- bohrung Finished bore d _{max} (mm)	Gewicht Weight (≈ kg)	€ Stück each
28-14M-170	28	6F	GG	124,78	122,12	127	187	202	100	—	32	60	13,80	auf Anfrage on request
29-14M-170	29	6F	GG	129,23	126,57	138	187	202	100	—	32	60	14,20	
30-14M-170	30	6F	GG	133,69	130,99	138	187	202	100	—	32	60	15,60	
32-14M-170	32	6F	GG	142,60	139,88	154	187	202	100	—	32	60	18,10	
34-14M-170	34	6F	GG	151,52	148,79	160	187	202	100	—	32	60	20,40	
36-14M-170	36	6F	GG	160,43	157,68	168	187	202	120	—	32	70	23,50	
38-14M-170	38	6F	GG	169,34	166,60	183	187	202	135	—	32	70	26,50	
40-14M-170	40	6F	GG	178,25	175,49	188	187	202	140	—	32	85	30,10	
44-14M-170	44	6F	GG	196,08	193,28	211	187	202	160	—	32	85	37,80	
48-14M-170	48	6F	GG	213,90	211,11	226	187	202	160	—	32	85	44,50	
56-14M-170	56	6F	GG	249,55	246,76	256	187	202	160	—	32	85	61,00	
64-14M-170	64	6F	GG	285,21	282,41	296	187	202	180	—	32	100	81,00	
72-14M-170	72	10W	GG	320,86	318,06	—	187	187	180	278	32	100	61,40	
80-14M-170	80	10W	GG	356,51	353,71	—	187	187	180	314	32	100	65,00	
90-14M-170	90	10A	GG	401,07	398,28	—	187	187	180	358	38	100	68,00	
112-14M-170	112	10A	GG	499,11	496,32	—	187	187	200	456	38	110	87,50	
144-14M-170	144	10A	GG	641,71	638,92	—	187	187	220	600	38	120	114,80	
168-14M-170	168	10A	GG	748,66	745,87	—	187	187	220	706	38	120	125,00	
192-14M-170	192	10A	GG	855,62	852,82	—	187	187	220	813	38	120	136,40	
216-14M-170	216	10A	GG	962,57	959,77	—	187	187	220	920	38	120	147,00	

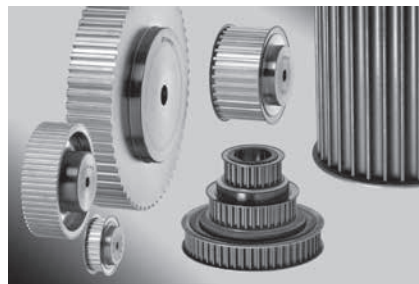

HTD®-Zahnscheiben Type 20M auf Anfrage HTD® pulleys type 20M on request

GG = Grauguss Cast iron

Fertigungstechnische Änderungen vorbehalten. We reserve the right to make technical changes.

HTD®-Zahnscheiben für Taperbuchsen HTD® pulleys for taper bushes

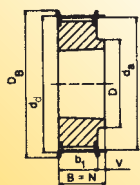

Ausf. Type 8F

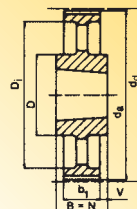

Ausf. Type 7A

Type 5M – Teilung Pitch 5 mm für Riemenbreite for belt width 15 mm

Bezeichnung Part No.	Anzahl der Zähne No. of teeth	Aus- führung Type	Material	d_d (mm)	d_s (mm)	D_B (mm)	b_1 (mm)	B (mm)	N (mm)	V (mm)	Z (mm)	D (mm)	D_i (mm)	Taper- Buchse Taper bush	Gewicht ohne Buchse Weight without bush (≈ kg)	€ Stück ohne Buchse each without bush
TB 34-5M-15	34	8F	St	54,11	52,97	57,0	20,5	22	22	1,5	—	43	—	1008	0,190	auf Anfrage on request
TB 36-5M-15	36	8F	St	57,30	56,16	60,0	20,5	22	22	1,5	—	44	—	1108	0,200	
TB 38-5M-15	38	8F	St	60,48	59,34	66,0	20,5	22	22	1,5	—	48	—	1108	0,250	
TB 40-5M-15	40	8F	St	63,66	62,52	71,0	20,5	22	22	1,5	—	52	—	1108	0,310	
TB 44-5M-15	44	8F	St	70,03	68,89	75,0	20,5	22	22	1,5	—	54	—	1108	0,400	
TB 48-5M-15	48	8F	St	76,39	75,25	83,0	20,5	25	25	4,5	—	64	—	1210	0,450	
TB 56-5M-15	56	8F	GG	89,13	87,99	93,0	20,5	25	25	4,5	—	70	—	1210	0,670	
TB 64-5M-15	64	8F	GG	101,86	100,72	106,0	20,5	25	25	4,5	—	78	—	1210	0,960	
TB 72-5M-15	72	8F	GG	114,59	113,45	119,0	20,5	25	25	4,5	—	90	—	1610	1,190	
TB 80-5M-15	80	8F	GG	127,32	126,18	135,0	20,5	25	25	4,5	—	92	—	1610	1,570	
TB 90-5M-15	90	7A	GG	143,24	142,10	—	20,5	25	25	2,3	—	92	—	1610	1,147	
TB 112-5M-15	112	7A	GG	178,25	177,11	—	20,5	25	25	2,3	—	92	—	1610	1,940	
TB 136-5M-15	136	7A	GG	216,45	215,31	—	20,5	32	32	5,8	—	106	—	2012	3,060	
TB 150-5M-15	150	7A	GG	238,73	237,59	—	20,5	32	32	5,8	—	106	—	2012	3,900	

52

Taperbuchse Taper bush	1008	1108	1210	1610	2012
Bohrung d_2 (mm) von ... bis ... Bore d_2 (mm) from ... to ...	10-25	10-28	11-32	14-42	14-50
€/Stück each	auf Anfrage / on request				

St = Stahl Steel
GG = Grauguss Cast iron
Fertigungstechnische Änderungen vorbehalten.
We reserve the right to make technical changes.
Bohrungsdurchmesser d_2 siehe Seite 3-4.
Bore diameters d_2 see page 3-4.

HTD®-Zahnscheiben für Taperbuchsen HTD® pulleys for taper bushes

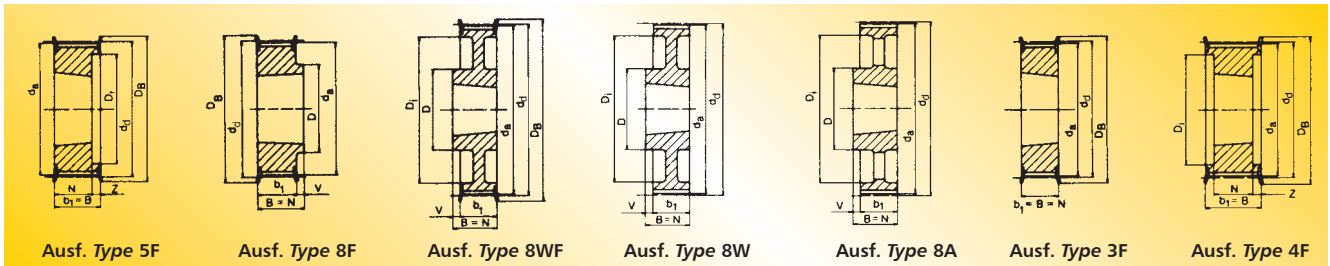

Type 8M – Teilung Pitch 8 mm für Riemenbreite for belt width 20 mm

Bezeichnung Part No.	Anzahl der Zähne No. of teeth	Ausführung Type	Material	d_d (mm)	d_s (mm)	D_B (mm)	b_1 (mm)	B (mm)	N (mm)	V (mm)	Z (mm)	D (mm)	D_i (mm)	Taper-Buchse Taper bush	Gewicht ohne Buchse Weight without bush (= kg)	€ Stück ohne Buchse each without bush
TB 22-8M-20	22	5F	GG	56,02	54,65	60,0	28	28	22	—	6	—	41	1008	0,24	auf Anfrage on request
TB 24-8M-20	24	5F	GG	61,12	59,75	66,0	28	28	22	—	6	—	42	1108	0,30	
TB 26-8M-20	26	5F	GG	66,21	64,84	71,0	28	28	22	—	6	—	46	1108	0,36	
TB 28-8M-20	28	5F	GG	71,30	69,93	75,0	28	28	22	—	6	—	50	1108	0,44	
TB 30-8M-20	30	5F	GG	76,39	75,02	83,0	28	28	22	—	6	—	58	1108	0,53	
TB 32-8M-20	32	5F	GG	81,49	80,12	87,0	28	28	25	—	3	—	62	1610	0,42	
TB 34-8M-20	34	5F	GG	86,58	85,22	91,0	28	28	25	—	3	—	65	1610	0,55	
TB 36-8M-20	36	5F	GG	91,67	90,30	98,5	28	28	25	—	3	—	68	1610	0,68	
TB 38-8M-20	38	5F	GG	96,77	95,39	103,0	28	28	25	—	3	—	72	1610	0,80	
TB 40-8M-20	40	5F	GG	101,86	100,49	106,0	28	28	25	—	3	—	76	1610	1,00	
TB 44-8M-20	44	8F	GG	112,05	110,67	119,0	28	32	32	4	—	93	—	2012	1,20	
TB 48-8M-20	48	8F	GG	122,23	120,86	127,0	28	32	32	4	—	96	—	2012	1,60	
TB 56-8M-20	56	8F	GG	142,60	141,23	148,0	28	32	32	4	—	110	—	2012	2,40	
TB 64-8M-20	64	8WF	GG	162,97	161,60	168,0	28	32	32	4	—	110	137	2012	2,70	
TB 72-8M-20	72	8WF	GG	183,35	181,97	192,0	28	32	32	4	—	110	158	2012	3,30	
TB 80-8M-20	80	8W	GG	203,72	202,35	—	28	32	32	4	—	110	180	2012	3,50	
TB 90-8M-20	90	8A	GG	229,18	227,81	—	28	32	32	4	—	110	204	2012	3,65	

Type 8M – Teilung Pitch 8 mm für Riemenbreite for belt width 30 mm

TB 22-8M-30	22	5F	GG	56,02	54,65	60,0	38	38	22	—	16	—	41	1008	0,29	auf Anfrage on request
TB 24-8M-30	24	5F	GG	61,12	59,75	66,0	38	38	22	—	16	—	42	1108	0,38	
TB 26-8M-30	26	5F	GG	66,21	64,84	71,0	38	38	22	—	16	—	46	1108	0,45	
TB 28-8M-30	28	5F	St	71,30	69,93	75,0	38	38	25	—	13	—	50	1210	0,50	
TB 30-8M-30	30	3F	St	76,39	75,02	83,0	38	38	38	—	—	—	—	1615	0,45	
TB 32-8M-30	32	3F	GG	81,49	80,12	87,0	38	38	38	—	—	—	—	1615	0,59	
TB 34-8M-30	34	3F	GG	86,58	85,22	91,0	38	38	38	—	—	—	—	1615	0,77	
TB 36-8M-30	36	3F	GG	91,67	90,30	98,5	38	38	38	—	—	—	—	1615	0,96	
TB 38-8M-30	38	3F	GG	96,77	95,39	103,0	38	38	38	—	—	—	—	1615	1,15	
TB 40-8M-30	40	3F	GG	101,86	100,49	106,0	38	38	38	—	—	—	—	1615	1,34	
TB 44-8M-30	44	4F	GG	112,05	110,67	119,0	38	38	32	—	3	—	91	2012	1,33	
TB 48-8M-30	48	4F	GG	122,23	120,86	127,0	38	38	32	—	3	—	95	2012	1,78	
TB 56-8M-30	56	4F	GG	142,60	141,23	148,0	38	38	32	—	3	—	117	2012	3,76	
TB 64-8M-30	64	8F	GG	162,97	161,60	168,0	38	45	45	7	—	125	—	2517	4,20	
TB 72-8M-30	72	8WF	GG	183,35	181,97	192,0	38	45	45	7	—	125	158	2517	4,30	
TB 80-8M-30	80	8W	GG	203,72	202,35	—	38	45	45	7	—	125	180	2517	4,60	
TB 90-8M-30	90	8A	GG	229,18	227,81	—	38	45	45	7	—	125	204	2517	5,00	
TB 112-8M-30	112	8A	GG	285,21	283,83	—	38	45	45	7	—	125	260	2517	6,20	
TB 144-8M-30	144	8A	GG	366,69	365,32	—	38	45	45	7	—	125	341	2517	9,00	

Taperbuchse Taper bush	1008	1108	1210	1610	1615	2012	2517
Bohrung d_2 (mm) von ... bis ... Bore d_2 (mm) from ... to ...	10-25	10-28	11-32	14-42	14-42	14-50	16-60
€/Stück each	auf Anfrage / on request						

GG = Grauguss Cast iron
St = Stahl Steel
Fertigungstechnische Änderungen vorbehalten.
We reserve the right to make technical changes.
Bohrungsdurchmesser d_2 siehe Seite 3-4.
Bore diameters d_2 see page 3-4.

HTD®-Zahnscheiben für Taperbuchsen HTD® pulleys for taper bushes

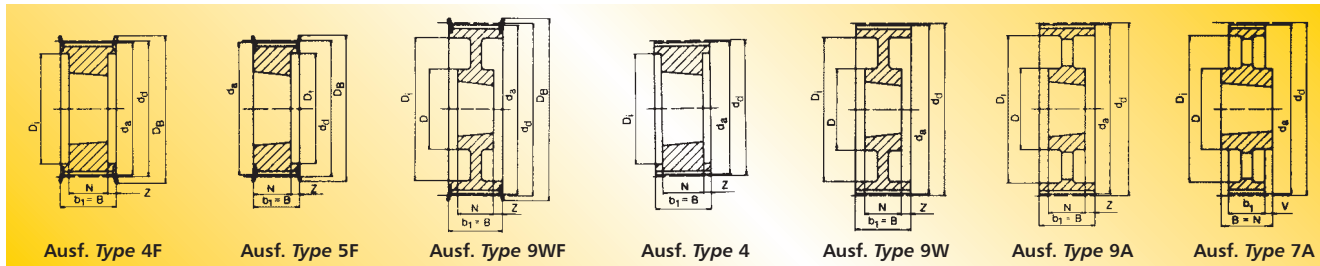

Type 8M – Teilung Pitch 8 mm für Riemenbreite for belt width 50 mm

Bezeichnung Part No.	Anzahl der Zähne No. of teeth	Aus- führung Type	Material	d _d (mm)	d _s (mm)	D _B (mm)	b ₁ (mm)	B (mm)	N (mm)	V (mm)	Z (mm)	D (mm)	D _i (mm)	Taper- Buchse Taper bush	Gewicht ohne Buchse Weight without bush (≈ kg)	€ Stück ohne Buchse each without bush
TB 28-8M-50	28	5F	St	71,30	69,93	75,0	60	60	25	—	35,0	—	50	1210	0,60	auf Anfrage on request
TB 30-8M-50	30	5F	St	76,39	75,02	83,0	60	60	38	—	22,0	—	58	1615	0,65	
TB 32-8M-50	32	5F	GG	81,49	80,12	87,0	60	60	38	—	22,0	—	62	1615	0,82	
TB 34-8M-50	34	5F	GG	86,58	85,22	91,0	60	60	38	—	22,0	—	65	1615	1,06	
TB 36-8M-50	36	5F	GG	91,67	90,30	98,5	60	60	38	—	22,0	—	68	1615	1,30	
TB 38-8M-50	38	5F	GG	96,77	95,39	103,0	60	60	38	—	22,0	—	72	1615	1,60	
TB 40-8M-50	40	4F	GG	101,86	100,49	106,0	60	60	32	—	14,0	—	82	2012	1,71	
TB 44-8M-50	44	4F	GG	112,05	110,67	119,0	60	60	32	—	14,0	—	91	2012	1,78	
TB 48-8M-50	48	4F	GG	122,23	120,86	127,0	60	60	32	—	14,0	—	95	2012	2,30	
TB 56-8M-50	56	4F	GG	142,60	141,23	148,0	60	60	45	—	7,5	—	116	2517	3,40	
TB 64-8M-50	64	4F	GG	162,97	161,60	168,0	60	60	45	—	7,5	—	137	2517	5,00	
TB 72-8M-50	72	9WF	GG	183,35	181,97	192,0	60	60	45	—	7,5	125	158	2517	6,70	
TB 80-8M-50	80	4	GG	203,72	202,35	—	60	60	51	—	4,5	—	180	3020	8,80	
TB 90-8M-50	90	9W	GG	229,18	227,81	—	60	60	51	—	4,5	170	204	3020	10,00	
TB 112-8M-50	112	9W	GG	285,21	283,83	—	60	60	51	—	4,5	170	260	3020	12,00	
TB 144-8M-50	144	9A	GG	366,69	365,32	—	60	60	51	—	4,5	170	341	3020	15,20	
TB 168-8M-50	168	7A	GG	427,81	426,44	—	60	65	65	—	2,5	170	402	3525	16,40	
TB 192-8M-50	192	7A	GG	488,92	487,55	—	60	65	65	—	2,5	170	460	3525	21,80	

Type 8M – Teilung Pitch 8 mm für Riemenbreite for belt width 85 mm

TB 34-8M-85	34	4F	GG	86,58	85,22	91,0	95	95	38	—	28,5	—	65	1615	1,43	auf Anfrage on request
TB 36-8M-85	36	4F	GG	91,67	90,30	98,5	95	95	38	—	28,5	—	68	1615	1,87	
TB 38-8M-85	38	4F	GG	96,77	95,39	103,0	95	95	38	—	28,5	—	72	1615	2,20	
TB 40-8M-85	40	4F	GG	101,86	100,49	106,0	95	95	32	—	31,5	—	82	2012	1,78	
TB 44-8M-85	44	4F	GG	112,05	110,67	119,0	95	95	32	—	31,5	—	91	2012	2,30	
TB 48-8M-85	48	4F	GG	122,23	120,86	127,0	95	95	45	—	25,0	—	100	2517	2,66	
TB 56-8M-85	56	4F	GG	142,60	141,23	148,0	95	95	45	—	25,0	—	117	2517	4,45	
TB 64-8M-85	64	4F	GG	162,97	161,60	168,0	95	95	45	—	25,0	—	137	2517	6,20	
TB 72-8M-85	72	4F	GG	183,35	181,97	192,0	95	95	51	—	22,0	—	158	3020	8,00	
TB 80-8M-85	80	4	GG	203,72	202,35	—	95	95	51	—	22,0	—	180	3020	10,00	
TB 90-8M-85	90	9W	GG	229,18	227,81	—	95	95	51	—	22,0	170	204	3020	10,80	
TB 112-8M-85	112	9W	GG	285,21	283,83	—	95	95	51	—	22,0	170	260	3020	15,00	
TB 144-8M-85	144	9A	GG	366,69	365,32	—	95	95	76	—	15,0	170	341	3525	20,00	
TB 168-8M-85	168	9A	GG	427,81	426,44	—	95	95	76	—	15,0	170	402	3525	23,00	
TB 192-8M-85	192	9A	GG	488,92	487,55	—	95	95	76	—	15,0	170	460	3525	28,50	

Taperbuchse Taper bush	1210	1615	2012	2517	3020	3525
Bohrung d ₂ (mm) von ... bis ... Bore d ₂ (mm) from ... to ...	11-32	14-42	14-50	16-60	25-75	35-90
€/Stück each	auf Anfrage / on request					

GG = Grauguss Cast iron
St = Stahl Steel
Fertigungstechnische Änderungen vorbehalten.
We reserve the right to make technical changes.
Bohrungsdurchmesser d₂ siehe Seite 3-4.
Bore diameters d₂ see page 3-4.

HTD®-Zahnscheiben für Taperbuchsen HTD® pulleys for taper bushes

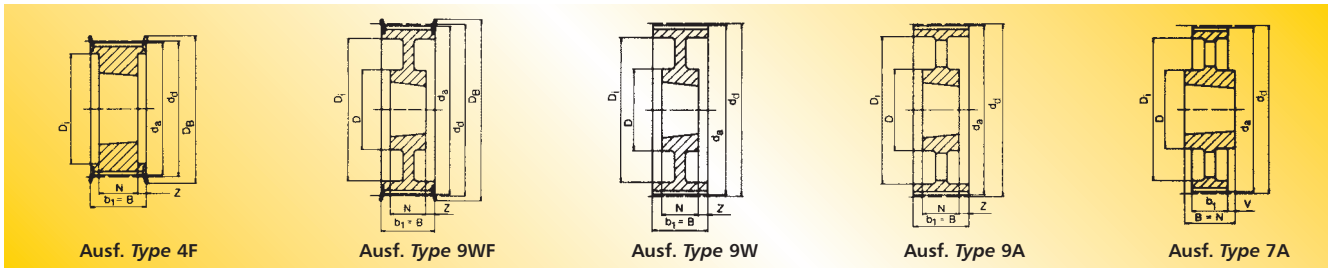

Type 14M – Teilung *Pitch* 14 mm für Riemenbreite *for belt width* 40 mm

Bezeichnung Part No.	Anzahl der Zähne No. of teeth	Aus- führung Type	Material	d _d (mm)	d _s (mm)	D _B (mm)	b ₁ (mm)	B (mm)	N (mm)	V (mm)	Z (mm)	D (mm)	D ₁ (mm)	Taper- Buchse Taper bush	Gewicht ohne Buchse Weight without bush (= kg)	€ Stück ohne Buchse each without bush
TB 28-14M-40	28	4F	GG	124,78	122,12	127	54	54	32	—	11,0	—	98	2012	2,00	auf Anfrage on request
TB 29-14M-40	29	4F	GG	129,23	126,57	138	54	54	32	—	11,0	—	100	2012	2,38	
TB 30-14M-40	30	4F	GG	133,69	130,99	138	54	54	32	—	11,0	—	100	2012	2,65	
TB 32-14M-40	32	4F	GG	142,60	139,88	154	54	54	32	—	11,0	—	104	2012	3,40	
TB 34-14M-40	34	4F	GG	151,52	148,79	160	54	54	45	—	4,5	—	110	2517	3,87	
TB 36-14M-40	36	4F	GG	160,43	157,68	168	54	54	45	—	4,5	—	120	2517	4,80	
TB 38-14M-40	38	4F	GG	169,34	166,60	183	54	54	45	—	4,5	—	130	2517	5,40	
TB 40-14M-40	40	4F	GG	178,25	175,49	188	54	54	45	—	4,5	—	138	2517	6,00	
TB 44-14M-40	44	4F	GG	196,08	193,28	211	54	54	51	—	1,5	—	155	3020	7,80	
TB 48-14M-40	48	4F	GG	213,90	211,11	226	54	54	51	—	1,5	—	170	3020	9,40	
TB 56-14M-40	56	9WF	GG	249,55	246,76	256	54	54	51	—	1,5	170	208	3020	10,80	
TB 64-14M-40	64	9WF	GG	285,21	282,41	296	54	54	51	—	1,5	170	242	3020	13,40	
TB 72-14M-40	72	9W	GG	320,86	318,06	—	54	54	51	—	1,5	170	280	3020	15,20	
TB 80-14M-40	80	9A	GG	356,51	353,71	—	54	54	51	—	1,5	170	315	3020	16,00	
TB 90-14M-40	90	9A	GG	401,07	398,28	—	54	54	51	—	1,5	170	360	3020	17,80	
TB 112-14M-40	112	9A	GG	499,11	496,32	—	54	54	51	—	1,5	170	457	3020	25,60	
TB 144-14M-40	144	9A	GG	641,71	638,92	—	54	54	51	—	1,5	170	600	3020	32,00	
TB 168-14M-40	168	9A	GG	748,66	745,87	—	54	54	51	—	1,5	170	706	3020	44,00	
TB 192-14M-40	192	9A	GG	855,62	852,82	—	54	54	51	—	1,5	170	813	3020	49,00	
TB 216-14M-40	216	9A	GG	962,57	959,77	—	54	54	51	—	1,5	170	920	3020	55,00	

Type 14M – Teilung *Pitch* 14 mm für Riemenbreite *for belt width* 55 mm

TB 28-14M-55	28	4F	GG	124,78	122,12	127	70	70	32	—	19,0	—	98	2012	2,20	auf Anfrage on request
TB 29-14M-55	29	4F	GG	129,23	126,57	138	70	70	32	—	19,0	—	100	2012	2,74	
TB 30-14M-55	30	4F	GG	133,69	130,99	138	70	70	45	—	12,5	—	100	2517	2,70	
TB 32-14M-55	32	4F	GG	142,60	139,88	154	70	70	45	—	12,5	—	108	2517	3,66	
TB 34-14M-55	34	4F	GG	151,52	148,79	160	70	70	45	—	12,5	—	110	2517	4,55	
TB 36-14M-55	36	4F	GG	160,43	157,68	168	70	70	45	—	12,5	—	120	2517	5,20	
TB 38-14M-55	38	4F	GG	169,34	166,60	183	70	70	45	—	12,5	—	130	2517	6,20	
TB 40-14M-55	40	4F	GG	178,25	175,49	188	70	70	45	—	12,5	—	138	2517	7,00	
TB 44-14M-55	44	4F	GG	196,08	193,28	211	70	70	51	—	9,5	—	155	3020	8,60	
TB 48-14M-55	48	4F	GG	213,90	211,11	226	70	70	51	—	9,5	—	170	3020	10,40	
TB 56-14M-55	56	9WF	GG	249,55	246,76	256	70	70	51	—	9,5	170	208	3020	12,00	
TB 64-14M-55	64	9WF	GG	285,21	282,41	296	70	70	51	—	9,5	170	242	3020	14,50	
TB 72-14M-55	72	9W	GG	320,86	318,06	—	70	70	51	—	9,5	170	280	3020	16,20	
TB 80-14M-55	80	9A	GG	356,51	353,71	—	70	70	51	—	9,5	170	315	3020	17,50	
TB 90-14M-55	90	9A	GG	401,07	398,28	—	70	70	51	—	9,5	170	360	3020	20,10	
TB 112-14M-55	112	9A	GG	499,11	496,32	—	70	70	51	—	9,5	170	457	3020	28,40	
TB 144-14M-55	144	9A	GG	641,71	638,92	—	70	70	51	—	9,5	170	600	3020	36,20	
TB 168-14M-55	168	9A	GG	748,66	745,87	—	70	70	51	—	9,5	170	706	3020	49,00	
TB 192-14M-55	192	9A	GG	855,62	852,82	—	70	70	51	—	9,5	170	813	3020	53,00	
TB 216-14M-55	216	7A	GG	962,57	959,77	—	70	89	89	9,5	—	190	920	3535	65,80	

Taperbuchse Taper bush	2012	2517	3020	3535
Bohrung d ₂ (mm) von ... bis ... Bore d ₂ (mm) from ... to ...	14-50	16-60	25-75	35-90
€/Stück each	auf Anfrage / on request			

GG = Grauguss Cast iron
Fertigungstechnische Änderungen vorbehalten.
We reserve the right to make technical changes.

Bohrungsdurchmesser d₂ siehe Seite 3-4.
Bore diameters d₂ see page 3-4.

HTD®-Zahnscheiben für Taperbuchsen HTD® pulleys for taper bushes

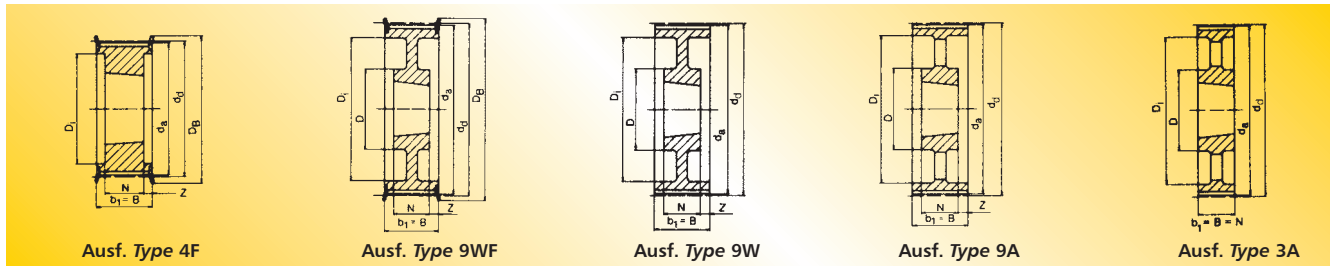

Type 14M – Teilung Pitch 14 mm für Riemenbreite for belt width 85 mm

Bezeichnung Part No.	Anzahl der Zähne No. of teeth	Aus- führung Type	Material	d _d (mm)	d _a (mm)	D _B (mm)	b ₁ (mm)	B (mm)	N (mm)	V (mm)	Z (mm)	D (mm)	D _i (mm)	Taper- Buchse Taper bush	Gewicht ohne Buchse Weight without bush (≈ kg)	€ Stück ohne Buchse each without bush
TB 28-14M-85	28	4F	GG	124,78	122,12	127	102	102	45	—	28,5	—	98	2517	2,70	auf Anfrage on request
TB 29-14M-85	29	4F	GG	129,23	126,57	138	102	102	45	—	28,5	—	100	2517	3,40	
TB 30-14M-85	30	4F	GG	133,69	130,99	138	102	102	45	—	28,5	—	100	2517	3,75	
TB 32-14M-85	32	4F	GG	142,60	139,88	154	102	102	45	—	28,5	—	108	2517	4,80	
TB 34-14M-85	34	4F	GG	151,52	148,79	160	102	102	45	—	28,5	—	110	2517	6,00	
TB 36-14M-85	36	4F	GG	160,43	157,68	168	102	102	51	—	25,5	—	120	3020	5,80	
TB 38-14M-85	38	4F	GG	169,34	166,60	183	102	102	51	—	25,5	—	130	3020	6,80	
TB 40-14M-85	40	4F	GG	178,25	175,49	188	102	102	51	—	25,5	—	138	3020	8,00	
TB 44-14M-85	44	4F	GG	196,08	193,28	211	102	102	76	—	13,0	—	155	3030	11,80	
TB 48-14M-85	48	4F	GG	213,90	211,11	226	102	102	76	—	13,0	—	170	3030	15,10	
TB 56-14M-85	56	4F	GG	249,55	246,76	256	102	102	65	—	18,5	190	210	3525	19,00	
TB 64-14M-85	64	9WF	GG	285,21	282,41	296	102	102	65	—	18,5	190	242	3525	23,00	
TB 72-14M-85	72	9W	GG	320,86	318,06	—	102	102	65	—	18,5	190	280	3525	25,00	
TB 80-14M-85	80	9A	GG	356,51	353,71	—	102	102	65	—	18,5	190	315	3525	26,00	
TB 90-14M-85	90	9A	GG	401,07	398,28	—	102	102	65	—	18,5	190	360	3525	27,80	
TB 112-14M-85	112	9A	GG	499,11	496,32	—	102	102	65	—	18,5	190	457	3525	36,50	
TB 144-14M-85	144	9A	GG	641,71	638,92	—	102	102	65	—	18,5	190	600	3525	48,00	
TB 168-14M-85	168	9A	GG	748,66	745,87	—	102	102	65	—	18,5	190	706	3525	60,00	
TB 192-14M-85	192	3A	GG	855,62	852,82	—	102	102	102	—	—	230	813	4040	86,00	
TB 216-14M-85	216	3A	GG	962,57	959,77	—	102	102	102	—	—	230	920	4040	91,50	

Type 14M – Teilung Pitch 14 mm für Riemenbreite for belt width 115 mm

TB 28-14M-115	28	4F	GG	124,78	122,12	127	133	133	45	—	44,0	—	98	2517	3,77	auf Anfrage on request
TB 29-14M-115	29	4F	GG	129,23	126,57	138	133	133	45	—	44,0	—	100	2517	4,00	
TB 30-14M-115	30	4F	GG	133,69	130,99	138	133	133	45	—	44,0	—	100	2517	5,00	
TB 32-14M-115	32	4F	GG	142,60	139,88	154	133	133	45	—	44,0	—	108	2517	6,80	
TB 34-14M-115	34	4F	GG	151,52	148,79	160	133	133	45	—	44,0	—	110	2517	6,80	
TB 36-14M-115	36	4F	GG	160,43	157,68	168	133	133	51	—	41,0	—	120	3020	7,00	
TB 38-14M-115	38	4F	GG	169,34	166,60	183	133	133	51	—	41,0	—	130	3020	8,40	
TB 40-14M-115	40	4F	GG	178,25	175,49	188	133	133	51	—	41,0	—	140	3020	9,20	
TB 44-14M-115	44	4F	GG	196,08	193,28	211	133	133	76	—	28,5	—	155	3030	14,00	
TB 48-14M-115	48	4F	GG	213,90	211,11	226	133	133	76	—	28,5	—	170	3030	17,10	
TB 56-14M-115	56	4F	GG	249,55	246,76	256	133	133	89	—	22,0	—	210	3535	24,80	
TB 64-14M-115	64	9WF	GG	285,21	282,41	296	133	133	89	—	22,0	190	242	3535	27,00	
TB 72-14M-115	72	9W	GG	320,86	318,06	—	133	133	89	—	22,0	190	280	3535	29,00	
TB 80-14M-115	80	9A	GG	356,51	353,71	—	133	133	89	—	22,0	190	315	3535	32,00	
TB 90-14M-115	90	9A	GG	401,07	398,28	—	133	133	89	—	22,0	190	360	3535	36,50	
TB 112-14M-115	112	9A	GG	499,11	496,32	—	133	133	89	—	22,0	190	457	3535	46,00	
TB 144-14M-115	144	9A	GG	641,71	638,92	—	133	133	102	—	15,5	230	600	4040	68,00	
TB 168-14M-115	168	9A	GG	748,66	745,87	—	133	133	102	—	15,5	230	706	4040	82,60	
TB 192-14M-115	192	9A	GG	855,62	852,82	—	133	133	102	—	15,5	230	813	4040	96,00	
TB 216-14M-115	216	9A	GG	962,57	959,77	—	133	133	102	—	15,5	230	920	4040	107,00	

Taperbuchse Taper bush	2517	3020	3030	3525	3535	4040
Bohrung d ₂ (mm) von ... bis ... Bore d ₂ (mm) from ... to ...	16-60	25-75	35-75	35-90	35-90	40-100
€/Stück each	auf Anfrage / on request					

GG = Grauguss Cast iron
Fertigungstechnische Änderungen vorbehalten.
We reserve the right to make technical changes.

Bohrungsdurchmesser d₂ siehe Seite 3-4.
Bore diameters d₂ see page 3-4.

HTD®-Zahnscheiben für Taperbuchsen HTD® pulleys for taper bushes

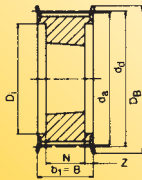

Ausf. Type 4F

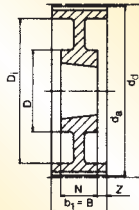

Ausf. Type 9W

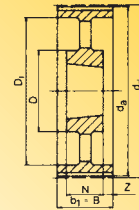

Ausf. Type 9A

Type 14M – Teilung Pitch 14 mm für Riemenbreite for belt width 170 mm

Bezeichnung Part No.	Anzahl der Zähne No. of teeth	Aus- führung Type	Material	d _d (mm)	d _s (mm)	D _B (mm)	b ₁ (mm)	B (mm)	N (mm)	V (mm)	Z (mm)	D (mm)	D _i (mm)	Taper- Buchse Taper bush	Gewicht ohne Buchse Weight without bush (≈ kg)	€ Stück ohne Buchse each without bush
TB 38-14M-170	38	4F	GG	169,34	166,60	183	187	187	76	—	55,5	—	130	3030	11,70	auf Anfrage on request
TB 40-14M-170	40	4F	GG	178,25	175,49	188	187	187	76	—	55,5	—	140	3030	13,00	
TB 44-14M-170	44	4F	GG	196,08	193,28	211	187	187	89	—	49,0	—	155	3535	15,00	
TB 48-14M-170	48	4F	GG	213,90	211,11	226	187	187	89	—	49,0	—	175	3535	19,00	
TB 56-14M-170	56	4F	GG	249,55	246,76	256	187	187	89	—	49,0	—	210	3535	28,50	
TB 64-14M-170	64	4F	GG	285,21	282,41	296	187	187	102	—	42,5	—	240	4040	41,00	
TB 72-14M-170	72	9W	GG	320,86	318,06	—	187	187	102	—	42,5	230	280	4040	46,90	
TB 80-14M-170	80	9W	GG	356,51	353,71	—	187	187	102	—	42,5	230	315	4040	48,00	
TB 90-14M-170	90	9A	GG	401,07	398,28	—	187	187	102	—	42,5	230	360	4040	52,50	
TB 112-14M-170	112	9A	GG	499,11	496,32	—	187	187	127	—	30,0	265	457	5050	74,50	
TB 144-14M-170	144	9A	GG	641,71	638,92	—	187	187	127	—	30,0	265	600	5050	91,00	
TB 168-14M-170	168	9A	GG	748,66	745,87	—	187	187	127	—	30,0	265	706	5050	116,00	
TB 192-14M-170	192	9A	GG	855,62	852,82	—	187	187	127	—	30,0	265	813	5050	134,00	
TB 216-14M-170	216	9A	GG	962,57	959,77	—	187	187	127	—	30,0	265	920	5050	146,50	

HTD®-Zahnscheiben Type 20M auf Anfrage HTD® pulleys type 20M on request

Taperbuchse Taper bush	3030	3535	4040	5050
Bohrung d ₂ (mm) von ... bis ... Bore d ₂ (mm) from ... to ...	35-75	35-90	40-100	70-125
€/Stück each	auf Anfrage / on request			

GG = Grauguss Cast iron
Fertigungstechnische Änderungen vorbehalten.
We reserve the right to make technical changes.

Bohrungsdurchmesser d₂ siehe Seite 3-4.
Bore diameters d₂ see page 3-4.

Metrische Zahnscheiben für zylindrische Bohrung Metric timing belt pulleys for plain boring

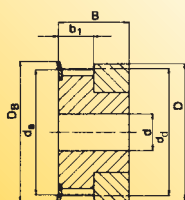

Ausf. Type 1F

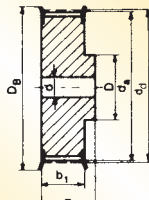

Ausf. Type 6F

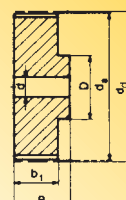

Ausf. Type 6

Type T2,5 – Teilung *Pitch* 2,5 mm für Riemenbreite *for belt width* 4 und *and* 6 mm

Bezeichnung Part No.	Anzahl der Zähne No. of teeth	Aus- führung Type	Material	d_d (mm)	d_s (mm)	D_B (mm)	b_1 (mm)	B (mm)	D (mm)	D_i (mm)	Vor- bohrung Pilot bore d (mm)	Fertig- bohrung Finished bore d_{max} (mm)	Gewicht Weight (≈ kg)	€ Stück each
16 T2,5/12-2	12	1F	Al	9,55	9,00	13,0	9	16	12	—	—	3	0,003	auf Anfrage on request
16 T2,5/14-2	14	1F	Al	11,14	10,60	15,0	9	16	14	—	—	4	0,004	
16 T2,5/15-2	15	1F	Al	11,94	11,40	15,0	9	16	15	—	—	4	0,005	
16 T2,5/16-2	16	1F	Al	12,73	12,20	16,0	9	16	16	—	—	5	0,005	
16 T2,5/18-2	18	6F	Al	14,32	13,80	17,5	10	16	9,5	—	4	6	0,006	
16 T2,5/19-2	19	6F	Al	15,12	14,60	18,0	10	16	9,5	—	4	6	0,007	
16 T2,5/20-2	20	6F	Al	15,92	15,40	19,5	10	16	10	—	4	6	0,008	
16 T2,5/22-2	22	6F	Al	17,51	17,00	23,0	10	16	10	—	4	6	0,009	
16 T2,5/24-2	24	6F	Al	19,10	18,55	23,0	10	16	12	—	4	6	0,012	
16 T2,5/25-2	25	6F	Al	19,90	19,35	23,0	10	16	12	—	4	8	0,013	
16 T2,5/26-2	26	6F	Al	20,70	20,15	25,0	10	16	13	—	4	8	0,014	
16 T2,5/28-2	28	6F	Al	22,28	21,75	25,0	10	16	13	—	4	8	0,016	
16 T2,5/30-2	30	6F	Al	23,87	23,35	28,0	10	16	16	—	6	10	0,018	
16 T2,5/32-2	32	6F	Al	25,47	24,95	32,0	10	16	16	—	6	10	0,020	
16 T2,5/36-2	36	6F	Al	28,65	28,10	36,0	10	16	20	—	6	12	0,026	
16 T2,5/40-2	40	6F	Al	31,83	31,30	38,0	10	16	20	—	6	12	0,032	
16 T2,5/44-2	44	6F	Al	35,02	34,50	42,0	10	16	24	—	6	14	0,040	
16 T2,5/48-0	48	6	Al	38,20	37,70	—	10	16	26	—	6	15	0,048	
16 T2,5/60-0	60	6	Al	47,75	47,25	—	10	16	34	—	8	18	0,073	



Al = Aluminium

Fertigungstechnische Änderungen vorbehalten. *We reserve the right to make technical changes.*

Metrische Zahnscheiben für zylindrische Bohrung Metric timing belt pulleys for plain boring

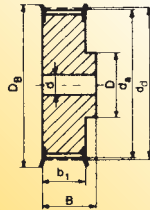

Ausf. Type 6F

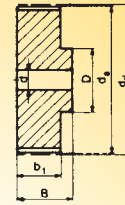

Ausf. Type 6

Type T5 – Teilung *Pitch* 5 mm für Riemenbreite *for belt width* 10 mm

Bezeichnung Part No.	Anzahl der Zähne No. of teeth	Aus- führung Type	Material	d _d (mm)	d _s (mm)	D _B (mm)	b ₁ (mm)	B (mm)	D (mm)	D ₁ (mm)	Vor- bohrung Pilot bore d (mm)	Fertig- bohrung Finished bore d _{max} (mm)	Gewicht Weight (≈ kg)	€ Stück each
21 T5/10-2	10	6F	Al	15,92	15,05	19,5	15	21	8	—	—	5	0,012	auf Anfrage on request
21 T5/12-2	12	6F	Al	19,01	18,25	23,0	15	21	10	—	—	6	0,016	
21 T5/14-2	14	6F	Al	22,29	21,45	25,0	15	21	13	—	—	8	0,019	
21 T5/15-2	15	6F	Al	23,88	23,05	28,0	15	21	16	—	6	10	0,021	
21 T5/16-2	16	6F	Al	25,47	24,60	32,0	15	21	18	—	6	11	0,025	
21 T5/18-2	18	6F	Al	28,65	27,80	32,0	15	21	19	—	6	12	0,031	
21 T5/19-2	19	6F	Al	30,25	29,40	36,0	15	21	22	—	6	12	0,036	
21 T5/20-2	20	6F	Al	31,83	31,00	36,0	15	21	23	—	6	14	0,038	
21 T5/22-2	22	6F	Al	35,12	34,25	38,0	15	21	24	—	6	15	0,046	
21 T5/24-2	24	6F	Al	38,21	37,40	42,0	15	21	26	—	6	15	0,054	
21 T5/25-2	25	6F	Al	39,80	39,00	44,0	15	21	26	—	6	15	0,058	
21 T5/26-2	26	6F	Al	41,47	40,60	44,0	15	21	26	—	6	16	0,062	
21 T5/27-2	27	6F	Al	42,98	42,20	48,0	15	21	30	—	8	18	0,064	
21 T5/28-2	28	6F	Al	44,62	43,75	48,0	15	21	32	—	8	18	0,071	
21 T5/30-2	30	6F	Al	47,76	46,95	51,0	15	21	34	—	8	18	0,075	
21 T5/32-2	32	6F	Al	50,94	50,10	54,0	15	21	38	—	8	22	0,088	
21 T5/36-2	36	6F	Al	57,31	56,45	63,0	15	21	38	—	8	22	0,114	
21 T5/40-2	40	6F	Al	63,66	62,85	66,0	15	21	40	—	8	23	0,138	
21 T5/42-2	42	6F	Al	66,87	66,00	71,0	15	21	40	—	8	24	0,180	
21 T5/44-0	44	6	Al	70,07	69,20	—	15	21	45	—	8	26	0,185	
21 T5/48-0	48	6	Al	76,42	75,55	—	15	21	50	—	8	28	0,200	
21 T5/60-0	60	6	Al	95,52	94,65	—	15	21	65	—	8	35	0,307	

Type T5 – Teilung *Pitch* 5 mm für Riemenbreite *for belt width* 16 mm

27 T5/10-2	10	6F	Al	15,92	15,05	19,5	21	27	8	—	—	5	0,016	auf Anfrage on request
27 T5/12-2	12	6F	Al	19,01	18,25	23,0	21	27	10	—	—	6	0,022	
27 T5/14-2	14	6F	Al	22,29	21,45	25,0	21	27	13	—	—	8	0,026	
27 T5/15-2	15	6F	Al	23,88	23,05	28,0	21	27	16	—	6	10	0,029	
27 T5/16-2	16	6F	Al	25,47	24,60	32,0	21	27	18	—	6	11	0,035	
27 T5/18-2	18	6F	Al	28,65	27,80	32,0	21	27	19	—	6	12	0,043	
27 T5/19-2	19	6F	Al	30,25	29,40	36,0	21	27	22	—	6	12	0,049	
27 T5/20-2	20	6F	Al	31,83	31,00	36,0	21	27	23	—	6	14	0,053	
27 T5/22-2	22	6F	Al	35,12	34,25	38,0	21	27	24	—	6	15	0,054	
27 T5/24-2	24	6F	Al	38,21	37,40	42,0	21	27	26	—	6	15	0,076	
27 T5/25-2	25	6F	Al	39,80	39,00	44,0	21	27	26	—	6	15	0,081	
27 T5/26-2	26	6F	Al	41,47	40,60	44,0	21	27	26	—	6	16	0,085	
27 T5/27-2	27	6F	Al	42,98	42,20	48,0	21	27	30	—	8	18	0,090	
27 T5/28-2	28	6F	Al	44,62	43,75	48,0	21	27	32	—	8	18	0,092	
27 T5/30-2	30	6F	Al	47,76	46,95	51,0	21	27	34	—	8	18	0,105	
27 T5/32-2	32	6F	Al	50,94	50,10	54,0	21	27	38	—	8	22	0,123	
27 T5/36-2	36	6F	Al	57,31	56,45	63,0	21	27	38	—	8	22	0,160	
27 T5/40-2	40	6F	Al	63,66	62,85	66,0	21	27	40	—	8	23	0,193	
27 T5/42-2	42	6F	Al	66,87	66,00	71,0	21	27	40	—	8	24	0,205	
27 T5/44-0	44	6	Al	70,07	69,20	—	21	27	45	—	8	26	0,228	
27 T5/48-0	48	6	Al	76,42	75,55	—	21	27	50	—	8	28	0,280	
27 T5/60-0	60	6	Al	95,52	94,65	—	21	27	65	—	8	35	0,430	

Metrische Zahnscheiben für zylindrische Bohrung

Metric timing belt pulleys for plain boring

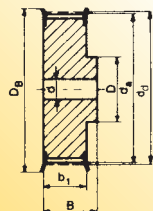

Ausf. Type 6F

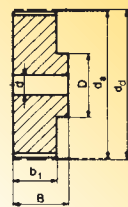

Ausf. Type 6

Type T5 – Teilung Pitch 5 mm für Riemenbreite for belt width 25 mm

Bezeichnung Part No.	Anzahl der Zähne No. of teeth	Aus- führung Type	Material	d _d (mm)	d _s (mm)	D _B (mm)	b ₁ (mm)	B (mm)	D (mm)	D _i (mm)	Vor- bohrung Pilot bore d (mm)	Fertig- bohrung Finished bore d _{max} (mm)	Gewicht Weight (≈ kg)	€ Stück each
36 T5/10-2	10	6F	Al	15,92	15,05	19,5	30	36	8	—	—	5	0,023	auf Anfrage on request
36 T5/12-2	12	6F	Al	19,01	18,25	23,0	30	36	10	—	—	6	0,031	
36 T5/14-2	14	6F	Al	22,29	21,45	25,0	30	36	13	—	—	8	0,037	
36 T5/15-2	15	6F	Al	23,88	23,05	28,0	30	36	16	—	6	10	0,041	
36 T5/16-2	16	6F	Al	25,47	24,60	32,0	30	36	18	—	6	11	0,050	
36 T5/18-2	18	6F	Al	28,65	27,80	32,0	30	36	19	—	6	12	0,061	
36 T5/19-2	19	6F	Al	30,25	29,40	36,0	30	36	22	—	6	12	0,070	
36 T5/20-2	20	6F	Al	31,83	31,00	36,0	30	36	23	—	6	14	0,076	
36 T5/22-2	22	6F	Al	35,12	34,25	38,0	30	36	24	—	6	15	0,080	
36 T5/24-2	24	6F	Al	38,21	37,40	42,0	30	36	26	—	8	15	0,109	
36 T5/25-2	25	6F	Al	39,80	39,00	44,0	30	36	26	—	8	15	0,116	
36 T5/26-2	26	6F	Al	41,47	40,60	44,0	30	36	26	—	8	16	0,120	
36 T5/27-2	27	6F	Al	42,98	42,20	48,0	30	36	30	—	8	18	0,128	
36 T5/28-2	28	6F	Al	44,62	43,75	48,0	30	36	32	—	8	18	0,135	
36 T5/30-2	30	6F	Al	47,76	46,95	51,0	30	36	34	—	8	18	0,150	
36 T5/32-2	32	6F	Al	50,94	50,10	54,0	30	36	38	—	8	22	0,176	
36 T5/36-2	36	6F	Al	57,31	56,45	63,0	30	36	38	—	8	22	0,230	
36 T5/40-2	40	6F	Al	63,66	62,85	66,0	30	36	40	—	8	23	0,276	
36 T5/42-2	42	6F	Al	66,87	66,00	71,0	30	36	40	—	8	24	0,284	
36 T5/44-0	44	6	Al	70,07	69,20	—	30	36	45	—	8	26	0,315	
36 T5/48-0	48	6	Al	76,42	75,55	—	30	36	50	—	8	28	0,400	
36 T5/60-0	60	6	Al	95,52	94,65	—	30	36	65	—	8	35	0,614	

Al = Aluminium

Fertigungstechnische Änderungen vorbehalten. We reserve the right to make technical changes.

Metrische Zahnscheiben für zylindrische Bohrung Metric timing belt pulleys for plain boring

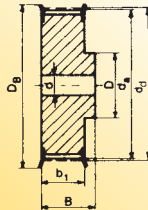

Ausf. Type 6F

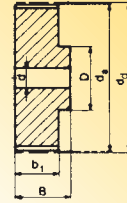

Ausf. Type 6

Type T10 – Teilung *Pitch* 10 mm für Riemenbreite *for belt width* 16 mm

Bezeichnung Part No.	Anzahl der Zähne No. of teeth	Aus- führung Type	Material	d _d (mm)	d _s (mm)	D _B (mm)	b ₁ (mm)	B (mm)	D (mm)	D ₁ (mm)	Vor- bohrung Pilot bore d (mm)	Fertig- bohrung Finished bore d _{max} (mm)	Gewicht Weight (≈ kg)	€ Stück each
31 T10/12-2	12	6F	Al	38,20	36,35	42	21	31	28	—	6	16	0,076	auf Anfrage on request
31 T10/14-2	14	6F	Al	44,56	42,70	48	21	31	32	—	8	18	0,104	
31 T10/15-2	15	6F	Al	47,75	45,90	51	21	31	32	—	8	18	0,116	
31 T10/16-2	16	6F	Al	50,93	49,05	54	21	31	35	—	8	20	0,134	
31 T10/18-2	18	6F	Al	57,29	55,45	60	21	31	40	—	8	22	0,167	
31 T10/19-2	19	6F	Al	60,48	58,60	66	21	31	44	—	8	22	0,184	
31 T10/20-2	20	6F	Al	63,66	61,80	66	21	31	46	—	8	24	0,208	
31 T10/22-2	22	6F	Al	70,03	68,15	75	21	31	52	—	8	28	0,253	
31 T10/24-2	24	6F	Al	76,39	74,55	83	21	31	58	—	8	30	0,288	
31 T10/25-2	25	6F	Al	79,58	77,70	83	21	31	60	—	8	30	0,310	
31 T10/26-2	26	6F	Al	82,76	80,90	87	21	31	60	—	8	30	0,357	
31 T10/27-2	27	6F	Al	85,95	84,10	91	21	31	60	—	8	30	0,364	
31 T10/28-2	28	6F	Al	89,13	87,25	93	21	31	60	—	8	30	0,401	
31 T10/30-2	30	6F	Al	95,49	93,65	97	21	31	60	—	8	30	0,441	
31 T10/32-2	32	6F	Al	101,86	100,00	106	21	31	65	—	10	32	0,493	
31 T10/36-2	36	6F	Al	114,59	112,75	119	21	31	70	—	10	35	0,623	
31 T10/40-2	40	6F	Al	127,32	125,45	131	21	31	80	—	10	40	0,767	
31 T10/44-0	44	6	Al	140,06	138,20	—	21	31	88	—	10	46	0,993	
31 T10/48-0	48	6	Al	152,78	150,95	—	21	31	95	—	16	48	1,090	
31 T10/60-0	60	6	Al	190,98	189,10	—	21	31	110	—	16	60	1,710	

Type T10 – Teilung *Pitch* 10 mm für Riemenbreite *for belt width* 25 mm

40 T10/12-2	12	6F	Al	38,20	36,35	42	30	40	28	—	6	16	0,099	auf Anfrage on request
40 T10/14-2	14	6F	Al	44,56	42,70	48	30	40	32	—	8	18	0,134	
40 T10/15-2	15	6F	Al	47,75	45,90	51	30	40	32	—	8	18	0,152	
40 T10/16-2	16	6F	Al	50,93	49,05	54	30	40	35	—	8	20	0,176	
40 T10/18-2	18	6F	Al	57,29	55,45	60	30	40	40	—	8	22	0,224	
40 T10/19-2	19	6F	Al	60,48	58,60	66	30	40	44	—	8	22	0,247	
40 T10/20-2	20	6F	Al	63,66	61,80	66	30	40	46	—	8	24	0,276	
40 T10/22-2	22	6F	Al	70,03	68,15	75	30	40	52	—	8	28	0,337	
40 T10/24-2	24	6F	Al	76,39	74,55	83	30	40	58	—	8	30	0,392	
40 T10/25-2	25	6F	Al	79,58	77,70	83	30	40	60	—	8	30	0,422	
40 T10/26-2	26	6F	Al	82,76	80,90	87	30	40	60	—	8	30	0,477	
40 T10/27-2	27	6F	Al	85,95	84,10	91	30	40	60	—	8	30	0,536	
40 T10/28-2	28	6F	Al	89,13	87,25	93	30	40	60	—	8	30	0,540	
40 T10/30-2	30	6F	Al	95,49	93,65	97	30	40	60	—	8	30	0,640	
40 T10/32-2	32	6F	Al	101,86	100,00	106	30	40	65	—	10	32	0,693	
40 T10/36-2	36	6F	Al	114,59	112,75	119	30	40	70	—	10	35	0,873	
40 T10/40-2	40	6F	Al	127,32	125,45	131	30	40	80	—	10	40	1,067	
40 T10/44-0	44	6	Al	140,06	138,20	—	30	40	88	—	10	46	1,350	
40 T10/48-0	48	6	Al	152,78	150,95	—	30	40	95	—	16	48	1,516	
40 T10/60-0	60	6	Al	190,98	189,10	—	30	40	110	—	16	60	2,339	

Metrische Zahnscheiben für zylindrische Bohrung Metric timing belt pulleys for plain boring

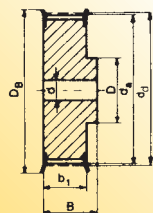

Ausf. Type 6F

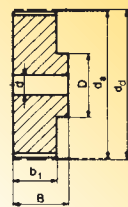

Ausf. Type 6

Type T10 – Teilung Pitch 10 mm für Riemenbreite for belt width 32 mm

Bezeichnung Part No.	Anzahl der Zähne No. of teeth	Aus- führung Type	Material	d _d (mm)	d _s (mm)	D _B (mm)	b ₁ (mm)	B (mm)	D (mm)	D _i (mm)	Vor- bohrung Pilot bore d (mm)	Fertig- bohrung Finished bore d _{max} (mm)	Gewicht Weight (≈ kg)	€ Stück each
47 T10/18-2	18	6F	Al	57,29	55,45	60	37	47	40	—	10	22	0,253	auf Anfrage on request
47 T10/19-2	19	6F	Al	60,48	58,60	66	37	47	44	—	10	22	0,286	
47 T10/20-2	20	6F	Al	63,66	61,80	66	37	47	46	—	12	24	0,322	
47 T10/22-2	22	6F	Al	70,03	68,15	75	37	47	52	—	12	28	0,393	
47 T10/24-2	24	6F	Al	76,39	74,55	83	37	47	58	—	12	30	0,475	
47 T10/25-2	25	6F	Al	79,58	77,70	83	37	47	60	—	12	30	0,527	
47 T10/26-2	26	6F	Al	82,76	80,90	87	37	47	60	—	12	30	0,564	
47 T10/27-2	27	6F	Al	85,95	84,10	91	37	47	60	—	12	30	0,602	
47 T10/28-2	28	6F	Al	89,13	87,25	93	37	47	60	—	12	30	0,642	
47 T10/30-2	30	6F	Al	95,49	93,65	97	37	47	60	—	12	30	0,740	
47 T10/32-2	32	6F	Al	101,86	100,00	106	37	47	65	—	12	32	0,844	
47 T10/36-2	36	6F	Al	114,59	112,75	119	37	47	70	—	16	35	1,083	
47 T10/40-2	40	6F	Al	127,32	125,45	131	37	47	80	—	16	40	1,317	
47 T10/44-0	44	6	Al	140,06	138,20	—	37	47	88	—	16	46	1,611	
47 T10/48-0	48	6	Al	152,78	150,95	—	37	47	95	—	16	48	1,931	
47 T10/60-0	60	6	Al	190,98	189,10	—	37	47	110	—	16	60	3,004	

Type T10 – Teilung Pitch 10 mm für Riemenbreite for belt width 50 mm

66 T10/18-2	18	6F	Al	57,29	55,45	60	56	66	40	—	10	22	0,422	auf Anfrage on request
66 T10/19-2	19	6F	Al	60,48	58,60	66	56	66	44	—	10	22	0,466	
66 T10/20-2	20	6F	Al	63,66	61,80	66	56	66	46	—	12	24	0,520	
66 T10/22-2	22	6F	Al	70,03	68,15	75	56	66	52	—	12	28	0,570	
66 T10/24-2	24	6F	Al	76,39	74,55	83	56	66	58	—	12	30	0,736	
66 T10/25-2	25	6F	Al	79,58	77,70	83	56	66	60	—	12	30	0,766	
66 T10/26-2	26	6F	Al	82,76	80,90	87	56	66	60	—	12	30	0,816	
66 T10/27-2	27	6F	Al	85,95	84,10	91	56	66	60	—	12	30	0,946	
66 T10/28-2	28	6F	Al	89,13	87,25	93	56	66	60	—	12	30	0,960	
66 T10/30-2	30	6F	Al	95,49	93,65	97	56	66	60	—	12	30	1,169	
66 T10/32-2	32	6F	Al	101,86	100,00	106	56	66	65	—	12	32	1,300	
66 T10/36-2	36	6F	Al	114,59	112,75	119	56	66	70	—	16	35	1,637	
66 T10/40-2	40	6F	Al	127,32	125,45	131	56	66	80	—	16	40	1,999	
66 T10/44-0	44	6	Al	140,06	138,20	—	56	66	88	—	16	46	2,357	
66 T10/48-0	48	6	Al	152,78	150,95	—	56	66	95	—	16	48	2,830	
66 T10/60-0	60	6	Al	190,98	189,10	—	56	66	110	—	16	60	4,366	

Al = Aluminium

Fertigungstechnische Änderungen vorbehalten. We reserve the right to make technical changes.

Metrische Zahnscheiben für zylindrische Bohrung Metric timing belt pulleys for plain boring

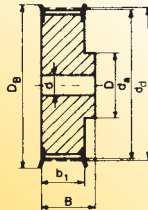

Ausf. Type 6F

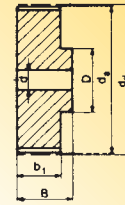

Ausf. Type 6

Type AT5 – Teilung Pitch 5 mm für Riemenbreite for belt width 10 mm

Bezeichnung Part No.	Anzahl der Zähne No. of teeth	Aus- führung Type	Material	d _d (mm)	d _a (mm)	D _B (mm)	b ₁ (mm)	B (mm)	D (mm)	Vor- bohrung Pilot bore d (mm)	Fertig- bohrung Finished bore d _{max} (mm)	Gewicht Weight (≈ kg)	€ Stück each
21 AT5/12-2	12	6F	Al	19,01	17,85	23,0	15	21	10	—	6	0,016	auf Anfrage on request
21 AT5/14-2	14	6F	Al	22,29	21,05	25,0	15	21	13	—	8	0,019	
21 AT5/15-2	15	6F	Al	23,88	22,65	28,0	15	21	16	6	10	0,021	
21 AT5/16-2	16	6F	Al	25,47	24,20	32,0	15	21	18	6	11	0,025	
21 AT5/18-2	18	6F	Al	28,65	27,40	32,0	15	21	19	6	12	0,031	
21 AT5/19-2	19	6F	Al	30,25	29,00	36,0	15	21	22	6	12	0,036	
21 AT5/20-2	20	6F	Al	31,83	30,60	36,0	15	21	23	6	14	0,038	
21 AT5/22-2	22	6F	Al	35,12	33,85	38,0	15	21	24	6	15	0,046	
21 AT5/24-2	24	6F	Al	38,21	37,00	42,0	15	21	26	6	15	0,054	
21 AT5/25-2	25	6F	Al	39,80	38,60	44,0	15	21	26	6	15	0,058	
21 AT5/26-2	26	6F	Al	41,47	40,20	44,0	15	21	26	6	16	0,062	
21 AT5/27-2	27	6F	Al	42,98	41,80	48,0	15	21	30	8	18	0,064	
21 AT5/28-2	28	6F	Al	44,62	43,35	48,0	15	21	32	8	18	0,071	
21 AT5/30-2	30	6F	Al	47,76	46,55	51,0	15	21	34	8	18	0,075	
21 AT5/32-2	32	6F	Al	50,94	49,70	54,0	15	21	38	8	22	0,088	
21 AT5/36-2	36	6F	Al	57,31	56,05	63,0	15	21	38	8	22	0,114	
21 AT5/40-2	40	6F	Al	63,66	62,45	66,0	15	21	40	8	23	0,138	
21 AT5/42-2	42	6F	Al	66,87	65,60	71,0	15	21	40	8	24	0,180	
21 AT5/44-0	44	6	Al	70,07	68,80	—	15	21	45	8	26	0,185	
21 AT5/48-0	48	6	Al	76,42	75,15	—	15	21	50	8	28	0,200	
21 AT5/60-0	60	6	Al	95,52	94,25	—	15	21	65	8	35	0,307	

Type AT5 – Teilung Pitch 5 mm für Riemenbreite for belt width 16 mm

27 AT5/12-2	12	6F	Al	19,01	17,85	23,0	21	27	10	—	6	0,022	auf Anfrage on request
27 AT5/14-2	14	6F	Al	22,29	21,05	25,0	21	27	13	—	8	0,026	
27 AT5/15-2	15	6F	Al	23,88	22,65	28,0	21	27	16	6	10	0,029	
27 AT5/16-2	16	6F	Al	25,47	24,20	32,0	21	27	18	6	11	0,035	
27 AT5/18-2	18	6F	Al	28,65	27,40	32,0	21	27	19	6	12	0,043	
27 AT5/19-2	19	6F	Al	30,25	29,00	36,0	21	27	22	6	12	0,049	
27 AT5/20-2	20	6F	Al	31,83	30,60	36,0	21	27	23	6	14	0,053	
27 AT5/22-2	22	6F	Al	35,12	33,85	38,0	21	27	24	6	15	0,054	
27 AT5/24-2	24	6F	Al	38,21	37,00	42,0	21	27	26	6	15	0,076	
27 AT5/25-2	25	6F	Al	39,80	38,60	44,0	21	27	26	6	15	0,081	
27 AT5/26-2	26	6F	Al	41,47	40,20	44,0	21	27	26	6	16	0,085	
27 AT5/27-2	27	6F	Al	42,98	41,80	48,0	21	27	30	8	18	0,090	
27 AT5/28-2	28	6F	Al	44,62	43,35	48,0	21	27	32	8	18	0,092	
27 AT5/30-2	30	6F	Al	47,76	46,55	51,0	21	27	34	8	18	0,105	
27 AT5/32-2	32	6F	Al	50,94	49,70	54,0	21	27	38	8	22	0,123	
27 AT5/36-2	36	6F	Al	57,31	56,05	63,0	21	27	38	8	22	0,160	
27 AT5/40-2	40	6F	Al	63,66	62,45	66,0	21	27	40	8	23	0,193	
27 AT5/42-2	42	6F	Al	66,87	65,60	71,0	21	27	40	8	24	0,205	
27 AT5/44-0	44	6	Al	70,07	68,80	—	21	27	45	8	26	0,228	
27 AT5/48-0	48	6	Al	76,42	75,15	—	21	27	50	8	28	0,280	
27 AT5/60-0	60	6	Al	95,52	94,25	—	21	27	65	8	35	0,430	

Al = Aluminium

Fertigungstechnische Änderungen vorbehalten. We reserve the right to make technical changes.

Metrische Zahnscheiben für zylindrische Bohrung

Metric timing belt pulleys for plain boring

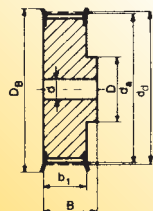

Ausf. Type 6F

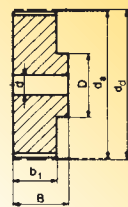

Ausf. Type 6

Type AT5 – Teilung *Pitch* 5 mm für Riemenbreite *for belt width* 25 mm

Bezeichnung Part No.	Anzahl der Zähne No. of teeth	Aus- führung Type	Material	d_d (mm)	d_s (mm)	D_B (mm)	b_1 (mm)	B (mm)	D (mm)	Vor- bohrung Pilot bore d (mm)	Fertig- bohrung Finished bore d_{max} (mm)	Gewicht Weight (≈ kg)	€ Stück each
36 AT5/12-2	12	6F	Al	19,01	17,85	23,0	30	36	10	—	6	0,031	auf Anfrage on request
36 AT5/14-2	14	6F	Al	22,29	21,05	25,0	30	36	13	—	8	0,037	
36 AT5/15-2	15	6F	Al	23,88	22,65	28,0	30	36	16	6	10	0,041	
36 AT5/16-2	16	6F	Al	25,47	24,20	32,0	30	36	18	6	11	0,050	
36 AT5/18-2	18	6F	Al	28,65	27,40	32,0	30	36	19	6	12	0,061	
36 AT5/19-2	19	6F	Al	30,25	29,00	36,0	30	36	22	6	12	0,070	
36 AT5/20-2	20	6F	Al	31,83	30,60	36,0	30	36	23	6	14	0,076	
36 AT5/22-2	22	6F	Al	35,12	33,85	38,0	30	36	24	6	15	0,080	
36 AT5/24-2	24	6F	Al	38,21	37,00	42,0	30	36	26	8	15	0,109	
36 AT5/25-2	25	6F	Al	39,80	38,60	44,0	30	36	26	8	15	0,116	
36 AT5/26-2	26	6F	Al	41,47	40,20	44,0	30	36	26	8	16	0,120	
36 AT5/27-2	27	6F	Al	42,98	41,80	48,0	30	36	30	8	18	0,128	
36 AT5/28-2	28	6F	Al	44,62	43,35	48,0	30	36	32	8	18	0,135	
36 AT5/30-2	30	6F	Al	47,76	46,55	51,0	30	36	34	8	18	0,150	
36 AT5/32-2	32	6F	Al	50,94	49,70	54,0	30	36	38	8	22	0,176	
36 AT5/36-2	36	6F	Al	57,31	56,05	63,0	30	36	38	8	22	0,230	
36 AT5/40-2	40	6F	Al	63,66	62,45	66,0	30	36	40	8	23	0,276	
36 AT5/42-2	42	6F	Al	66,87	65,60	71,0	30	36	40	8	24	0,284	
36 AT5/44-0	44	6	Al	70,07	68,80	—	30	36	45	8	26	0,315	
36 AT5/48-0	48	6	Al	76,42	75,15	—	30	36	50	8	28	0,400	
36 AT5/60-0	60	6	Al	95,52	94,25	—	30	36	65	8	35	0,614	

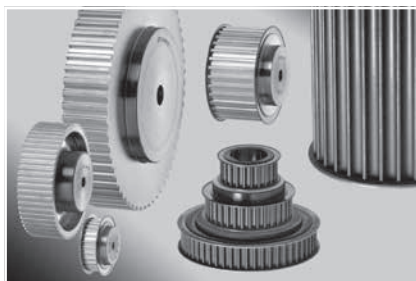

Al = Aluminium

Fertigungstechnische Änderungen vorbehalten. *We reserve the right to make technical changes.*

Metrische Zahnscheiben für zylindrische Bohrung Metric timing belt pulleys for plain boring

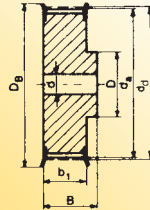

Ausf. Type 6F

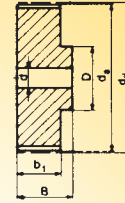

Ausf. Type 6

Type AT10 – Teilung Pitch 10 mm für Riemenbreite for belt width 16 mm

Bezeichnung Part No.	Anzahl der Zähne No. of teeth	Aus- führung Type	Material	d _d (mm)	d _a (mm)	D _B (mm)	b ₁ (mm)	B (mm)	D (mm)	Vor- bohrung Pilot bore d (mm)	Fertig- bohrung Finished bore d _{max} (mm)	Gewicht Weight (≈ kg)	€ Stück each
31 AT10/15-2	15	6F	Al	47,75	45,90	51	21	31	32	8	18	0,116	auf Anfrage on request
31 AT10/16-2	16	6F	Al	50,93	49,05	54	21	31	35	8	20	0,134	
31 AT10/18-2	18	6F	Al	57,29	55,45	60	21	31	40	8	22	0,167	
31 AT10/19-2	19	6F	Al	60,48	58,60	66	21	31	44	8	22	0,184	
31 AT10/20-2	20	6F	Al	63,66	61,80	66	21	31	46	8	24	0,208	
31 AT10/22-2	22	6F	Al	70,03	68,15	75	21	31	52	8	28	0,253	
31 AT10/24-2	24	6F	Al	76,39	74,55	83	21	31	58	8	30	0,288	
31 AT10/25-2	25	6F	Al	79,58	77,70	83	21	31	60	8	30	0,310	
31 AT10/26-2	26	6F	Al	82,76	80,90	87	21	31	60	8	30	0,357	
31 AT10/27-2	27	6F	Al	85,95	84,10	91	21	31	60	8	30	0,364	
31 AT10/28-2	28	6F	Al	89,13	87,25	93	21	31	60	8	30	0,401	
31 AT10/30-2	30	6F	Al	95,49	93,65	97	21	31	60	8	30	0,441	
31 AT10/32-2	32	6F	Al	101,86	100,00	106	21	31	65	10	32	0,493	
31 AT10/36-2	36	6F	Al	114,59	112,75	119	21	31	70	10	35	0,623	
31 AT10/40-2	40	6F	Al	127,32	125,45	131	21	31	80	10	40	0,767	
31 AT10/44-0	44	6	Al	140,06	138,20	—	21	31	88	10	46	0,993	
31 AT10/48-0	48	6	Al	152,78	150,95	—	21	31	95	16	48	1,090	
31 AT10/60-0	60	6	Al	190,98	189,10	—	21	31	110	16	60	1,710	

Type AT10 – Teilung Pitch 10 mm für Riemenbreite for belt width 25 mm

40 AT10/15-2	15	6F	Al	47,75	45,90	51	30	40	32	8	18	0,152	auf Anfrage on request
40 AT10/16-2	16	6F	Al	50,93	49,05	54	30	40	35	8	20	0,176	
40 AT10/18-2	18	6F	Al	57,29	55,45	60	30	40	40	8	22	0,224	
40 AT10/19-2	19	6F	Al	60,48	58,60	66	30	40	44	8	22	0,247	
40 AT10/20-2	20	6F	Al	63,66	61,80	66	30	40	46	8	24	0,276	
40 AT10/22-2	22	6F	Al	70,03	68,15	75	30	40	52	8	28	0,337	
40 AT10/24-2	24	6F	Al	76,39	74,55	83	30	40	58	8	30	0,392	
40 AT10/25-2	25	6F	Al	79,58	77,70	83	30	40	60	8	30	0,422	
40 AT10/26-2	26	6F	Al	82,76	80,90	87	30	40	60	8	30	0,477	
40 AT10/27-2	27	6F	Al	85,95	84,10	91	30	40	60	8	30	0,536	
40 AT10/28-2	28	6F	Al	89,13	87,25	93	30	40	60	8	30	0,540	
40 AT10/30-2	30	6F	Al	95,49	93,65	97	30	40	60	8	30	0,640	
40 AT10/32-2	32	6F	Al	101,86	100,00	106	30	40	65	10	32	0,693	
40 AT10/36-2	36	6F	Al	114,59	112,75	119	30	40	70	10	35	0,873	
40 AT10/40-2	40	6F	Al	127,32	125,45	131	30	40	80	10	40	1,067	
40 AT10/44-0	44	6	Al	140,06	138,20	—	30	40	88	10	46	1,350	
40 AT10/48-0	48	6	Al	152,78	150,95	—	30	40	95	16	48	1,516	
40 AT10/60-0	60	6	Al	190,98	189,10	—	30	40	110	16	60	2,339	

Metrische Zahnscheiben für zylindrische Bohrung Metric timing belt pulleys for plain boring

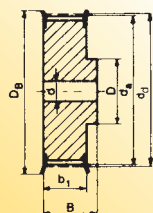

Ausf. Type 6F

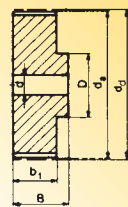

Ausf. Type 6

Type AT10 – Teilung *Pitch* 10 mm für Riemenbreite *for belt width* 32 mm

Bezeichnung Part No.	Anzahl der Zähne No. of teeth	Aus- führung Type	Material	d_d (mm)	d_s (mm)	D_B (mm)	b_1 (mm)	B (mm)	D (mm)	Vor- bohrung Pilot bore d (mm)	Fertig- bohrung Finished bore d_{max} (mm)	Gewicht Weight (≈ kg)	€ Stück each
47 AT10/18-2	18	6F	Al	57,29	55,45	60	37	47	40	10	22	0,253	auf Anfrage on request
47 AT10/19-2	19	6F	Al	60,48	58,60	66	37	47	44	10	22	0,286	
47 AT10/20-2	20	6F	Al	63,66	61,80	66	37	47	46	12	24	0,322	
47 AT10/22-2	22	6F	Al	70,03	68,15	75	37	47	52	12	28	0,393	
47 AT10/24-2	24	6F	Al	76,39	74,55	83	37	47	58	12	30	0,475	
47 AT10/25-2	25	6F	Al	79,58	77,70	83	37	47	60	12	30	0,527	
47 AT10/26-2	26	6F	Al	82,76	80,90	87	37	47	60	12	30	0,564	
47 AT10/27-2	27	6F	Al	85,95	84,10	91	37	47	60	12	30	0,602	
47 AT10/28-2	28	6F	Al	89,13	87,25	93	37	47	60	12	30	0,642	
47 AT10/30-2	30	6F	Al	95,49	93,65	97	37	47	60	12	30	0,740	
47 AT10/32-2	32	6F	Al	101,86	100,00	106	37	47	65	12	32	0,844	
47 AT10/36-2	36	6F	Al	114,59	112,75	119	37	47	70	16	35	1,083	
47 AT10/40-2	40	6F	Al	127,32	125,45	131	37	47	80	16	40	1,317	
47 AT10/44-0	44	6	Al	140,06	138,20	—	37	47	88	16	46	1,611	
47 AT10/48-0	48	6	Al	152,78	150,95	—	37	47	95	16	48	1,931	
47 AT10/60-0	60	6	Al	190,98	189,10	—	37	47	110	16	60	3,004	

Type AT10 – Teilung *Pitch* 10 mm für Riemenbreite *for belt width* 50 mm

66 AT10/18-2	18	6F	Al	57,29	55,45	60	56	66	40	10	22	0,422	auf Anfrage on request
66 AT10/19-2	19	6F	Al	60,48	58,60	66	56	66	44	10	22	0,466	
66 AT10/20-2	20	6F	Al	63,66	61,80	66	56	66	46	12	24	0,520	
66 AT10/22-2	22	6F	Al	70,03	68,15	75	56	66	52	12	28	0,570	
66 AT10/24-2	24	6F	Al	76,39	74,55	83	56	66	58	12	30	0,736	
66 AT10/25-2	25	6F	Al	79,58	77,70	83	56	66	60	12	30	0,766	
66 AT10/26-2	26	6F	Al	82,76	80,90	87	56	66	60	12	30	0,816	
66 AT10/27-2	27	6F	Al	85,95	84,10	91	56	66	60	12	30	0,946	
66 AT10/28-2	28	6F	Al	89,13	87,25	93	56	66	60	12	30	0,960	
66 AT10/30-2	30	6F	Al	95,49	93,65	97	56	66	60	12	30	1,169	
66 AT10/32-2	32	6F	Al	101,86	100,00	106	56	66	65	12	32	1,300	
66 AT10/36-2	36	6F	Al	114,59	112,75	119	56	66	70	16	35	1,637	
66 AT10/40-2	40	6F	Al	127,32	125,45	131	56	66	80	16	40	1,999	
66 AT10/44-0	44	6	Al	140,06	138,20	—	56	66	88	16	46	2,357	
66 AT10/48-0	48	6	Al	152,78	150,95	—	56	66	95	16	48	2,830	
66 AT10/60-0	60	6	Al	190,98	189,10	—	56	66	110	16	60	4,366	

Al = Aluminium

Fertigungstechnische Änderungen vorbehalten. *We reserve the right to make technical changes.*

Standard-Zahnwellen

Timing bars – standard timing belts

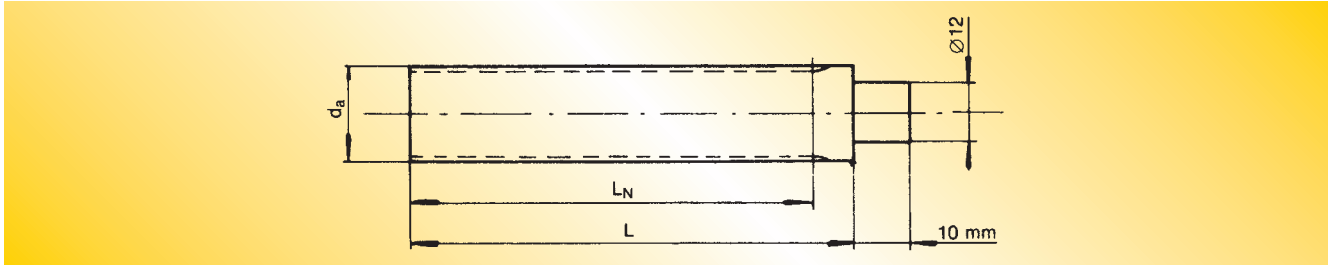

Type XL – Teilung *Pitch 5,08 mm (1/5")*

Bezeichnung Part No.	Anzahl der Zähne No. of teeth	Material	d_d (mm)	d_a (mm)	L_N (mm)	L (mm)	€ Stück each
10 XL 125	10	St	16,17	15,66	125	140	auf Anfrage on request
11 XL 125	11	St	17,79	17,28	125	140	
12 XL 125	12	St	19,40	18,89	125	140	
13 XL 125	13	St	21,02	20,51	125	140	
14 XL 132	14	St	22,64	22,13	132	140	
15 XL 132	15	St	24,26	23,75	132	140	
16 XL 140	16	St	25,87	25,36	140	140	
17 XL 140	17	St	27,49	26,98	140	140	
18 XL 140	18	St	29,11	28,60	140	140	
19 XL 140	19	St	30,72	30,21	140	140	
20 XL 140	20	St	32,34	31,83	140	140	
21 XL 160	21	St	33,96	33,45	160	160	
22 XL 160	22	St	35,57	35,06	160	160	
23 XL 160	23	St	37,19	36,68	160	160	
24 XL 160	24	St	38,81	38,30	160	160	
25 XL 160	25	St	40,43	39,92	160	160	
26 XL 160	26	St	42,04	41,53	160	160	
27 XL 160	27	St	43,66	43,15	160	160	
28 XL 160	28	St	45,28	44,77	160	160	
29 XL 160	29	St	46,89	46,38	160	160	
30 XL 160	30	St	48,51	48,00	160	160	
32 XL 160	32	Al	51,74	51,23	160	160	
33 XL 160	33	Al	53,36	52,76	160	160	
34 XL 160	34	Al	54,98	54,47	160	160	
35 XL 160	35	Al	56,60	56,09	160	160	
36 XL 160	36	Al	58,21	57,70	160	160	
38 XL 160	38	Al	61,45	60,94	160	160	
39 XL 160	39	Al	63,06	62,55	160	160	
40 XL 160	40	Al	64,68	64,17	160	160	
41 XL 160	41	Al	66,30	65,79	160	160	
42 XL 160	42	Al	67,91	67,40	160	160	
43 XL 160	43	Al	69,53	69,02	160	160	
44 XL 160	44	Al	71,15	70,64	160	160	
48 XL 160	48	Al	77,62	77,11	160	160	
56 XL 160	56	Al	90,55	90,04	160	160	
60 XL 160	60	Al	97,02	96,51	160	160	
72 XL 160	72	Al	116,43	115,92	160	160	

Standard-Zahnwellen Timing bars – standard timing belts

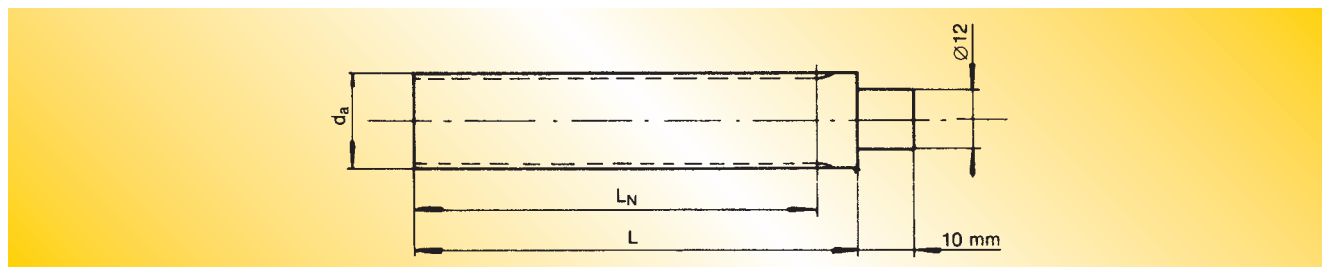

Type L – Teilung *Pitch* 9,525 mm ($\frac{3}{8}$ ")

Bezeichnung Part No.	Anzahl der Zähne No. of teeth	Material	d_d (mm)	d_s (mm)	L_N (mm)	L (mm)	€ Stück each
10 L 140	10	St	30,32	29,56	140	140	auf Anfrage on request
11 L 140	11	St	33,35	32,59	140	140	
12 L 160	12	St	36,38	35,62	160	160	
13 L 160	13	St	39,41	38,65	160	160	
14 L 160	14	St	42,45	41,68	160	160	
15 L 160	15	St	45,48	44,72	160	160	
16 L 160	16	St	48,51	47,75	160	160	
17 L 160	17	St	51,54	50,78	160	160	
18 L 160	18	St	54,57	53,81	160	160	
19 L 160	19	St	57,61	56,84	160	160	
20 L 160	20	St	60,64	59,88	160	160	
21 L 160	21	St	63,67	62,91	160	160	
22 L 160	22	St	66,70	65,94	160	160	
23 L 160	23	St	69,73	68,97	160	160	
24 L 160	24	St	72,77	72,00	160	160	
27 L 160	27	St	81,86	81,10	160	160	
30 L 160	30	St	90,96	90,20	160	160	

Metrische Zahnwellen Timing bars – metric timing belts

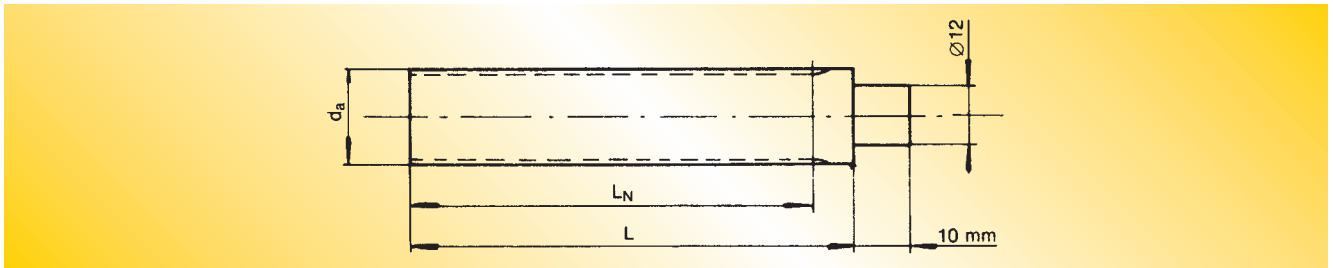

Type T5 – Teilung *Pitch* 5 mm

Bezeichnung Part No.	Anzahl der Zähne No. of teeth	Material	d _d (mm)	d _a (mm)	L _N (mm)	L (mm)	€ Stück each
125 T5- 10	10	Al	15,92	15,05	125	140	auf Anfrage on request
125 T5- 11	11	Al	17,51	16,65	125	140	
125 T5- 12	12	Al	19,01	18,25	125	140	
125 T5- 13	13	Al	20,70	19,85	125	140	
132 T5- 14	14	Al	22,29	21,45	132	140	
132 T5- 15	15	Al	23,88	23,05	132	140	
140 T5- 16	16	Al	25,47	24,60	140	140	
140 T5- 17	17	Al	27,06	26,20	140	140	
140 T5- 18	18	Al	28,65	27,80	140	140	
140 T5- 19	19	Al	30,25	29,40	140	140	
160 T5- 20	20	Al	31,83	31,00	160	160	
160 T5- 21	21	Al	33,43	32,70	160	160	
160 T5- 22	22	Al	35,12	34,25	160	160	
160 T5- 23	23	Al	36,62	35,85	160	160	
160 T5- 24	24	Al	38,21	37,40	160	160	
160 T5- 25	25	Al	39,80	39,00	160	160	
160 T5- 26	26	Al	41,47	40,60	160	160	
160 T5- 27	27	Al	42,98	42,20	160	160	
160 T5- 28	28	Al	44,62	43,75	160	160	
160 T5- 29	29	Al	46,17	45,35	160	160	
160 T5- 30	30	Al	47,76	46,95	160	160	
160 T5- 32	32	Al	50,94	50,10	160	160	
160 T5- 34	34	Al	54,13	53,25	160	160	
160 T5- 35	35	Al	55,72	54,85	160	160	
160 T5- 36	36	Al	57,31	56,45	160	160	
160 T5- 37	37	Al	58,90	58,06	160	160	
160 T5- 38	38	Al	60,50	59,65	160	160	
160 T5- 40	40	Al	63,66	62,85	160	160	
160 T5- 42	42	Al	66,87	66,00	160	160	
160 T5- 44	44	Al	70,07	69,20	160	160	
160 T5- 45	45	Al	71,64	70,80	160	160	
160 T5- 46	46	Al	73,23	72,40	160	160	
160 T5- 48	48	Al	76,42	75,55	160	160	
160 T5- 50	50	Al	79,60	78,75	160	160	
160 T5- 60	60	Al	95,52	94,65	160	160	
160 T5- 72	72	Al	114,62	113,75	160	160	
160 T5- 80	80	Al	127,36	126,48	160	160	
160 T5- 90	90	Al	143,28	142,40	160	160	
160 T5-100	100	Al	159,20	158,31	160	160	

Metrische Zahnwellen

Timing bars – metric timing belts

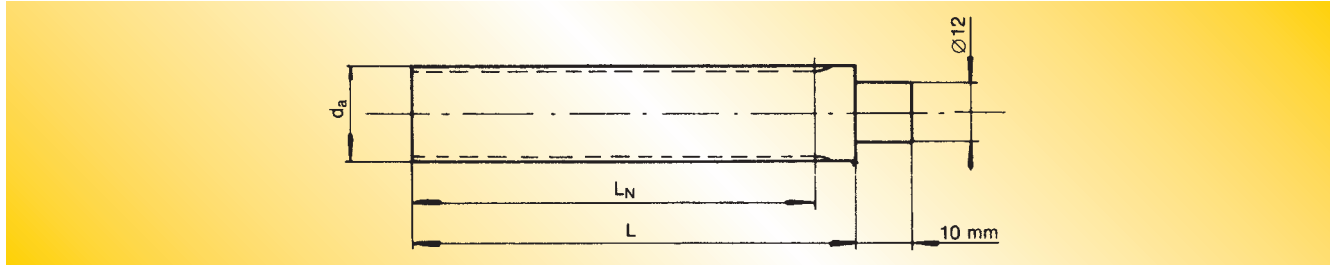

Type T10 – Teilung *Pitch* 10 mm

Bezeichnung Part No.	Anzahl der Zähne No. of teeth	Material	d_d (mm)	d_s (mm)	L_N (mm)	L (mm)	€ Stück each
140 T10-10	10	Al	31,83	29,98	140	140	auf Anfrage on request
140 T10-11	11	Al	35,01	33,16	140	140	
140 T10-12	12	Al	38,20	36,35	140	140	
140 T10-13	13	Al	41,38	39,50	140	140	
160 T10-14	14	Al	44,56	42,70	160	160	
160 T10-15	15	Al	47,75	45,90	160	160	
160 T10-16	16	Al	50,93	49,05	160	160	
160 T10-17	17	Al	54,11	52,25	160	160	
160 T10-18	18	Al	57,29	55,45	160	160	
160 T10-19	19	Al	60,48	58,60	160	160	
160 T10-20	20	Al	63,66	61,60	160	160	
160 T10-21	21	Al	66,84	65,00	160	160	
160 T10-22	22	Al	70,03	68,15	160	160	
160 T10-23	23	Al	73,20	71,35	160	160	
160 T10-24	24	Al	76,39	74,55	160	160	
160 T10-26	26	Al	82,76	80,90	160	160	
160 T10-28	28	Al	89,13	87,25	160	160	
160 T10-30	30	Al	95,49	93,65	160	160	
160 T10-32	32	Al	101,86	100,00	160	160	
160 T10-34	34	Al	108,22	106,40	160	160	
160 T10-36	36	Al	114,59	112,75	160	160	
160 T10-38	38	Al	120,95	119,10	160	160	
160 T10-40	40	Al	127,32	125,45	160	160	
160 T10-45	45	Al	143,24	141,40	160	160	
160 T10-48	48	Al	152,78	150,95	160	160	
160 T10-60	60	Al	190,98	189,10	160	160	
160 T10-72	72	Al	229,18	227,29	160	160	

Kettenräder Sprockets

Kettenräder mit einseitiger Nabe für Simplex-, Duplex- und Triplex-Rollenkette nach DIN 8187 - ISO/R 606
Sprockets for simplex, duplex and triplex chain according to DIN 8187 - ISO/R 606

06B

Kette chain	mm	Kettenräder sprockets	mm
Teilung Pitch	9,525	Radius Tooth radius	r 10
Innere Breite Internal width	5,72	Breite radius width	c 1
Rollen Roller	ø 6,35	Zahnbreite Tooth width	h ₁ 5,3
		Zahnbreite Tooth width	L 5,2
		Zahnbreite Tooth width	h ₂ 15,4
		Zahnbreite Tooth width	h ₃ 25,6
		Gesamthöhe Full height	H —

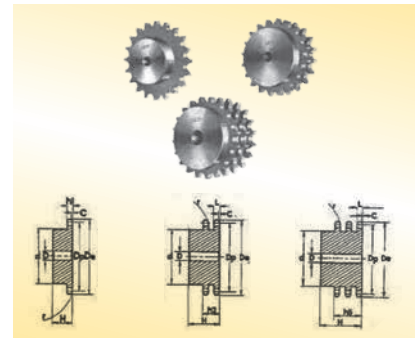

Material C 45 E - UNI EN 10083-1

3/8" x 7/32"

9,525 x 5,72 mm

Z	De	Dp	SIMPLEX			DUPLEX			TRIPLEX			Z	De	Dp	SIMPLEX			DUPLEX			TRIPLEX		
			d	D	H	d	D	H	d	D	H				d	D	H	d	D	H	d	D	H
8	28,0	24,89	15	8	22	15	6	22	15	6	32	25	80,0	76,00	57	12	28	64	12	30	64	14	40
9	31,0	27,85	18	8	22	18	8	22	18	8	32	26	83,0	79,02	60	12	28	67	12	30	67	14	40
10	34,0	30,82	20	8	22	20	8	22	20	10	32	27	86,0	82,04	60	12	28	70	12	30	70	14	40
11	37,0	33,80	22	8	25	22	10	25	22	10	35	28	89,0	85,07	60	12	28	73	12	30	73	14	40
12	40,0	36,80	25	8	25	25	10	25	25	10	35	29	92,0	88,09	60	12	28	76	12	30	76	14	40
13	43,0	39,80	28	10	25	28	10	25	28	10	35	30	94,7	91,12	60	12	30	79	12	30	79	14	40
14	46,3	42,80	31	10	25	31	10	25	31	12	35	31	98,3	94,15	65	14	30	80	16	30	80	16	40
15	49,3	45,81	34	10	25	34	10	25	34	12	35	32	101,3	97,17	65	14	30	80	16	30	80	16	40
16	52,3	48,82	37	10	28	37	12	30	37	12	35	33	104,3	100,20	65	14	30	80	16	30	80	16	40
17	55,3	51,83	40	10	28	40	12	30	40	12	35	34	107,3	103,23	65	14	30	80	16	30	85	16	40
18	58,3	54,85	43	10	28	43	12	30	43	12	35	35	110,4	106,26	65	14	30	80	16	30	85	16	40
19	61,3	57,87	45	10	28	46	12	30	46	12	35	36	113,4	109,29	70	16	30	90	16	30	90	16	40
20	64,3	60,89	46	10	28	49	12	30	49	12	35	37	116,4	112,32	70	16	30	90	16	30	90	16	40
21	68,0	63,91	48	12	28	52	12	30	52	14	40	38	119,5	115,34	70	16	30	90	16	30	90	16	40
22	71,0	66,93	50	12	28	55	12	30	55	14	40	39	122,5	118,37	70	16	30	90	16	30	90	16	40
23	73,5	69,95	52	12	28	58	12	30	58	14	40	40	125,5	121,40	70	16	30	90	16	30	90	16	40
24	77,0	72,97	54	12	28	61	12	30	61	14	40												

Kettenräder Sprockets

Kettenräder mit einseitiger Nabe für Simplex-, Duplex- und Triplex-Rollenkette nach DIN 8187 - ISO/R 606
Sprockets for simplex, duplex and triplex chain according to DIN 8187 - ISO/R 606

08B

Kette chain	mm	Kettenräder sprockets	mm
Teilung Pitch	12,70	Radius Tooth radius	r 13
Innere Breite Internal width	7,75	Breite radius width	c 1,3
Rollen Roller	∅ 8,51	Zahnbreite Tooth width	h ₁ 7,2
		Zahnbreite Tooth width	L 7
		Zahnbreite Tooth width	h ₂ 21
		Zahnbreite Tooth width	h ₃ 34,9
		Gesamthöhe Full height	H —

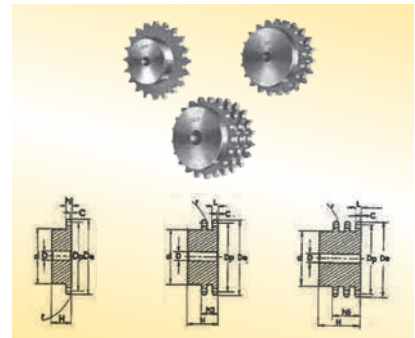

Material C 45 E - UNI EN 10083-1

1/2" x 5/16"

12,7 x 7,75 mm

Z	De	Dp	SIMPLEX			DUPLEX			TRIPLEX			Z	De	Dp	SIMPLEX			DUPLEX			TRIPLEX		
			d	D	H	d	D	H	d	D	H				d	D	H	d	D	H	d	D	H
8	37,2	33,18	20	10	25	20	10	32	20	10	46	25	105,8	101,33	70	14	28	80	16	40	80	20	55
9	41,0	37,13	24	10	25	24	10	32	24	12	46	26	110,0	105,36	70	16	30	85	20	40	85	20	55
10	45,2	41,10	26	10	25	28	10	32	28	12	46	27	114,0	109,40	70	16	30	85	20	40	85	20	55
11	48,7	45,07	29	10	25	32	12	35	32	14	50	28	118,0	113,42	70	16	30	90	20	40	90	20	55
12	53,0	49,07	33	10	28	35	12	35	35	14	50	29	122,0	117,46	80	16	30	95	20	40	95	20	55
13	57,4	53,06	37	10	28	38	12	35	38	14	50	30	126,1	121,50	80	16	30	100	20	40	100	20	55
14	61,8	57,07	41	10	28	42	12	35	42	14	50	31	130,2	125,54	90	16	30	100	20	40	110	20	55
15	65,5	61,09	45	10	28	46	12	35	46	14	50	32	134,3	129,56	90	16	30	100	20	40	110	20	55
16	69,5	65,10	50	12	28	50	14	35	50	16	50	33	138,4	133,60	90	16	30	100	20	40	110	20	55
17	73,6	69,11	52	12	28	54	14	35	54	16	50	34	142,6	137,64	90	16	30	100	20	40	110	20	55
18	77,8	73,14	56	12	28	58	14	35	58	16	50	35	146,7	141,68	90	16	30	100	20	40	110	20	55
19	81,7	77,16	60	12	28	62	14	35	62	16	50	36	151,0	145,72	90	16	35	110	20	40	120	25	55
20	85,8	81,19	64	12	28	66	14	35	66	16	50	37	154,6	149,76	90	16	35	110	20	40	120	25	55
21	89,7	85,22	68	12	28	70	16	40	70	20	55	38	158,6	153,80	90	16	35	110	20	40	120	25	55
22	93,8	89,24	70	12	28	70	16	40	70	20	55	39	162,7	157,83	90	16	35	110	20	40	120	25	55
23	98,2	93,27	70	14	28	70	16	40	70	20	55	40	166,8	161,87	90	16	35	110	20	40	120	25	55
24	101,8	97,29	70	14	28	75	16	40	75	20	55												

Lagerverfügbarkeit der Kettenräder von Z=41 bis Z=125 ist zu prüfen. Availability of sprockets from Z=41 to Z=125 can be checked on demand.

Kettenräder Sprockets

Kettenräder mit einseitiger Nabe für Simplex-, Duplex- und Triplex-Rollenkette nach DIN 8187 - ISO/R 606
Sprockets for simplex, duplex and triplex chain according to DIN 8187 - ISO/R 606

10B

Kette chain	mm	Kettenräder sprockets	mm
Teilung Pitch	15,875	Radius Tooth radius	r 16
Innere Breite Internal width	9,65	Breite radius width	c 1,6
Rollen Roller	∅ 10,16	Zahnbreite Tooth width	h ₁ 9,1
		Zahnbreite Tooth width	L 9
		Zahnbreite Tooth width	h ₂ 25,5
		Zahnbreite Tooth width	h ₃ 42,1
		Gesamthöhe Full height	H —

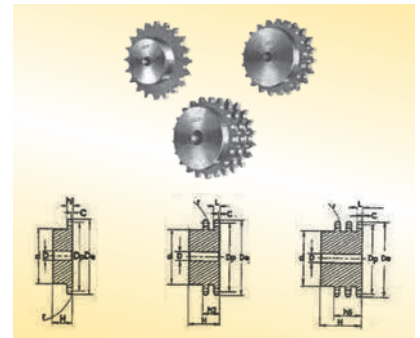

Material C 45 E - UNI EN 10083-1

5/8" x 3/8"

15,875 x 9,65 mm

Z	De	Dp	SIMPLEX			DUPLEX			TRIPLEX			Z	De	Dp	SIMPLEX			DUPLEX			TRIPLEX		
			d	D	H	d	D	H	d	D	H				d	D	H	d	D	H	d	D	H
8	47,0	41,48	25	10	25	25	12	40	25	12	55	25	134,0	126,66	80	16	30	105	16	45	105	20	60
9	52,6	46,42	30	10	25	30	12	40	30	12	55	26	139,0	131,70	85	20	35	110	20	45	110	20	60
10	57,5	51,37	35	10	25	35	12	40	35	16	55	27	144,0	136,75	85	20	35	110	20	45	110	20	60
11	63,0	56,34	37	12	30	39	14	40	39	16	55	28	148,7	141,78	90	20	35	115	20	45	115	20	60
12	68,0	61,34	42	12	30	44	14	40	44	16	55	29	153,8	146,83	90	20	35	115	20	45	115	20	60
13	73,0	66,32	47	12	30	49	14	40	49	16	55	30	158,8	151,87	90	20	35	120	20	45	120	20	60
14	78,0	71,34	52	12	30	54	14	40	54	16	55	31	163,9	156,92	95	20	35	120	20	45	120	20	60
15	83,0	76,36	57	12	30	59	14	40	59	16	55	32	168,9	161,95	95	20	35	120	20	45	120	20	60
16	88,0	81,37	60	12	30	64	16	45	64	16	60	33	174,5	167,00	95	20	35	120	20	45	120	20	60
17	93,0	86,39	60	12	30	69	16	45	69	16	60	34	179,0	172,05	95	20	35	120	20	45	120	20	60
18	98,3	91,42	70	14	30	74	16	45	74	16	60	35	184,1	177,10	95	20	35	120	20	45	120	20	60
19	103,3	96,45	70	14	30	79	16	45	79	16	60	36	189,1	182,15	100	20	35	120	20	45	120	25	60
20	108,4	101,49	75	14	30	84	16	45	84	16	60	37	194,2	187,20	100	20	35	120	20	45	120	25	60
21	113,4	106,52	75	16	30	85	16	45	85	20	60	38	199,2	192,24	100	20	35	120	20	45	120	25	60
22	118,0	111,55	80	16	30	90	16	45	90	20	60	39	204,2	197,29	100	20	35	120	20	45	120	25	60
23	123,4	116,58	80	16	30	95	16	45	95	20	60	40	209,3	202,34	100	20	35	120	20	45	120	25	60
24	128,3	121,62	80	16	30	100	16	45	100	20	60												

Kettenräder Sprockets

Kettenräder mit einseitiger Nabe für Simplex-, Duplex- und Triplex-Rollenkette nach DIN 8187 - ISO/R 606
Sprockets for simplex, duplex and triplex chain according to DIN 8187 - ISO/R 606

12B

Kette chain	mm	Kettenräder sprockets	mm
Teilung Pitch	19,05	Radius Tooth radius r	19
Innere Breite Internal width	11,68	Breite radius width c	2
Rollen Roller \varnothing	12,07	Zahnbreite Tooth width h_1	11,1
		Zahnbreite Tooth width L	10,8
		Zahnbreite Tooth width h_2	30,3
		Zahnbreite Tooth width h_3	49,8
		Gesamthöhe Full height H	—

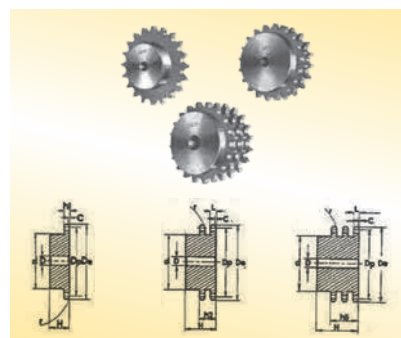

Material C 45 E - UNI EN 10083-1

3/4" x 7/16"

19,05 x 11,68 mm

Z	De	Dp	SIMPLEX			DUPLEX			TRIPLEX			Z	De	Dp	SIMPLEX			DUPLEX			TRIPLEX		
			d	D	H	d	D	H	d	D	H				d	D	H	d	D	H	d	D	H
8	57,6	49,78	31	12	30	31	12	45	31	16	65	25	160,0	152,00	90	20	40	120	20	50	120	20	70
9	62,0	55,70	37	12	30	37	12	45	37	16	65	26	165,9	158,04	95	20	40	120	20	50	120	20	70
10	69,0	61,64	42	12	30	42	12	45	42	16	65	27	172,3	164,09	95	20	40	120	20	50	120	20	70
11	75,0	67,61	46	14	35	47	16	50	47	20	70	28	178,0	170,13	95	20	40	120	20	50	120	20	70
12	81,5	73,60	52	14	35	53	16	50	53	20	70	29	184,1	176,19	95	20	40	120	20	50	120	20	70
13	87,5	79,59	58	14	35	59	16	50	59	20	70	30	190,5	182,25	95	20	40	120	20	50	120	20	70
14	93,6	85,61	64	14	35	65	16	50	65	20	70	31	196,3	188,31	100	20	40	130	20	50	130	25	70
15	99,8	91,63	70	14	35	71	16	50	71	20	70	32	203,3	194,35	100	20	40	130	20	50	130	25	70
16	105,5	97,65	75	16	35	77	20	50	77	20	70	33	209,3	200,40	100	20	40	130	20	50	130	25	70
17	111,5	103,67	80	16	35	83	20	50	83	20	70	34	214,6	206,46	100	20	40	130	20	50	130	25	70
18	118,0	109,71	80	16	35	89	20	50	89	20	70	35	221,0	212,52	100	20	40	130	20	50	130	25	70
19	124,2	115,75	80	16	35	95	20	50	95	20	70	36	226,8	218,58	100	20	40	130	25	50	130	25	70
20	129,7	121,78	80	16	35	100	20	50	100	20	70	37	232,9	224,64	100	20	40	130	25	50	130	25	70
21	136,0	127,82	90	20	40	100	20	50	100	20	70	38	239,0	230,69	100	20	40	130	25	50	130	25	70
22	141,8	133,86	90	20	40	100	20	50	100	20	70	39	245,1	236,75	100	20	40	130	25	50	130	25	70
23	149,0	139,90	90	20	40	110	20	50	110	20	70	40	251,3	242,81	100	20	40	130	25	50	130	25	70
24	153,9	145,94	90	20	40	110	20	50	110	20	70												

Lagerverfügbarkeit der Kettenräder von Z=41 bis Z=125 ist zu prüfen. Availability of sprockets from Z=41 to Z=125 can be checked on demand.

Kettenräder Sprockets

Kettenräder mit einseitiger Nabe für Simplex-, Duplex- und Triplex-Rollenkette nach DIN 8187 - ISO/R 606
Sprockets for simplex, duplex and triplex chain according to DIN 8187 - ISO/R 606

16B

Kette chain	mm	Kettenräder sprockets	mm
Teilung Pitch	25,4	Radius Tooth radius	r 26
Innere Breite Internal width	17,02	Breite radius width	c 2,5
Rollen Roller	∅ 15,88	Zahnbreite Tooth width	h ₁ 16,2
		Zahnbreite Tooth width	L 15,8
		Zahnbreite Tooth width	h ₂ 47,7
		Zahnbreite Tooth width	h ₃ 79,6
		Gesamthöhe Full height	H —

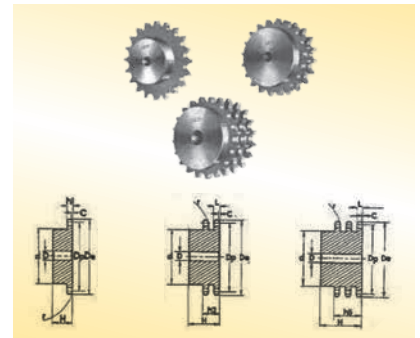

Material C 45 E - UNI EN 10083-1

* Typen mit eingeschweisster Nabe, Fe 50
Types with welded hub, Fe 50

1" x 17,02 mm

25,4 x 17,02 mm

Z	De	Dp	SIMPLEX			DUPLEX			TRIPLEX			Z	De	Dp	SIMPLEX			DUPLEX			TRIPLEX		
			d	D	H	d	D	H	d	D	H				d	D	H	d	D	H	d	D	H
8	77,0	66,37	42	16	35	42	16	65	42	20	95	25	213,5	202,66	110	20	50	*130	25	70	*130	30	100
9	85,0	74,27	50	16	35	50	16	65	50	20	95	26	221,6	210,72	120	20	50	*130	25	70	*130	30	100
10	93,0	82,19	55	16	35	56	16	65	56	20	95	27	229,6	218,79	120	20	50	*130	25	70	*130	30	100
11	99,5	90,14	61	16	40	64	20	70	64	25	100	28	237,7	226,85	120	20	50	*130	25	70	*130	30	100
12	109,0	98,14	69	16	40	72	20	70	72	25	100	29	245,8	234,92	120	20	50	*130	25	70	*130	30	100
13	117,0	106,12	78	16	40	80	20	70	80	25	100	30	254,0	243,00	120	20	50	*130	25	70	*130	30	100
14	125,0	114,15	84	16	40	88	20	70	88	25	100	31	262,0	251,08	*120	25	50	*140	25	70	*140	30	100
15	133,0	122,17	92	16	40	96	20	70	96	25	100	32	270,0	259,13	*120	25	50	*140	25	70	*140	30	100
16	141,0	130,20	100	20	45	104	20	70	104	30	100	33	278,5	267,21	*120	25	50	*140	25	70	*140	30	100
17	149,0	138,22	100	20	45	112	20	70	112	30	100	34	287,0	275,28	*120	25	50	*140	25	70	*140	30	100
18	157,0	146,28	100	20	45	120	20	70	120	30	100	35	296,2	283,36	*120	25	50	*140	25	70	*140	30	100
19	165,2	154,33	100	20	45	128	20	70	128	30	100	36	304,6	291,44	*120	25	50	*140	25	70	*140	30	100
20	173,2	162,38	100	20	45	130	20	70	130	30	100	37	312,6	299,51	*120	25	50	*140	25	70	*140	30	100
21	181,2	170,43	110	20	50	130	25	70	*130	30	100	38	320,7	307,59	*120	25	50	*140	25	70	*140	30	100
22	189,3	178,48	110	20	50	*130	25	70	*130	30	100	39	328,8	315,67	*120	25	50	*140	25	70	*140	30	100
23	197,5	186,53	110	20	50	*130	25	70	*130	30	100	40	336,9	323,73	*120	25	50	*140	25	70	*140	30	100
24	205,5	194,59	110	20	50	*130	25	70	*130	30	100												

Kettenräder Sprockets

Kettenräder mit einseitiger Nabe für Simplex-, Duplex- und Triplex-Rollenkette nach DIN 8187 - ISO/R 606
Sprockets for simplex, duplex and triplex chain according to DIN 8187 - ISO/R 606

20B

Kette chain	mm	Kettenräder sprockets	mm
Teilung Pitch	31,75	Radius Tooth radius	r 32
Innere Breite Internal width	19,56	Breite radius width	c 3,5
Rollen Roller \varnothing	19,05	Zahnbreite Tooth width	h_1 18,5
		Zahnbreite Tooth width	L 18,2
		Zahnbreite Tooth width	h_2 54,6
		Zahnbreite Tooth width	h_3 91
		Gesamthöhe Full height	H —

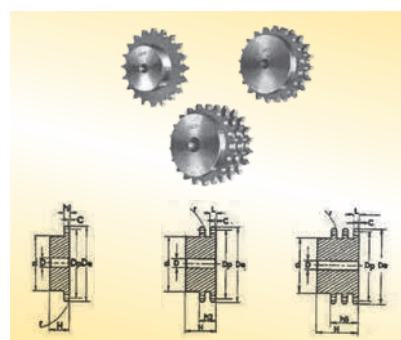

Material C 45 E - UNI EN 10083-1

* Typen mit eingeschweisster Nabe, Fe 50
Types with welded hub, Fe 50

1"1/4 x 3/4

31,75 x 19,56 mm

Z	De	Dp	SIMPLEX			DUPLEX			TRIPLEX			Z	De	Dp	SIMPLEX			DUPLEX			TRIPLEX		
			d	D	H	d	D	H	d	D	H				d	D	H	d	D	H	d	D	H
8	98,1	82,96	53	20	40	53	20	75	53	20	110	25	268,5	253,33	140	25	55	*140	25	80	*140	25	115
9	108,0	92,84	63	20	40	63	20	75	63	20	110	26	278,6	263,40	*150	25	55	*150	25	80	*150	25	115
10	117,9	102,74	70	20	40	70	20	75	70	20	110	27	288,6	273,48	*150	25	55	*150	25	80	*150	25	115
11	127,8	112,68	77	20	45	80	20	80	80	20	115	28	298,7	283,56	*150	25	55	*150	25	80	*150	25	115
12	137,8	122,68	88	20	45	90	20	80	90	20	115	29	308,8	293,65	*150	25	55	*150	25	80	*150	25	115
13	147,8	132,65	98	20	45	100	20	80	100	20	115	30	318,9	303,75	*150	25	55	*150	25	80	*150	25	115
14	157,8	142,68	108	20	45	110	20	80	110	20	115	31	329,0	313,85	*150	25	55	*150	25	80	*150	30	115
15	167,9	152,72	118	20	45	120	20	80	120	20	115	32	339,1	323,91	*150	25	55	*150	25	80	*150	30	115
16	177,9	162,75	120	25	50	120	25	80	120	25	115	33	349,2	334,01	*150	25	55	*150	25	80	*150	30	115
17	187,9	172,78	120	25	50	120	25	80	120	25	115	34	359,3	334,10	*150	25	55	*150	25	80	*150	30	115
18	198,0	182,85	120	25	50	*120	25	80	*120	25	115	35	369,4	354,20	*150	25	55	*150	25	80	*150	30	115
19	208,1	192,91	120	25	50	*120	25	80	*120	25	115	36	379,5	364,30	*150	25	55	*150	30	80	*150	30	115
20	218,1	202,98	120	25	50	*120	25	80	*120	25	115	37	389,5	374,39	*150	25	55	*150	30	80	*150	30	115
21	228,2	213,04	140	25	55	*140	25	80	*140	25	115	38	399,6	384,49	*150	25	55	*150	30	80	*150	30	115
22	238,3	223,11	140	25	55	*140	25	80	*140	25	115	39	409,7	394,59	*150	25	55	*150	30	80	*150	30	115
23	248,3	233,17	140	25	55	*140	25	80	*140	25	115	40	419,8	404,66	*150	25	55	*150	30	80	*150	30	115
24	258,4	243,23	140	25	55	*140	25	80	*140	25	115												

Lagerverfügbarkeit der Kettenräder von Z=41 bis Z=125 ist zu prüfen. Availability of sprockets from Z=41 to Z=125 can be checked on demand.

Kettenräder Sprockets

Kettenräder mit einseitiger Nabe für Simplex-, Duplex- und Triplex-Rollenkette nach DIN 8187 - ISO/R 606
Sprockets for simplex, duplex and triplex chain according to DIN 8187 - ISO/R 606

24B

Kette chain	mm	Kettenräder sprockets	mm
Teilung Pitch	38,1	Radius Tooth radius	r 38
Innere Breite Internal width	25,4	Breite radius width	c 4
Rollen Roller	∅ 25,4	Zahnbreite Tooth width	h ₁ 24,1
		Zahnbreite Tooth width	L 23,6
		Zahnbreite Tooth width	h ₂ 72
		Zahnbreite Tooth width	h ₃ 120,3
		Gesamthöhe Full height	H —

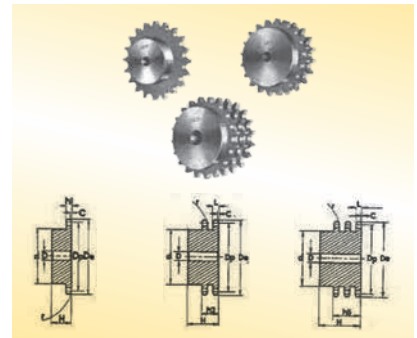

Material C 45 E - UNI EN 10083-1

* Typen mit eingeschweisster Nabe, Fe 50
Types with welded hub, Fe 50

1"1/2 x 1"

38,1 x 25,4 mm

Z	De	Dp	SIMPLEX			DUPLEX			TRIPLEX			Z	De	Dp	SIMPLEX			DUPLEX			TRIPLEX		
			d	D	H	d	D	H	d	D	H				d	D	H	d	D	H	d	D	H
8	115,0	99,55	58	20	45	58	25	95	58	25	140	25	319,0	304,00	*150	25	60	*160	25	100	*160	30	150
9	126,4	111,40	70	20	45	70	25	95	70	25	140	26	331,0	316,08	*160	30	60	*160	30	100	*160	30	150
10	138,0	123,29	80	20	45	80	25	95	80	25	140	27	343,2	328,19	*160	30	60	*160	30	100	*160	30	150
11	150,0	135,21	90	25	50	90	25	100	90	25	150	28	355,2	340,27	*160	30	60	*160	30	100	*160	30	150
12	162,0	147,22	102	25	50	102	25	100	102	25	150	29	367,3	352,38	*160	30	60	*160	30	100	*160	30	150
13	174,2	159,18	114	25	50	114	25	100	114	25	150	30	379,5	364,50	*160	30	60	*160	30	100	*160	30	150
14	186,2	171,22	128	25	50	128	25	100	128	25	150	31	391,6	376,62	*160	30	60	*170	30	100	*170	40	150
15	198,2	183,26	140	25	50	140	25	100	140	25	150	32	403,7	388,69	*160	30	60	*170	30	100	*170	40	150
16	210,3	195,30	*140	25	55	*140	25	100	*140	25	150	33	415,8	400,81	*160	30	60	*170	30	100	*170	40	150
17	222,3	207,34	*140	25	55	*150	25	100	*150	25	150	34	427,8	412,93	*160	30	60	*170	30	100	*170	40	150
18	234,3	219,42	*140	25	55	*160	25	100	*160	25	150	35	440,0	425,04	*160	30	60	*170	30	100	*170	40	150
19	246,5	231,49	*140	25	55	*160	25	100	*160	25	150	36	452,0	437,16	*160	30	60	*170	30	100	*170	40	150
20	258,6	243,57	*140	25	55	*160	25	100	*160	25	150	37	464,2	449,27	*160	30	60	*170	30	100	*170	40	150
21	270,6	255,65	*150	25	60	*160	25	100	*160	30	150	38	476,2	461,39	*160	30	60	*170	30	100	*170	40	150
22	282,7	267,73	*150	25	60	*160	25	100	*160	30	150	39	488,5	473,50	*160	30	60	*170	30	100	*170	40	150
23	294,8	279,80	*150	25	60	*160	25	100	*160	30	150	40	500,6	485,62	*160	30	60	*170	30	100	*170	40	150
24	306,8	291,88	*150	25	60	*160	25	100	*160	30	150												

Kettenräder Sprockets

Kettenräder mit einseitiger Nabe für Simplex-, Duplex- und Triplex-Rollenkette nach DIN 8187 - ISO/R 606
Sprockets for simplex, duplex and triplex chain according to DIN 8187 - ISO/R 606

28B

Kette chain	mm	Kettenräder sprockets	mm
Teilung Pitch	44,45	Radius Tooth radius	r 44
Innere Breite Internal width	30,99	Breite radius width	c 5
Rollen Roller \varnothing	27,94	Zahnbreite Tooth width	h_1 29,4
		Zahnbreite Tooth width	L 28,8
		Zahnbreite Tooth width	h_2 88,4
		Zahnbreite Tooth width	h_3 148
		Gesamthöhe Full height	H —

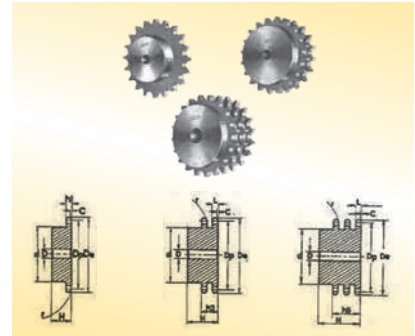

Material C 45 E - UNI EN 10083-1

* Typen mit eingeschweisster Nabe, Fe 50
Types with welded hub, Fe 50

1"3/4 x 1"1/4

44,45 x 30,99 mm

Z	De	Dp	SIMPLEX			DUPLEX			TRIPLEX			Z	De	Dp	SIMPLEX			DUPLEX			TRIPLEX		
			d	D	H	d	D	H	d	D	H				d	D	H	d	D	H	d	D	H
8	132,0	116,15	74	25	70	74	25	120	74	30	180	25	373,0	354,66	*170	30	75	*180	30	120	*180	40	180
9	148,4	129,96	88	25	70	88	25	120	88	30	180	26	387,0	368,77	*170	30	75	*180	30	120	*180	40	180
10	162,3	143,85	100	25	70	100	25	120	100	30	180	27	401,0	382,88	*170	30	75	*180	30	120	*180	40	180
11	176,3	157,77	112	25	70	112	25	120	112	30	180	28	416,0	397,00	*170	30	75	*180	30	120	*180	40	180
12	189,3	171,74	125	25	70	125	25	120	125	30	180	29	430,0	411,12	*170	30	75	*180	30	120	*180	40	180
13	204,2	185,75	*130	25	70	*130	25	120	*130	30	180	30	444,0	425,24	*170	30	75	*180	30	120	*180	40	180
14	218,2	199,76	*130	25	70	*130	25	120	*130	30	180	31	458,0	439,37	*180	30	75	*200	30	120	*200	40	180
15	232,3	213,79	*145	25	70	*145	30	120	*145	30	180	32	472,0	453,49	*180	30	75	*200	30	120	*200	40	180
16	246,3	227,84	*160	30	75	*160	30	120	*160	30	180	33	486,0	467,62	*180	30	75	*200	30	120	*200	40	180
17	260,0	241,90	*160	30	75	*160	30	120	*160	30	180	34	500,0	481,75	*180	30	75	*200	30	120	*200	40	180
18	274,0	255,98	*160	30	75	*160	30	120	*160	30	180	35	514,0	495,88	*180	30	75	*200	30	120	*200	40	180
19	289,0	270,06	*160	30	75	*180	30	120	*180	30	180	36	529,0	510,01	*180	30	75	*200	30	120	*200	40	180
20	303,0	284,15	*160	30	75	*180	30	120	*180	30	180	37	543,0	524,13	*180	30	75	*200	30	120	*200	40	180
21	317,0	298,24	*170	30	75	*180	30	120	*180	30	180	38	557,0	538,27	*180	30	75	*200	30	120	*200	40	180
22	331,0	312,34	*170	30	75	*180	30	120	*180	30	180	39	571,0	552,40	*180	30	75	*200	30	120	*200	40	180
23	345,0	326,44	*170	30	75	*180	30	120	*180	30	180	40	585,0	566,54	*180	30	75	*200	30	120	*200	40	180
24	359,0	340,55	*170	30	75	*180	30	120	*180	30	180												

Kettenräder Sprockets

Kettenräder mit einseitiger Nabe für Simplex-, Duplex- und Triplex-Rollenkette nach DIN 8187 - ISO/R 606
Sprockets for simplex, duplex and triplex chain according to DIN 8187 - ISO/R 606

32B

Kette chain	mm	Kettenräder sprockets	mm
Teilung Pitch	50,8	Radius Tooth radius	r 51
Innere Breite Internal width	30,99	Breite radius width	c 6
Rollen Roller	∅ 29,21	Zahnbreite Tooth width	h ₁ 29,4
		Zahnbreite Tooth width	L 28,8
		Zahnbreite Tooth width	h ₂ 87,4
		Zahnbreite Tooth width	h ₃ 146
		Gesamthöhe Full height	H —

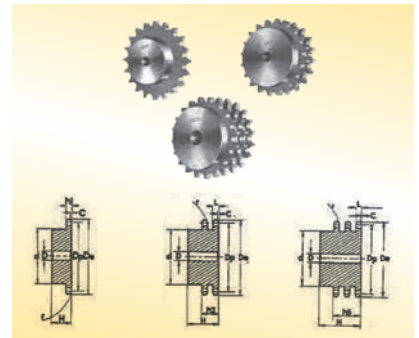

Material C 45 E - UNI EN 10083-1

* Typen mit eingeschweisster Nabe, Fe 50
Types with welded hub, Fe 50

2" x 1"1/4

50,8 x 30,99 mm

Z	De	Dp	SIMPLEX			DUPLEX			TRIPLEX			Z	De	Dp	SIMPLEX			DUPLEX			TRIPLEX		
			d	D	H	d	D	H	d	D	H				d	D	H	d	D	H	d	D	H
8	153,2	132,74	82	25	80	82	30	120	82	30	180	22	377,5	356,98	*180	30	90	*200	30	120	*200	40	180
9	169,0	148,54	88	25	80	88	30	120	88	30	180	23	393,6	373,08	*180	30	90	*200	30	120	*200	40	180
10	185,0	164,39	104	25	80	104	30	120	104	30	180	24	409,7	389,18	*180	30	90	*200	30	120	*200	40	180
11	200,8	180,31	120	30	80	120	30	120	120	30	180	25	425,8	405,33	*180	30	90	*200	30	120	*200	40	180
12	216,8	196,29	*133	30	80	*133	30	120	*133	30	180	26	441,9	421,44	*180	30	90	*200	30	120	*200	40	180
13	232,8	212,29	*145	30	80	*145	30	120	*145	30	180	27	458,1	437,59	*180	30	90	*200	30	120	*200	40	180
14	248,8	228,29	*160	30	80	*160	30	120	*160	30	180	28	474,2	453,69	*180	30	90	*200	30	120	*200	40	180
15	264,8	244,30	*160	30	80	*160	30	120	*160	30	180	29	492,0	469,85	*180	30	90						
16	280,9	260,40	*160	30	90	*160	30	120	*160	30	180	30	506,5	486,00	*180	30	90	*200	30	120	*200	40	180
17	296,9	276,46	*170	30	90	*180	30	120	*180	30	180	32	538,8	518,27	*180	30	90						
18	313,0	292,55	*170	30	90	*180	30	120	*180	30	180	35	589,5	566,71	*180	30	90						
19	329,1	308,66	*170	30	90	*200	30	120	*200	30	180	38	635,5	615,16	*180	30	90						
20	345,2	324,71	*180	30	90	*200	30	120	*200	30	180	40	670,3	647,47	*180	30	90						
21	361,3	340,82	*180	30	90	*200	30	120	*200	40	180												

Kettenradscheiben

Plate wheels

Kettenradscheiben für Simplex-, Duplex- und Triplex-Rollenkette nach DIN 8187 - ISO/R 606
 Plate wheels for simplex, duplex and triplex chain according to DIN 8187 - ISO/R 606

06B

Kette chain	mm	Kettenradscheiben plate wheels	mm
Teilung Pitch	9,525	Radius Tooth radius r	10
Innere Breite Internal width	5,72	Breite radius width c	1
Rollen Roller \varnothing	6,35	Zahnbreite Tooth width h_1	5,3
		Zahnbreite Tooth width L	5,2
		Zahnbreite Tooth width h_2	15,4
		Zahnbreite Tooth width h_3	25,6
		Gesamthöhe Full height H	—

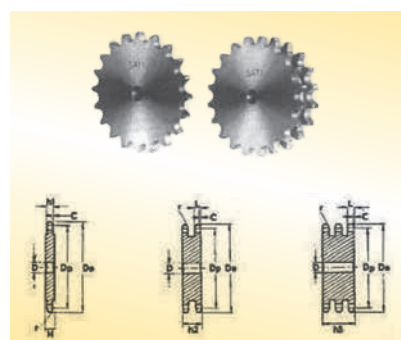

Seitlich plan gedrehte, wälzgefräste Zahnkränze
 Plate wheels turned on both sides and toothed by milling cutter

3/8" x 7/32"

9,525 x 5,72 mm

Z	De	Dp	SIMPLEX D	DUPLEX D	TRIPLEX D	Z	De	Dp	SIMPLEX D	DUPLEX D	TRIPLEX D
8	28,0	24,89	6	6	6	44	137,6	133,52	16	16	16
9	31,0	27,85	7	8	8	45	140,7	136,54	16	16	16
10	34,0	30,82	7	8	10	46	143,7	139,58	16	16	16
11	37,0	33,80	8	10	10	47	146,7	142,61	16	16	16
12	40,0	36,80	8	10	10	48	149,7	145,64	16	16	16
13	43,0	39,80	8	10	10	49	152,7	148,66	16	16	16
14	46,3	42,80	8	10	12	50	155,7	151,69	16	16	16
15	49,3	45,81	8	10	12	51	158,7	154,72	16	16	20
16	52,3	48,82	10	12	12	52	161,8	157,75	16	16	20
17	55,3	51,83	10	12	12	53	164,8	160,78	16	16	20
18	58,3	54,85	10	12	12	54	167,8	163,82	16	16	20
19	61,3	57,87	10	12	12	55	170,8	166,85	16	16	20
20	64,3	60,89	10	12	12	56	173,8	169,88	16	16	20
21	68,0	63,91	10	12	14	57	176,9	172,91	16	16	20
22	71,0	66,93	10	12	14	58	179,9	175,93	16	16	20
23	73,5	69,95	10	12	14	59	183,0	178,96	16	16	20
24	77,0	72,97	10	12	14	60	186,0	181,99	16	16	20
25	80,0	76,00	10	12	14	62	192,1	188,06	20	20	20
26	83,0	79,02	10	12	14	64	198,2	194,12	20	20	20
27	86,0	82,04	10	12	14	65	201,6	197,15	20	20	20
28	89,0	85,07	10	12	14	66	204,6	200,18	20	20	25
29	92,0	88,09	10	12	14	68	210,7	206,24	20	20	25
30	94,7	91,12	10	12	14	70	216,7	212,30	20	20	25
31	98,3	94,15	12	14	16	72	222,8	218,37	20	20	25
32	101,3	97,17	12	14	16	75	231,9	227,46	20	20	25
33	104,3	100,20	12	14	16	76	234,9	230,49	20	20	25
34	107,3	103,23	12	14	16	78	241,0	236,55	20	20	25
35	110,4	106,26	12	14	16	80	247,1	242,61	20	20	25
36	113,4	109,29	12	14	16	85	262,2	257,77	20	20	25
37	116,4	112,32	12	14	16	90	277,4	272,93	20	20	25
38	119,5	115,34	12	14	16	95	292,5	288,08	20	20	25
39	122,5	118,37	12	14	16	100	307,7	303,25	20	20	25
40	125,5	121,40	12	14	16	110	338,0	333,55	20	20	25
41	128,5	124,43	16	16	16	114	349,5	345,68	20	20	25
42	131,6	127,46	16	16	16	120	368,3	363,86	20	20	25
43	134,6	130,49	16	16	16	125	383,5	379,02	20	20	25

Kettenradscheiben Plate wheels

Kettenradscheiben für Simplex-, Duplex- und Triplex-Rollenkette nach DIN 8187 - ISO/R 606
Plate wheels for simplex, duplex and triplex chain according to DIN 8187 - ISO/R 606

08B

Kette chain	mm	Kettenradscheiben plate wheels	mm
Teilung Pitch	12,70	Radius Tooth radius	r 13
Innere Breite Internal width	7,75	Breite radius width	c 1,3
Rollen Roller	ø 8,51	Zahnbreite Tooth width	h ₁ 7,2
		Zahnbreite Tooth width	L 7
		Zahnbreite Tooth width	h ₂ 21
		Zahnbreite Tooth width	h ₃ 34,9
		Gesamthöhe Full height	H —

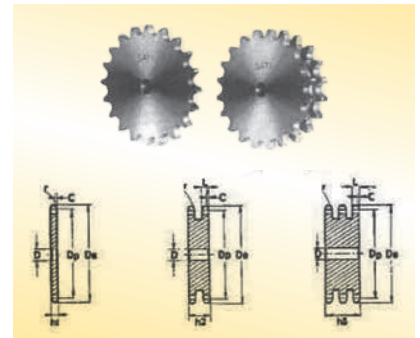

Seitlich plan gedrehte, wälzgefräste Zahnkränze
Plate wheels turned on both sides and toothed by milling cutter

1/2" x 5/16"

12,7 x 7,75 mm

Z	De	Dp	SIMPLEX D	DUPLEX D	TRIPLEX D	Z	De	Dp	SIMPLEX D	DUPLEX D	TRIPLEX D
8	37,2	33,18	8	10	10	44	183,8	178,03	20	20	25
9	41,0	37,13	8	10	10	45	188,0	182,07	20	20	25
10	45,2	41,10	8	10	10	46	192,1	186,10	20	20	25
11	48,7	45,07	10	10	12	47	196,2	190,14	20	20	25
12	53,0	49,07	10	10	12	48	200,3	194,18	20	20	25
13	57,4	53,06	10	10	12	49	204,3	198,22	20	20	25
14	61,8	57,07	10	10	12	50	208,3	202,26	20	20	25
15	65,5	61,09	10	10	12	51	212,1	206,30	20	25	25
16	69,5	65,10	10	12	16	52	216,1	210,34	20	25	25
17	73,6	69,11	10	12	16	53	220,2	214,37	20	25	25
18	77,8	73,14	10	12	16	54	224,1	218,43	20	25	25
19	81,7	77,16	10	12	16	55	228,1	222,46	20	25	25
20	85,8	81,19	10	12	16	56	232,2	226,50	20	25	25
21	89,7	85,22	12	16	16	57	236,4	230,54	20	25	25
22	93,8	89,24	12	16	16	58	240,5	234,58	20	25	25
23	98,2	93,27	12	16	16	59	244,5	238,62	20	25	25
24	101,8	97,29	12	16	16	60	248,6	242,66	20	25	25
25	105,8	101,33	12	16	16	62	256,9	250,75	25	25	25
26	110,0	105,36	16	16	16	64	265,1	258,82	25	25	25
27	114,0	109,40	16	16	16	65	269,0	262,86	25	25	25
28	118,0	113,42	16	16	16	66	273,0	266,90	25	25	25
29	122,0	117,46	16	16	16	68	281,0	274,99	25	25	25
30	126,1	121,50	16	16	16	70	289,0	283,07	25	25	25
31	130,2	125,54	16	16	20	72	297,2	291,16	25	25	25
32	134,3	129,56	16	16	20	75	309,2	303,27	25	25	25
33	138,4	133,60	16	16	20	76	313,3	307,33	25	25	25
34	142,6	137,64	16	16	20	78	321,4	315,40	25	25	25
35	146,7	141,68	16	16	20	80	329,4	323,48	25	25	25
36	151,0	145,72	16	20	20	85	349,0	343,69	25	25	25
37	154,6	149,76	16	20	20	90	369,9	363,90	25	25	25
38	158,6	153,80	16	20	20	95	390,1	384,11	25	25	25
39	162,7	157,83	16	20	20	100	410,3	404,31	25	25	25
40	166,8	161,87	16	20	20	110	450,7	444,74	25	25	25
41	171,4	165,91	20	20	25	114	466,9	460,90	25	25	25
42	175,4	169,95	20	20	25	120	491,2	485,16	25	25	25
43	179,7	173,99	20	20	25	125	511,3	505,37	25	25	25

Kettenradscheiben Plate wheels

Kettenradscheiben für Simplex-, Duplex- und Triplex-Rollenkette nach DIN 8187 - ISO/R 606
 Plate wheels for simplex, duplex and triplex chain according to DIN 8187 - ISO/R 606

10B

Kette chain	mm	Kettenradscheiben plate wheels	mm
Teilung Pitch	15,875	Radius Tooth radius r	16
Innere Breite Internal width	9,65	Breite radius width c	1,6
Rollen Roller \varnothing	10,16	Zahnbreite Tooth width h_1	9,1
		Zahnbreite Tooth width L	9
		Zahnbreite Tooth width h_2	25,5
		Zahnbreite Tooth width h_3	42,1
		Gesamthöhe Full height H	—

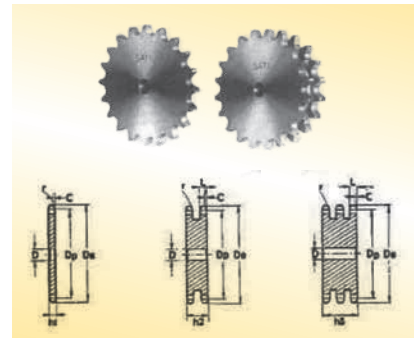

Seitlich plan gedrehte, wälzgefräste Zahnkränze
 Plate wheels turned on both sides and toothed by milling cutter

5/8" x 3/8"

15,875 x 9,65 mm

Z	De	Dp	SIMPLEX D	DUPLEX D	TRIPLEX D	Z	De	Dp	SIMPLEX D	DUPLEX D	TRIPLEX D
8	47,0	41,48	10	10	12	44	230,0	222,53	20	20	25
9	52,6	46,42	10	10	12	45	235,0	227,58	20	20	25
10	57,5	51,37	10	10	12	46	240,1	232,63	20	25	25
11	63,0	56,34	10	12	12	47	245,1	237,68	20	25	25
12	68,0	61,34	10	12	12	48	250,2	242,73	20	25	25
13	73,0	66,32	10	12	12	49	255,2	247,78	20	25	25
14	78,0	71,34	10	12	12	50	260,3	252,82	20	25	25
15	83,0	76,36	10	12	12	51	265,3	257,87	20	25	25
16	88,0	81,37	12	12	16	52	270,4	262,92	20	25	25
17	93,0	86,39	12	12	16	53	275,4	267,97	20	25	25
18	98,3	91,42	12	12	16	54	280,5	273,03	20	25	25
19	103,3	96,45	12	12	16	55	285,5	278,08	20	25	25
20	108,4	101,49	12	12	16	56	290,6	283,13	25	25	25
21	113,4	106,52	12	16	16	57	296,0	288,18	25	25	25
22	118,0	111,55	12	16	16	58	300,7	293,23	25	25	25
23	123,4	116,58	12	16	16	59	305,7	298,27	25	25	25
24	128,3	121,62	12	16	16	60	310,8	303,32	25	25	25
25	134,0	126,66	12	16	16	62	321,4	313,43	25	25	30
26	139,0	131,70	16	16	20	64	331,5	323,53	25	25	30
27	144,0	136,75	16	16	20	65	336,5	328,58	25	25	30
28	148,7	141,78	16	16	20	66	341,6	333,63	25	25	30
29	153,8	146,83	16	16	20	68	351,7	343,74	25	25	30
30	158,8	151,87	16	16	20	70	361,8	353,84	25	25	30
31	163,9	156,92	16	20	20	72	371,9	363,95	25	25	30
32	168,9	161,95	16	20	20	75	387,1	379,09	25	25	30
33	174,5	167,00	16	20	20	76	392,1	384,16	25	25	30
34	179,0	172,05	16	20	20	78	402,2	394,25	25	25	30
35	184,1	177,10	16	20	20	80	412,3	404,35	25	25	30
36	189,1	182,15	20	20	25	85	437,6	429,62	30	30	30
37	194,2	187,20	20	20	25	90	462,8	454,88	30	30	30
38	199,2	192,24	20	20	25	95	488,5	480,14	30	30	30
39	204,2	197,29	20	20	25	100	513,4	505,40	30	30	30
40	209,3	202,34	20	20	25	110	563,9	555,92	30	30	30
41	214,8	207,39	20	20	25	114	584,1	576,13	30	30	30
42	219,9	212,44	20	20	25	120	614,8	606,44	30	30	30
43	224,9	217,49	20	20	25	125	639,7	631,71	30	30	30

Kettenradscheiben Plate wheels

Kettenradscheiben für Simplex-, Duplex- und Triplex-Rollenkette nach DIN 8187 - ISO/R 606
Plate wheels for simplex, duplex and triplex chain according to DIN 8187 - ISO/R 606

12B

Kette chain	mm	Kettenradscheiben plate wheels	mm
Teilung Pitch	19,05	Radius Tooth radius	r 19
Innere Breite Internal width	11,68	Breite radius width	c 2
Rollen Roller	∅ 12,07	Zahnbreite Tooth width	h ₁ 11,1
		Zahnbreite Tooth width	L 10,8
		Zahnbreite Tooth width	h ₂ 30,3
		Zahnbreite Tooth width	h ₃ 49,8
		Gesamthöhe Full height	H —

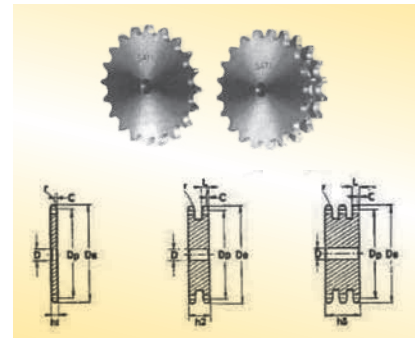

Seitlich plan gedrehte, wälzgefräste Zahnkränze
Plate wheels turned on both sides and toothed by milling cutter

3/4" x 7/16"

19,05 x 11,68 mm

Z	De	Dp	SIMPLEX D	DUPLEX D	TRIPLEX D	Z	De	Dp	SIMPLEX D	DUPLEX D	TRIPLEX D
8	57,6	49,78	12	12	12	44	276,5	267,03	25	25	25
9	62,0	55,70	12	12	12	45	282,5	273,10	25	25	25
10	69,0	61,64	12	12	12	46	287,9	279,16	25	25	25
11	75,0	67,61	14	14	16	47	294,0	285,21	25	25	25
12	81,5	73,60	14	14	16	48	300,1	291,27	25	25	25
13	87,5	79,59	14	14	16	49	306,2	297,33	25	25	25
14	93,6	85,61	14	14	16	50	312,3	303,39	25	25	25
15	99,8	91,63	14	14	16	51	318,4	309,45	25	25	25
16	105,5	97,65	14	16	16	52	324,5	315,50	25	25	25
17	111,5	103,67	14	16	16	53	330,5	321,56	25	25	25
18	118,0	109,71	14	16	16	54	336,6	327,64	25	25	25
19	124,2	115,75	14	16	16	55	342,7	333,70	25	25	25
20	129,7	121,78	14	16	16	56	348,7	339,75	25	25	30
21	136,0	127,82	16	16	20	57	355,4	345,81	25	25	30
22	141,8	133,86	16	16	20	58	361,5	351,87	25	25	30
23	149,0	139,90	16	16	20	59	367,5	357,93	25	25	30
24	153,9	145,94	16	16	20	60	373,0	363,99	25	25	30
25	160,0	152,00	16	16	20	62	385,1	376,12	25	30	30
26	165,9	158,04	16	20	20	64	397,2	388,24	25	30	30
27	172,3	164,09	16	20	20	65	403,2	394,29	25	30	30
28	178,0	170,13	16	20	20	66	409,2	400,35	30	30	30
29	184,1	176,19	16	20	20	68	421,4	412,49	30	30	30
30	190,5	182,25	16	20	20	70	433,6	424,60	30	30	30
31	196,3	188,31	20	20	25	72	447,0	436,74	30	30	30
32	203,3	194,35	20	20	25	75	463,9	454,91	30	30	30
33	209,3	200,40	20	20	25	76	469,9	460,99	30	30	30
34	214,6	206,46	20	20	25	78	482,1	473,10	30	30	30
35	221,0	212,52	20	20	25	80	494,2	485,22	30	30	30
36	226,8	218,58	20	25	25	85	524,5	515,55	30	30	30
37	232,9	224,64	20	25	25	90	554,8	545,86	30	30	30
38	239,0	230,69	20	25	25	95	585,1	576,17	30	30	30
39	245,1	236,75	20	25	25	100	615,4	606,47	30	30	30
40	251,3	242,81	20	25	25	110	676,1	667,11	30	30	30
41	257,3	248,87	25	25	25	114	700,6	691,36	30	30	30
42	264,5	254,93	25	25	25	120	736,7	727,74	30	30	30
43	270,5	260,98	25	25	25	125	767,0	758,05	30	30	30

Kettenradscheiben

Plate wheels

Kettenradscheiben für Simplex-, Duplex- und Triplex-Rollenkette nach DIN 8187 - ISO/R 606
 Plate wheels for simplex, duplex and triplex chain according to DIN 8187 - ISO/R 606

16B

Kette chain	mm	Ketteradscheiben plate wheels	mm
Teilung Pitch	25,4	Radius Tooth radius	r 26
Innere Breite Internal width	17,02	Breite radius width	c 2,5
Rollen Roller \varnothing	15,88	Zahnbreite Tooth width	h_1 16,2
		Zahnbreite Tooth width	L 15,8
		Zahnbreite Tooth width	h_2 47,7
		Zahnbreite Tooth width	h_3 79,6
		Gesamthöhe Full height	H —

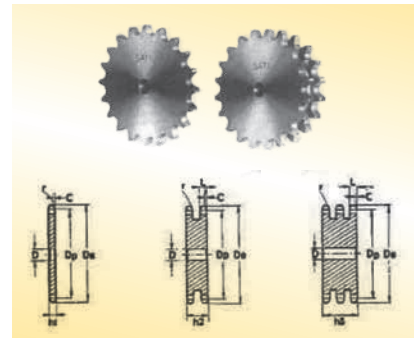

Seitlich plan gedrehte, wälzgefräste Zahnkränze
 Plate wheels turned on both sides and toothed by milling cutter

1" x 17,02 mm

25,4 x 17,02 mm

Z	De	Dp	SIMPLEX D	DUPLEX D	TRIPLEX D	Z	De	Dp	SIMPLEX D	DUPLEX D	TRIPLEX D
8	77,0	66,37	12	16	20	44	369,1	356,06	25	25	30
9	85,0	74,27	12	16	20	45	377,1	364,12	25	25	30
10	93,0	82,19	15	16	20	46	385,2	372,21	25	30	30
11	99,5	90,14	15	20	20	47	393,2	380,29	25		
12	109,0	98,14	15	20	20	48	401,3	388,36	25	30	30
13	117,0	106,12	15	20	20	49	409,3	396,44	25		
14	125,0	114,15	15	20	20	50	417,4	404,52	25	30	30
15	133,0	122,17	15	20	20	51	425,5	412,60	30	30	40
16	141,0	130,20	19	20	30	52	433,6	420,67	30	30	40
17	149,0	138,22	19	20	30	53	441,7	428,75	30		
18	157,0	146,28	19	20	30	54	448,3	436,85	30		
19	165,2	154,33	19	20	30	55	457,9	444,93	30	30	40
20	173,2	162,38	19	20	30	56	466,0	453,01	30	30	
21	181,2	170,43	20	25	30	57	474,0	461,07	30	30	40
22	189,3	178,48	20	25	30	58	482,1	469,16	30		
23	197,5	186,53	20	25	30	59	490,2	477,24	30		
24	205,5	194,59	20	25	30	60	498,3	485,32	30	30	40
25	213,5	202,66	20	25	30	62	514,5	501,50	30	30	
26	221,6	210,72	20	25	30	64	530,7	517,65	30		
27	229,6	218,79	20	25	30	65	538,8	525,73	30	30	40
28	237,7	226,85	20	25	30	66	546,8	533,80	30		
29	245,8	234,92	20	25	30	68	562,9	549,98	30	30	40
30	254,0	243,00	20	25	30	70	579,2	566,14	30	30	40
31	262,0	251,08	25	25	30	72	595,4	582,32	30	30	40
32	270,0	259,13	25	25	30	75	619,7	606,55	30	30	40
33	278,5	267,21	25	25	30	76	627,0	614,65	30	30	40
34	287,0	275,28	25	25	30	78	643,3	630,80	30		
35	296,2	283,36	25	25	30	80	660,0	646,96	30	30	40
36	304,6	291,44	25	25	30	85	699,9	687,40	30	30	40
37	312,6	299,51	25	25	30	90	740,3	727,81	30	30	40
38	320,7	307,59	25	25	30	95	781,1	768,22	30	30	40
39	328,8	315,67	25	25	30	100	821,1	808,63	30	30	40
40	336,9	323,73	25	25	30	110	902,0	889,48	30	30	40
41	345,0	331,82	25			114	934,3	921,81	30	40	40
42	353,0	339,90	25	25	30	120	982,8	970,33	30	40	40
43	361,1	347,98	25	25		125	1023,2	1010,73	30	40	40

Kettenradscheiben Plate wheels

Kettenradscheiben für Simplex-, Duplex- und Triplex-Rollenkette nach DIN 8187 - ISO/R 606
Plate wheels for simplex, duplex and triplex chain according to DIN 8187 - ISO/R 606

20B

Kette chain	mm	Kettenradscheiben plate wheels	mm
Teilung Pitch	31,75	Radius Tooth radius	r 32
Innere Breite Internal width	19,56	Breite radius width	c 3,5
Rollen Roller	∅ 19,05	Zahnbreite Tooth width	h ₁ 18,5
		Zahnbreite Tooth width	L 18,2
		Zahnbreite Tooth width	h ₂ 54,6
		Zahnbreite Tooth width	h ₃ 91
		Gesamthöhe Full height	H —

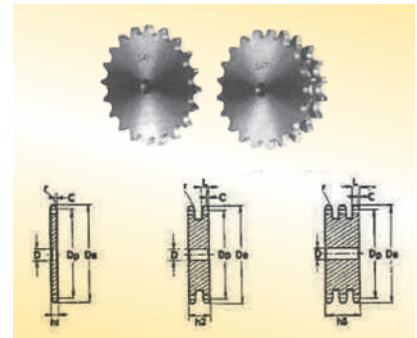

Seitlich plan gedrehte, wälzgefräste Zahnkränze
Plate wheels turned on both sides and toothed by milling cutter

1"1/4 x 3/4

31,75 x 19,56 mm

Z	De	Dp	SIMPLEX D	DUPLEX D	TRIPLEX D	Z	De	Dp	SIMPLEX D	DUPLEX D	TRIPLEX D
8	98,1	82,96	16	20	20	44	460,2	445,07	30		
9	108,0	92,84	16	20	20	45	470,3	455,17	30	30	40
10	117,9	102,74	16	20	20	46	480,4	465,26	30	30	40
11	127,8	112,68	20	20	20	47	490,5	475,36	30		
12	137,8	122,68	20	20	20	48	500,6	485,46	30	30	40
13	147,8	132,65	20	20	20	49	510,7	495,55	30		
14	157,8	142,68	20	20	20	50	520,8	505,65	30	30	40
15	167,9	152,72	20	20	20	51	530,9	515,75	30		
16	177,9	162,75	20	25	25	52	541,0	525,84	30	30	40
17	187,9	172,78	20	25	25	53	551,1	535,94	30		
18	198,0	182,85	20	25	25	54	561,2	546,07	30		
19	208,1	192,91	20	25	25	55	571,3	556,16	30	30	40
20	218,1	202,98	20	25	25	56	581,4	566,26	30		
21	228,2	213,04	25	25	25	57	591,5	576,36	30	30	40
22	238,3	223,11	25	25	25	58	601,6	586,45	30		
23	248,3	233,17	25	25	25	59	611,7	596,55	30		
24	258,4	243,23	25	25	25	60	621,8	606,65	30	30	40
25	268,5	253,33	25	25	25	62	642,0	626,87	30		
26	278,6	263,40	25	25	25	64	662,2	647,06	30		
27	288,6	273,48	25	25	25	65	672,3	657,16	30	30	40
28	298,7	283,56	25	25	25	66	682,4	667,26	30		
29	308,8	293,65	25	25	25	68	702,6	687,48	30		
30	318,9	303,75	25	25	25	70	722,8	707,67	30	30	40
31	329,0	313,85	25	25	30	72	743,1	727,90	30		
32	339,1	323,91	25	25	30	75	773,3	758,19	30		
33	349,2	334,01	25	25	30	76	783,5	768,32	30	30	40
34	359,3	334,10	25	25	30	80	823,9	808,72	30	30	40
35	369,4	354,20	25	25	30	85	874,4	859,25	30		
36	379,5	364,30	25	30	30	90	924,9	909,76	30		
37	389,5	374,39	25	30	30	95	975,2	960,28	30	30	40
38	399,6	384,49	25	30	30	100	1026,0	1010,79	30		
39	409,7	394,59	25	30	30	114	1167,4	1152,26	30	30	40
40	419,8	404,66	25	30	30						
41	429,9	414,78	30								
42	440,0	424,88	30	30	40						
43	450,1	434,97	30								

Kettenradscheiben

Plate wheels

Kettenradscheiben für Simplex-, Duplex- und Triplex-Rollenkette nach DIN 8187 - ISO/R 606
 Plate wheels for simplex, duplex and triplex chain according to DIN 8187 - ISO/R 606

24B

Kette chain	mm	Kettenradscheiben plate wheels	mm
Teilung Pitch	38,1	Radius Tooth radius	r 38
Innere Breite Internal width	25,4	Breite radius width	c 4
Rollen Roller \varnothing	25,4	Zahnbreite Tooth width	h_1 24,1
		Zahnbreite Tooth width	L 23,6
		Zahnbreite Tooth width	h_2 72
		Zahnbreite Tooth width	h_3 120,3
		Gesamthöhe Full height	H —

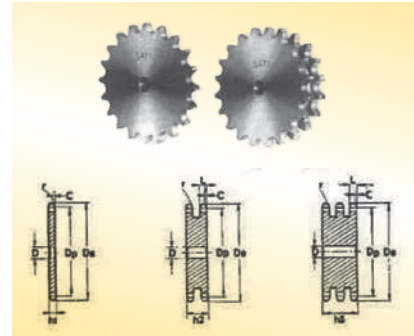

Seitlich plan gedrehte, wälzgefräste Zahnkränze
 Plate wheels turned on both sides and toothed by milling cutter

1"1/2 x 1"

38,1 x 25,4 mm

Z	De	Dp	SIMPLEX D	DUPLEX D	TRIPLEX D	Z	De	Dp	SIMPLEX D	DUPLEX D	TRIPLEX D
8	115,0	99,55	20	25	25	44	549,0	534,08	30		
9	126,4	111,40	20	25	25	45	561,2	546,20	30	40	40
10	138,0	123,29	20	25	25	46	573,3	558,32	30	40	40
11	150,0	135,21	20	25	25	47	585,4	570,43	30		
12	162,0	147,22	20	25	25	48	597,4	582,55	30	40	40
13	174,2	159,18	20	25	25	49	609,5	594,66	30		
14	186,2	171,22	20	25	25	50	621,7	606,78	30	40	40
15	198,2	183,26	20	25	25	51	633,8	618,89	30		
16	210,3	195,30	25	25	25	52	646,0	631,01	30		
17	222,3	207,34	25	25	25	53	658,0	643,13	30		
18	234,3	219,42	25	25	25	54	670,2	655,25	30		
19	246,5	231,49	25	25	25	55	682,3	667,40	30	40	40
20	258,6	243,57	25	25	25	56	694,4	679,50	30		
21	270,6	255,65	25	25	30	57	706,5	691,73	30	40	40
22	282,7	267,73	25	25	30	58	718,6	703,74	30		
23	294,8	279,80	25	25	30	59	730,7	715,86	30		
24	306,8	291,88	25	25	30	60	742,8	727,97	30	40	40
25	319,0	304,00	25	25	30	62	767,2	752,24	40		
26	331,0	316,08	30	30	30	64	791,3	776,48	40		
27	343,2	328,19	30	30	30	65	803,4	788,59	40	40	40
28	355,2	340,27	30	30	30	66	815,6	800,17	40		
29	367,3	352,38	30	30	30	68	839,8	824,98	40		
30	379,5	364,50	30	30	40	70	864,2	849,21	40		
31	391,6	376,62	30	40	40	72	888,4	873,48	40		
32	403,7	388,69	30	40	40	75	924,8	909,83	40		
33	415,8	400,81	30	40	40	76	936,9	921,98	40	40	40
34	427,8	412,93	30	40	40	80	985,4	970,44	40		
35	440,0	425,04	30	40	40	85	1046,0	1031,10	40		
36	452,0	437,16	30	40	40	95	1167,3	1152,33	40		
37	464,2	449,27	30	40	40						
38	476,2	461,39	30	40	40						
39	488,5	473,50	30	40	40						
40	500,6	485,62	30	40	40						
41	512,6	497,74	30								
42	524,7	509,85	30	40	40						
43	536,8	521,97	30								

Kettenradscheiben Plate wheels

Kettenradscheiben für Simplex-, Duplex- und Triplex-Rollenkette nach DIN 8187 - ISO/R 606
Plate wheels for simplex, duplex and triplex chain according to DIN 8187 - ISO/R 606

28B

Kette chain	mm	Kettenradscheiben plate wheels	mm
Teilung Pitch	44,45	Radius Tooth radius	r 44
Innere Breite Internal width	30,99	Breite radius width	c 5
Rollen Roller \varnothing	27,94	Zahnbreite Tooth width	h_1 29,4
		Zahnbreite Tooth width	L 28,8
		Zahnbreite Tooth width	h_2 88,4
		Zahnbreite Tooth width	h_3 148
		Gesamthöhe Full height	H —

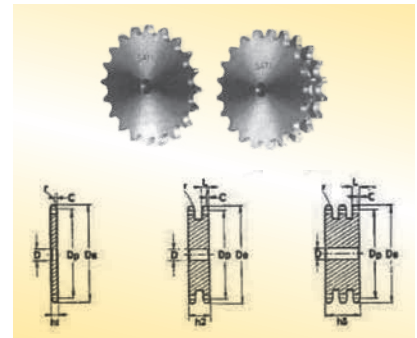

Seitlich plan gedrehte, wälzgefräste Zahnkränze
Plate wheels turned on both sides and toothed by milling cutter

1"3/4 x 1"1/4

44,45 x 30,99 mm

Z	De	Dp	SIMPLEX D	DUPLEX D	TRIPLEX D	Z	De	Dp	SIMPLEX D	DUPLEX D	TRIPLEX D
8	132,0	116,15	25	25	25	27	401,0	382,88	30	30	40
9	148,4	129,96	25	25	25	28	416,0	397,00	30	30	40
10	162,3	143,85	25	25	25	29	430,0	411,12	30	30	40
11	176,3	157,77	25	25	30	30	444,0	425,24	30	30	40
12	189,3	171,74	25	25	30	31	458,0	439,37	30	30	40
13	204,2	185,75	25	25	30	32	472,0	453,49	30	30	40
14	218,2	199,76	25	25	30	33	486,0	467,62	30	30	40
15	232,3	213,79	25	25	30	34	500,0	481,75	30	30	40
16	246,3	227,84	30	30	30	35	514,0	495,88	30	30	40
17	260,0	241,90	30	30	30	36	529,0	510,01	30	30	40
18	274,0	255,98	30	30	30	37	543,0	524,13	30	30	40
19	289,0	270,06	30	30	30	38	557,0	538,27	30	30	40
20	303,0	284,15	30	30	30	39	571,0	552,40	30	30	40
21	317,0	298,24	30	30	30	40	585,0	566,54	30	30	40
22	331,0	312,34	30	30	30	45	656,0	637,22	30	30	40
23	345,0	326,44	30	30	30	50	726,0	707,91	30	30	40
24	359,0	340,55	30	30	30	57	825,0	806,90	40	40	40
25	373,0	354,66	30	30	40	60	869,0	849,32	40	40	40
26	387,0	368,77	30	30	40	76	1095,0	1075,62	40	40	40

Kettenradscheiben

Plate wheels

Kettenradscheiben für Simplex-, Duplex- und Triplex-Rollenkette nach DIN 8187 - ISO/R 606
 Plate wheels for simplex, duplex and triplex chain according to DIN 8187 - ISO/R 606

32B

Kette chain	mm	Kettenradscheiben plate wheels	mm
Teilung Pitch	50,8	Radius Tooth radius r	51
Innere Breite Internal width	30,99	Breite radius width c	6
Rollen Roller \varnothing	29,21	Zahnbreite Tooth width h_1	29,4
		Zahnbreite Tooth width L	28,8
		Zahnbreite Tooth width h_2	87,4
		Zahnbreite Tooth width h_3	146
		Gesamthöhe Full height H	—

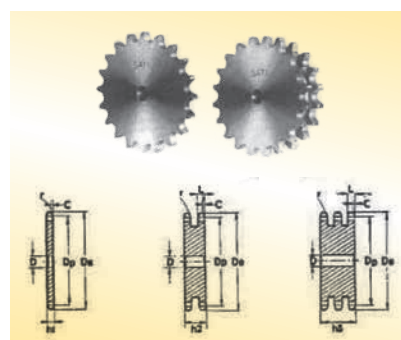

Seitlich plan gedrehte, wälzgefräste Zahnkränze
 Plate wheels turned on both sides and toothed by milling cutter

2" x 1"1/4

50,8 x 30,99 mm

Z	De	Dp	SIMPLEX D	DUPLEX D	TRIPLEX D	Z	De	Dp	SIMPLEX D	DUPLEX D	TRIPLEX D
8	153,2	132,74	25	25	25	24	409,7	389,18	30	30	40
9	169,0	148,54	25	25	25	25	425,8	405,33	30	30	40
10	185,0	164,39	25	25	25	26	441,9	421,44	30	30	40
11	200,8	180,31	30	30	30	27	458,1	437,59	30	30	40
12	216,8	196,29	30	30	30	28	474,2	453,69	30	30	40
13	232,8	212,29	30	30	30	29	492,0	469,85	30	30	40
14	248,8	228,29	30	30	30	30	506,5	486,00	30	30	40
15	264,8	244,30	30	30	30	32	538,8	518,27	30		
16	280,9	260,40	30	30	30	35	589,5	566,71	30	30	40
17	296,9	276,46	30	30	30	38	635,5	615,16	30	30	40
18	313,0	292,55	30	30	30	40	670,3	647,47	40	40	40
19	329,1	308,66	30	30	30	45	751,0	728,24	40	40	40
20	345,2	324,71	30	30	30	50	831,8	809,04	40	40	40
21	361,3	340,82	30	30	40	57	945,0	922,16	40	40	40
22	377,5	356,98	30	30	40	60	993,4	970,65	40	40	40
23	393,6	373,08	30	30	40	76	1252,0	1229,27	40	40	40

Kettenräder für Taperbuchsen Taper bored sprockets

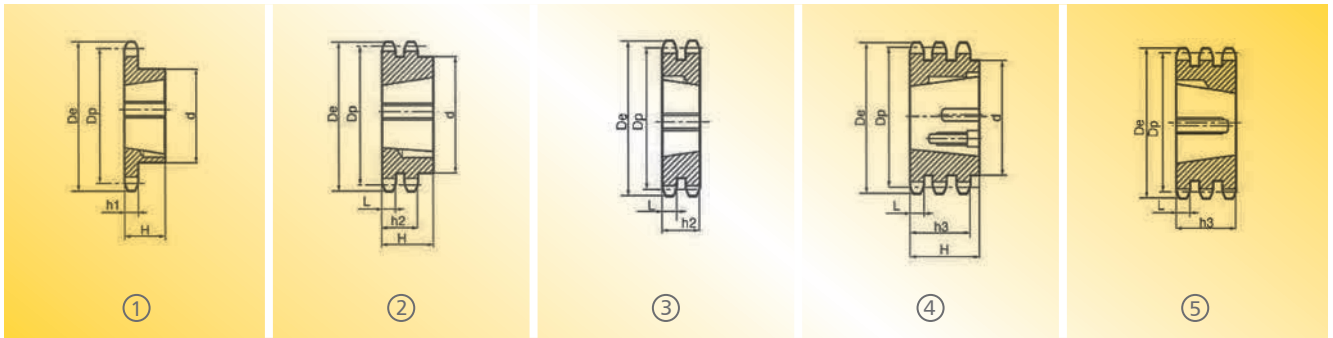

06B

Kette chain	mm	Kettenräder sprockets	mm
Teilung Pitch	9,525	Radius Tooth radius	r 10
Innere Breite Internal width	5,72	Breite radius width	c 1
Rollen Roller	∅ 6,35	Zahnbreite Tooth width	h ₁ 5,3
		Zahnbreite Tooth width	L 5,2
		Zahnbreite Tooth width	h ₂ 15,4
		Zahnbreite Tooth width	h ₃ 25,6

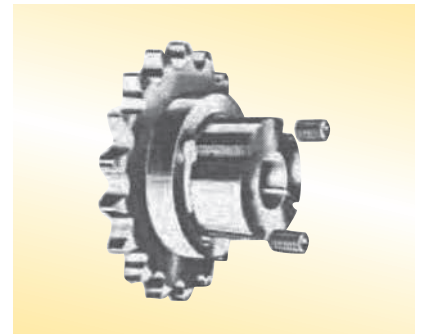

Material C 45 E - UNI EN 10083-1

3/8" x 7/32"

9,525 x 5,72 mm

Z	De	Dp	SIMPLEX				DUPLEX				TRIPLEX			
			d	H	für Buchse for Bush	Type	d	H	für Buchse for Bush	Type	d	H	für Buchse for Bush	Type
17	55,3	51,83	45	22	1008	1	41	22	1008	2	—	25,6	1008	5
18	58,3	54,85	45	22	1008	1	43	22	1008	2	—	25,6	1008	5
19	61,3	57,87	45	22	1008	1	46	22	1008	2	—	25,6	1008	5
20	64,3	60,89	46	22	1008	1	48	22	1008	2	—	25,6	1008	5
21	68,0	63,91	46	22	1008	1	49	22	1008	2	—	25,6	1008	5
22	71,0	66,93	50	22	1108	1	52	22	1108	2	—	25,6	1210	5
23	73,5	69,95	63	25	1210	1	59	25	1210	2	—	25,6	1210	5
24	77,0	72,97	63	25	1210	1	61	25	1210	2	—	25,6	1210	5
25	80,0	76,02	63	25	1210	1	64	25	1210	2	—	25,6	1210	5
26	83,0	79,02	63	25	1210	1	65	25	1210	2	—	25,6	1210	5
27	86,0	82,02	63	25	1210	1	70	25	1210	2	—	25,6	1210	5
28	89,0	85,07	63	25	1210	1	70	25	1210	2	—	25,6	1210	5
30	94,7	91,12	63	25	1210	1	75	25	1210	2	79	38	1615	4
38	119,5	115,35	70	25	1210	1	80	25	1610	2	90	38	1615	4
45	140,7	136,55	70	25	1210	1	80	25	1610	2				
57	176,9	172,91	70	25	1210	1	80	25	1610	2				
76	234,9	230,49	70	25	1210	1	80	25	1610	2				
95	292,5	288,08	80	25	1210	1	90	25	1610	2				
114	349,5	345,68	80	38	1215	1	95	38	1615	2				

Kettenräder für Taperbuchsen Taper bored sprockets

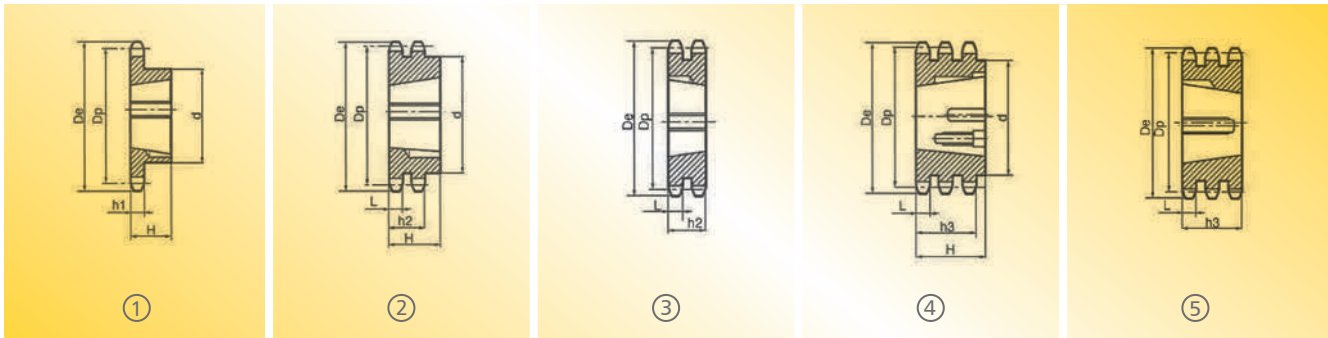

08B

Kette chain	mm	Kettenräder sprockets	mm
Teilung Pitch	12,70	Radius Tooth radius	r 13
Innere Breite Internal width	7,75	Breite radius width	c 1,3
Rollen Roller	∅ 8,51	Zahnbreite Tooth width	h ₁ 7,2
		Zahnbreite Tooth width	L 7
		Zahnbreite Tooth width	h ₂ 21
		Zahnbreite Tooth width	h ₃ 34,9

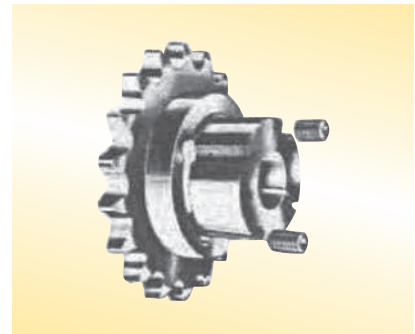

Stahl Steel C 45 E - UNI EN 10083-1

1/2" x 5/16"

12,7 x 7,75 mm

Z	De	Dp	SIMPLEX				DUPLEX				TRIPLEX			
			d	H	für Buchse for Bush	Typ Type	d	H	für Buchse for Bush	Typ Type	d	H	für Buchse for Bush	Typ Type
15	65,5	61,90	45	22	1008	1	46	22	1008	2	—	34,9	1008	5
16	69,5	65,10	50	22	1108	1	50	22	1108	2	—	—	—	—
17	73,6	69,11	60	25	1210	1	56	25	1210	2	—	34,9	1210	5
18	77,8	73,14	60	25	1210	1	60	25	1210	2	—	—	—	—
19	81,7	77,16	63	25	1210	1	62	25	1210	2	—	34,9	1210	5
20	85,8	81,19	71	25	1610	1	66	25	1610	2	—	—	—	—
21	89,7	85,22	71	25	1610	1	70	25	1610	2	—	34,9	1610	5
22	93,8	89,24	71	25	1610	1	76	25	1610	2	—	—	—	—
23	98,2	93,27	76	25	1610	1	79	25	1610	2	—	34,9	1610	5
24	101,8	97,29	76	25	1610	1	84	25	1610	2	—	—	—	—
25	105,8	101,33	76	25	1610	1	87	32	2012	2	—	34,9	2012	5
26	110,0	105,36	76	25	1610	1	87	32	2012	2	—	—	—	—
27	114,4	109,40	76	25	1610	1	87	32	2012	2	—	34,9	2012	5
28	118,0	113,42	90	32	2012	1	87	32	2012	2	—	—	—	—
30	126,1	121,50	90	32	2012	1	87	32	2012	2	—	34,9	2012	5
38	158,6	153,80	90	32	2012	1	100	32	2012	2	—	34,9	2012	5
45	188,0	182,07	100	32	2012	1	100	32	2012	2	—	—	—	—
57	236,4	230,54	100	32	2012	1	100	32	2012	2	—	—	—	—
76	313,3	307,33	100	32	2012	1	100	32	2012	2	—	—	—	—
95	390,1	384,11	100	32	2012	1	100	32	2012	2	—	—	—	—
114	466,9	460,90	110	45	2517	1	110	45	2517	2	—	—	—	—

Kettenräder für Taperbuchsen Taper bored sprockets

10B

Kette chain	mm	Kettenräder sprockets	mm
Teilung Pitch	15,875	Radius Tooth radius	r 16
Innere Breite Internal width	9,65	Breite radius width	c 1,6
Rollen Roller	∅ 10,16	Zahnbreite Tooth width	h ₁ 9,1
		Zahnbreite Tooth width	L 9
		Zahnbreite Tooth width	h ₂ 25,5
		Zahnbreite Tooth width	h ₃ 42,1

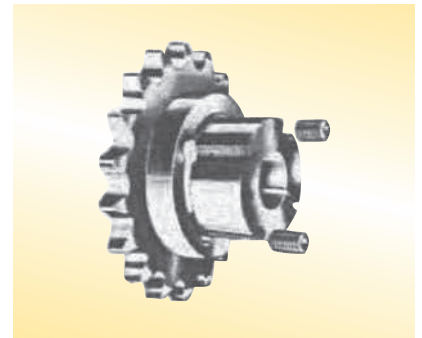

Stahl Steel C 45 E - UNI EN 10083-1

5/8" x 3/8"

15,875 x 9,65 mm

Z	De	Dp	SIMPLEX				DUPLEX				TRIPLEX			
			d	H	für Buchse for Bush	Typ Type	d	H	für Buchse for Bush	Typ Type	d	H	für Buchse for Bush	Typ Type
13	73,0	66,32	47	22	1008	1	—	25,5	1108	3				
14	78,0	71,34	52	22	1108	1								
15	83,0	76,36	60	25	1210	1	—	25,5	1210	3	—	42,1	1210	5
16	88,0	81,37	70	25	1610	1								
17	93,0	86,36	71	25	1610	1	—	25,5	1610	3	—	42,1	1210	5
18	98,3	91,42	75	25	1610	1								
19	103,3	96,45	75	25	1610	1	—	25,5	1610	3	—	42,1	1615	5
20	108,4	101,49	75	25	1610	1	—	25,5	1610	3				
21	113,4	106,52	76	25	1610	1	—	25,5	1610	3	—	42,1	1615	5
22	118,0	111,55	76	25	1610	1	—	25,5	1610	3				
23	123,4	116,58	76	25	1610	1	—	25,5	1610	3	—	42,1	2012	5
24	128,3	121,62	90	32	2012	1								
25	134,0	126,66	90	32	2012	1	90	32,0	2012	2	105	45,0	2517	4
26	139,0	131,70	90	32	2012	1								
27	144,0	136,75	90	32	2012	1	90	32,0	2012	2	110	45,0	2517	4
28	148,7	141,78	90	32	2012	1								
30	158,8	151,87	90	32	2012	1	90	32,0	2012	2	120	45,0	2517	4
38	199,2	192,24	100	32	2012	1	108	45,0	2517	2				
45	235,0	227,58	100	32	2012	1								
57	296,0	288,18	100	32	2012	1								
76	392,1	384,16	100	32	2012	1								
95	488,5	480,14	110	45	2517	1								
114	584,1	576,13	110	45	2517	1								

Kettenräder für Taperbuchsen Taper bored sprockets

12B

Kette chain	mm	Kettenräder sprockets	mm
Teilung Pitch	19,05	Radius Tooth radius r	19
Innere Breite Internal width	11,68	Breite radius width c	2
Rollen Roller \varnothing	12,07	Zahnbreite Tooth width h_1	11,1
		Zahnbreite Tooth width L	10,8
		Zahnbreite Tooth width h_2	30,3
		Zahnbreite Tooth width h_3	49,8



Stahl Steel C 45 E - UNI EN 10083-1

3/4" x 7/16"

19,05 x 11,68 mm

Z	De	Dp	SIMPLEX				DUPLEX				TRIPLEX				
			d	H	für Buchse for Bush	Typ Type	d	H	für Buchse for Bush	Typ Type	d	H	für Buchse for Bush	Typ Type	
13	87,5	79,59	60	25	1210	1									
14	93,6	85,61	70	25	1610	1									
15	99,8	91,63	70	25	1610	1	—	30,3	1610	3	—	49,8	1615	5	
16	105,5	97,65	75	25	1610	1	—	30,3	1610	3	—	49,8	2012	5	
17	111,5	103,67	76	25	1610	1	—	30,3	1610	3	—	49,8	2012	5	
18	118,0	109,71	90	32	2012	1	90	32	2012	2	—	49,8	2012	5	
19	124,2	115,75	90	32	2012	1	90	32	2012	2	—	49,8	2012	5	
20	129,7	121,78	90	32	2012	1	108	45	2517	2					
21	136,0	127,82	102	45	2517	1	108	45	2517	2	—	49,8	2517	5	
22	141,8	133,86	102	45	2517	1	108	45	2517	2					
23	149,0	139,90	108	45	2517	1	108	45	2517	2	—	49,8	2517	5	
24	153,9	145,94	108	45	2517	1	108	45	2517	2					
25	160,0	152,00	108	45	2517	1	108	45	2517	2	—	49,8	2517	5	
26	165,9	158,04	108	45	2517	1	108	45	2517	2					
27	172,3	164,00	108	45	2517	1	108	45	2517	2	140	51	3020	4	
28	178,0	170,13	108	45	2517	1	108	45	2517	2					
30	190,5	182,25	108	45	2517	1	108	45	2517	2	140	51	3020	4	
38	239,0	230,69	108	45	2517	1	140	51	3020	2	140	51	3020	4	
45	282,5	273,10	108	45	2517	1	140	51	3020	2	140	51	3020	4	
57	355,4	345,81	108	45	2517	1	140	51	3020	2	140	51	3020	4	
76	469,9	460,99	108	45	2517	1	140	51	3020	2	140	51	3020	4	
95	585,1	576,17	108	45	2517	1	140	51	3020	2					
114	700,6	691,36	108	64	2525	1									

Kettenräder für Taperbuchsen Taper bored sprockets

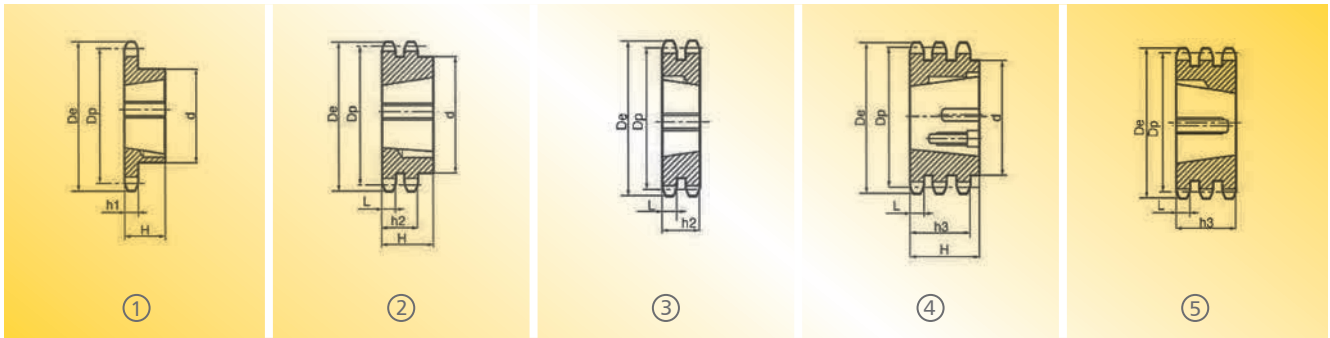

16B

Kette chain	mm	Kettenräder sprockets	mm
Teilung Pitch	25,4	Radius Tooth radius	r 26
Innere Breite Internal width	17,02	Breite radius width	c 2,5
Rollen Roller	∅ 15,88	Zahnbreite Tooth width	h ₁ 16,2
		Zahnbreite Tooth width	L 15,8
		Zahnbreite Tooth width	h ₂ 47,7
		Zahnbreite Tooth width	h ₃ 79,6



Stahl Steel C 45 E - UNI EN 10083-1

1" x 17,02 mm

25,4 x 17,02 mm

Z	De	Dp	SIMPLEX				DUPLEX				TRIPLEX			
			d	H	für Buchse for Bush	Typ Type	d	H	für Buchse for Bush	Typ Type	d	H	für Buchse for Bush	Typ Type
13	117,0	106,12	73	25	1610	1	—	47,7	2012	3				
14	125,0	114,15	76	25	1610	1								
15	133,0	122,17	76	25	1610	1	—	47,7	2012	3				
16	141,0	130,20	90	32	2012	1								
17	149,0	138,22	90	32	2012	1	—	47,7	2517	3	—	79,6	2517	5
18	157,0	146,28	108	45	2517	1								
19	165,2	154,33	108	45	2517	1	—	47,7	2517	3	—	79,6	3020	5
20	173,2	162,38	108	45	2517	1								
21	181,2	170,43	110	45	2517	1	140	51	3020	2	—	79,6	3030	5
22	189,3	178,48	110	45	2517	1								
23	197,5	186,53	110	45	2517	1	140	51	3020	2	—	79,6	3525	5
24	205,5	194,59	110	45	2517	1								
25	213,5	202,66	110	45	2517	1	140	51	3020	2	—	79,6	3525	5
26	221,6	210,72	110	45	2517	1								
27	229,6	218,79	110	45	2517	1	140	51	3020	2	—	79,6	3525	5
28	237,7	226,85	110	45	2517	1								
30	254,0	243,00	140	51	3020	1	140	51	3020	2	—	79,6	3525	5
38	320,7	307,59	140	51	3020	1	140	51	3020	2	—	79,6	3525	5
45	377,1	364,13	140	51	3020	1	140	51	3020	2	216	79,6	4030	5
57	474,0	461,07	140	51	3020	1	175	65	3525	2	216	79,6	4030	5
76	627,0	614,65	140	51	3020	1	175	65	3525	2	216	79,6	4030	5
95	781,1	768,22	140	51	3020	1	215	65	3525	2	240	79,6	4030	5
114	934,3	921,81	140	76	3030	1	215	102	4040	2				

Kettenräder für Taperbuchsen

Taper bored sprockets

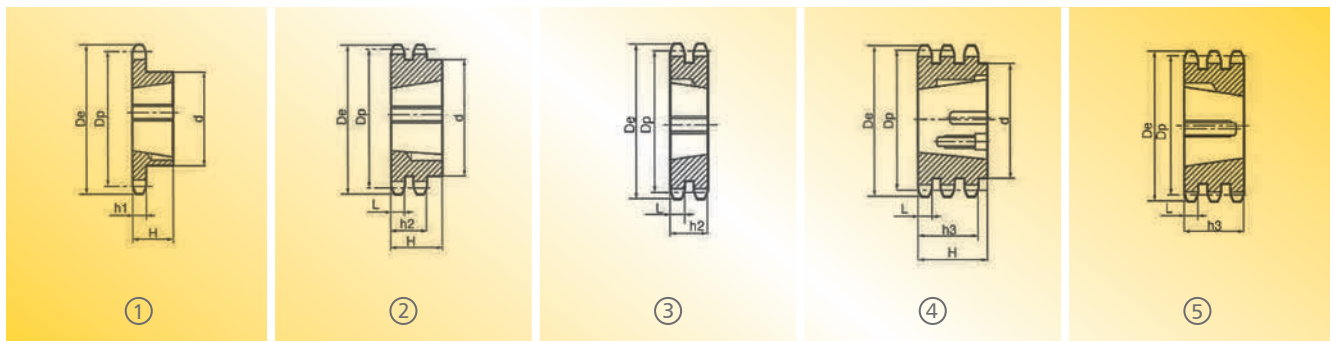

20B

Kette chain	mm	Kettenräder sprockets	mm
Teilung Pitch	31,75	Radius Tooth radius	r 32
Innere Breite Internal width	19,56	Breite radius width	c 3,5
Rollen Roller	∅ 19,05	Zahnbreite Tooth width	h ₁ 18,5
		Zahnbreite Tooth width	L 18,2
		Zahnbreite Tooth width	h ₂ 54,6
		Zahnbreite Tooth width	h ₃ 91



Stahl Steel C 45 E - UNI EN 10083-1

1" 1/4 x 3/4"

31,75 x 19,56 mm

z	De	Dp	SIMPLEX			
			d	H	für Buchse for Bush	Typ Type
13	147,8	132,65	90	32	2012	1
14	157,8	142,68	90	32	2012	1
15	167,9	152,72	108	45	2517	1
16	177,9	162,75	108	45	2517	1
17	187,9	172,78	108	45	2517	1
18	198,0	182,85	108	45	2517	1
19	208,1	192,91	108	45	2517	1
20	218,1	202,98	108	45	2517	1
21	228,2	213,04	108	45	2517	1
22	238,3	223,11	108	45	2517	1
23	248,3	233,17	108	45	2517	1
24	258,4	243,23	108	45	2517	1
25	268,5	253,33	108	45	2517	1
27	288,6	273,40	150	51	3020	1
30	318,9	303,75	150	51	3020	1
38	399,6	384,49	160	51	3020	1
45	470,3	455,17	160	51	3020	1
57	591,5	576,36	160	51	3020	1
76	783,5	768,32	160	51	3020	1

Taperbuchsen Taper bushes

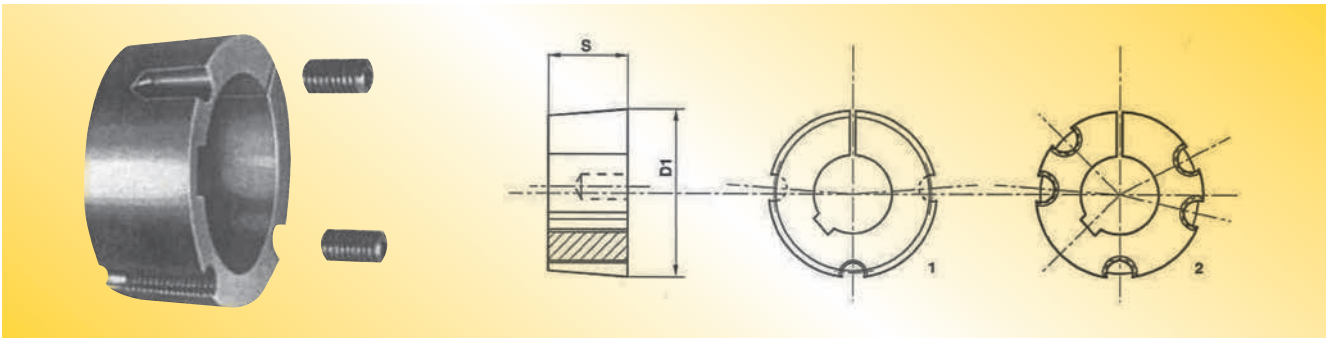

Grauguss Cast iron - EN-GJL-250 UNI EN 1561

Standard Lagerbohrung metrische Reihe Standard Stock bores metric series

für Buchse for Bush	Bohrungen Bore (ISO E 8)																Schraube Screw	Anzugs- moment Schrauben Screw tightening torque	D ₁	Typ Type	S	Gewicht weight				
	mm																						inch	Nm	mm	mm
1008	9	10	11	12	14	15	16	18	19	20	22	24*	25*					1/4 x 1/2	5,6	35,0	1	22,3	0,16			
1108	9	10	11	12	14	15	16	18	19	20	22	24	25	28*				1/4 x 1/2	5,6	38,0	1	22,3	0,16			
1210	11	12	14	15	16	18	19	20	22	24	25	28	30	32				3/8 x 5/8	19,6	47,5	1	25,4	0,32			
1215	14	19	20	24	25	28												3/8 x 5/8	19,6	47,5	1	38,1	0,50			
1610	14	15	16	18	19	20	22	24	25	28	30	32	35	38	40	42*		3/8 x 5/8	19,6	57,0	1	25,4	0,41			
1615	14	16	18	19	20	22	24	25	28	30	32	35	38	40	42*			3/8 x 5/8	19,6	57,0	1	38,1	0,60			
2012	14	16	18	19	20	22	24	25	28	30	32	35	38	40	42	45	48	50	7/16 x 7/8	30,4	70,0	1	31,8	0,75		
2517	16	18	19	20	22	24	25	28	30	32	35	38	40	42	45	48	50	55	60	65*	1/2 x 1	48	85,5	1	44,5	1,06
3020	25	28	30	32	35	38	40	42	45	48	50	55	60	65	70	75			5/8 x 1 1/4	90	108,0	1	50,8	2,50		
3030	35	38	40	42	45	48	50	55	60	65	70	75						5/8 x 1 1/4	90	108,0	1	76,2	3,75			
3525	35	38	40	42	45	48	50	55	60	65	70	75	80	85	90			1/2 x 1 1/2	112	127,0	2	64,9	4,20			
3535	35	38	40	42	45	48	50	55	60	65	70	75	80	85	90			1/2 x 1 1/2	112	127,0	2	88,9	5,13			
4030	40	42	45	48	50	55	60	65	70	75	80	85	90	100				5/8 x 1 1/4	169	146,0	2	76,2	6,75			
4040	40	42	45	48	50	55	60	65	70	75	80	85	90	95	100			5/8 x 1 3/4	169	146,0	2	101,6	7,68			
4545	55	60	65	70	75	80	85	90	95	100								3/4 x 2	192	162,0	2	115,0	10,56			
5040	70	75	80	85	90	95	100	105	110	115	120	125						7/8 x 2 1/4	271	177,6	2	101,6	14,20			
5050	70	75	80	85	90	95	100	105	110	115	120	125						7/8 x 2 1/4	271	177,6	2	127,0	15,17			

Abmessungen der Keilnuten (UNI 6604 DIN 6885) mit Standardbohrung, metrische Reihe Dimensions of keyways (UNI 6604 DIN 6885) with standard bore, metric series

D	b	Js9	t		Abmessungen der Keilnuten Dimensions of keyways		
					D*	b	t
Over 10 to 12	4	± 0,015	D + 1,8		24*	8	D + 1,3
Over 12 to 17	5		D + 2,3				
Over 17 to 22	6		D + 2,8				
Over 22 to 30	8	± 0,018	D + 3,3				
Over 30 to 38	10		D + 3,3				
Over 38 to 44	12		D + 3,3				
Over 44 to 50	14	± 0,021	D + 3,8				
Over 50 to 58	16		D + 4,3				
Over 58 to 65	18		D + 4,4				
Over 65 to 75	20	± 0,026	D + 4,9				
Over 75 to 85	22		D + 5,4				
Over 85 to 95	25		D + 5,4				
Over 95 to 110	28	± 0,031	D + 6,4				
Over 110 to 130	32		D + 7,4				

Führungsschienen, Kettenführungen und Riemenführungen *Guide rails, chain guides and belt guides*

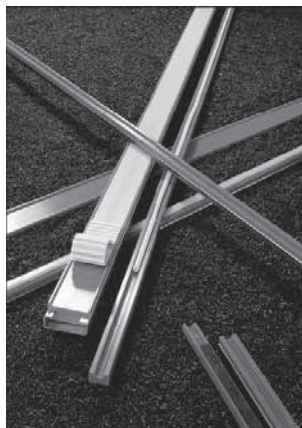

Führungsschienen *guide rails*

Führungsschienen bestehen durch ihre hervorragenden Eigenschaften wie Verschleißfestigkeit, Schlagfestigkeit und Säurebeständigkeit. PTS Strongbelt verfügt über eine große Lieferfähigkeit an verschiedensten Führungsschienen. Darüber hinaus besteht die Möglichkeit, technische Kunststoffe nach Kundenwunsch zu liefern.

Guide rails feature excellent properties including wear resistance, impact strength and acid resistance. PTS Strongbelt has a huge selection of guide rails in stock. Furthermore we can supply you with other technical plastics according to your requirements.

Kettenführungen *chain guides*

Die Kettenführungen werden der DIN 8187 folgend hergestellt in A4 grün und standardmäßig in einer Länge von 2000 mm.

The chain guides are manufactured according to DIN 8187 in A4 green and with a standard length of 2000 mm.

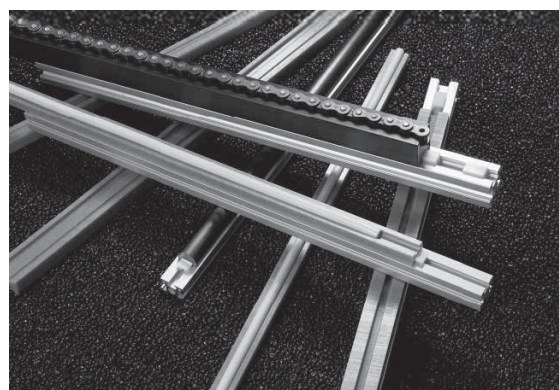
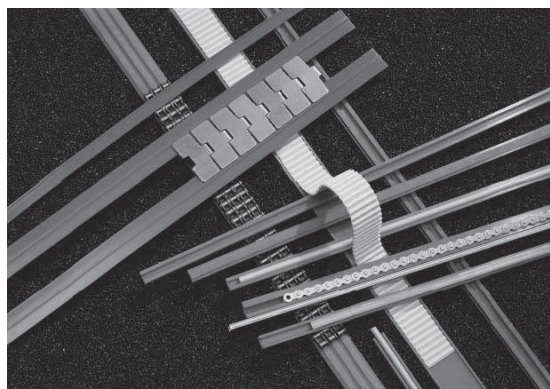

Riemenführungen *belt guides*

Die Riemenführungen werden standardmäßig in A4 grün / schwarz in einer Länge von 2000 mm produziert. Sie sind geeignet für Flachriemen, Keilriemen, Rundriemen oder auch Zahnriemen.

The belt guides are produced as standard in A4 green / black and with a length of 2000 mm. They are suitable for flat belts, v-belts, round belts or even timing belts.

Tapernaben Taper hubs



Anschraubnaben – Bolt on hubs

Bezeichnung Part No.	Material	Taper- Buchse Taper bush	DA (mm)	DT (mm)	D + 0/- 0,1 (mm)	DK (mm)	B (mm)	b (mm)	Z (mm)	BM (mm)	d (mm)	Gewicht o. Buchse Weight without bush (≈ kg)	€ Stück ohne Buchse each without bush
SM 12	GG	1210	180	135	90	75	25	6,5	2,5	11,5	6 x 7,5	1,5	auf Anfrage on request
SM 16	GG	1615	200	150	110	85	38	7,5	2,5	12,5	6 x 7,5	3,0	
SM 20	GG	2012	270	190	140	110	32	8,5	2,5	13,5	6 x 9,5		
SM 25	GG	2517	340	240	170	125	45	9,5	2,5	14,5	8 x 11,5	7,6	
SM 30-1	GG	3020	430	300	220	160	51	13,5	2,5	18,5	8 x 13,5	16,6	
SM 30-2	GG	3020	485	340	250	160	51	13,5	2,5	18,5	8 x 13,5	20,5	

Einschweißnaben Type WM – Weld on hubs type WM

Bezeichnung Part No.	Material	Taper- Buchse Taper bush	DA (mm)	D + 0/- 0,05 (mm)	DK (mm)	B + 0,5/- 0,05 (mm)	b1 (mm)	b2 (mm)	Gewicht o. Buchse Weight without bush (≈ kg)	€ Stück ohne Buchse each without bush
WM 1210	St	1210	70	60	58	25	9	10	0,3	auf Anfrage on request
WM 1615	St	1615	83	70	68	38	16	11	0,6	
WM 2012	St	2012	95	90	88	32	12	12	0,7	
WM 2517	St	2517	127	110	108	44	19	13	1,8	
WM 3030	St	3030	152	130	125	76	25	19	3,5	
WM 3535	St	3535	184	155	151	89	32	25	10,0	
WM 4040	St	4040	225	195	187	102	32	32	13,2	
WM 4545	St	4545	254	220	213	115	38	38	20,1	
WM 5050	St	5050	276	242	228	127	38	38	25,4	

Einschweißnaben Type WH – Weld on hubs type WH

Bezeichnung Part No.	Material	Taper- Buchse Taper bush	DA (mm)	D + 0/- 0,05 (mm)	DK (mm)	B + 0,5/- 0,05 (mm)	b1 (mm)	b2 (mm)	Gewicht o. Buchse Weight without bush (≈ kg)	€ Stück ohne Buchse each without bush
WH 1210	St	1210	70	65	64,5	25	9	10	0,3	auf Anfrage on request
WH 1610	St	1610	80	75	74,5	25	9	10		
WH 2012	St	2012	95	90	89,5	32	12	12		
WH 2517	St	2517	115	110	109,5	44	19	15		
WH 3020	St	3020	145	140	139,5	50	19	15	2,7	
WH 3525	St	3525	190	180	179,5	65	25	25		
WH 3535	St	3535	190	180	179,5	89	32	25	10,0	
WH 4040	St	4040	200	190	189,5	101	32	30		
WH 4545	St	4545	210	200	199,5	115	40	30		
WH 5050	St	5050	230	220	219,5	127	40	35		

Taperbuchse Taper bush	1210	1610	1615	2012	2517	3020	3030	3525	3535	4040	4545	5050
Bohrung d2 (mm) von ... bis ... Bore d2 (mm) from ... to ...	11-32	14-42	14-42	14-50	16-60	25-75	35-75	35-90	35-90	40-100	44-110	70-125
€/Stück each	auf Anfrage / on request											

Bohrungsdurchmesser d2 siehe Seite 3-4.
Bore diameters d2 see page 3-4.

Weitere Abmessungen auf Anfrage.
Further sizes on request.

GG = Grauguss
GG = Cast iron

St = Stahl
St = Steel

Fertigungstechnische Änderungen vorbehalten.
We reserve the right to make technical changes.

Zwischenhülsen Adapters

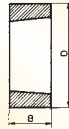

98

Bezeichnung Part No.	Material	Taper- Buchse Taper bush	D (mm)	B (mm)	Nut- querschnitt Keyway dimensions b x h (mm)	Minimaler Nabendurchmesser der Scheibe Minimum hub diameter			Gewicht ohne Buchse Weight without bush (≈ kg)	€ Stück ohne Buchse each without bush
						Material				
						GG	GGG	St		
1008 AM 1008 BM	St St	1008 1008	45 45	22 22	5 x 2,5	71 75	62 67	56 60	0,1 0,1	auf Anfrage on request
1210 AM 1210 BM	St St	1210 1210	60 60	25 25	6 x 3	86 92	79 86	73 83	0,2 0,2	
1610 AM 1610 BM	St St	1610 1610	70 70	25 25	10 x 4	95 102	89 95	83 89	0,3 0,3	
1615 AM 1615 BM	St St	1615 1615	70 70	38 38	10 x 4	95 102	89 95	83 89	0,4 0,4	
2517 AM 2517 BM	St St	2517 2517	105 105	45 45	16 x 4	143 149	133 140	121 127	1,0 1,0	
3030 AM 3030 BM	St St	3030 3030	130 130	76 76	20 x 5	178 187	165 175	156 159	2,5 2,5	
3535 AM 3535 BM	St St	3535 3535	160 160	89 89	22 x 5	222 232	203 213	191 200	5,2 5,2	
4040 AM 4040 BM	St St	4040 4040	185 185	102 102	24 x 5	273 283	248 257	229 238	8,0 8,0	

St = Stahl Steel GG = Grauguss Cast iron GGG = Globularer Grauguss Spheroidal graphite cast iron
AM = Ohne Keilnut Without keyway BM = Mit Keilnut With keyway

Taperbuchse Taper bush	1008	1210	1610	1615	2517	3030	3535	4040
Bohrung d ₂ (mm) von ... bis ... Bore d ₂ (mm) from ... to ...	10-25	11-32	14-42	14-42	16-60	35-75	35-90	40-100
€/Stück each	auf Anfrage / on request							

Bohrungsdurchmesser d₂ siehe Seite 3-4.
Bore diameters d₂ see page 3-4.

Weitere Abmessungen auf Anfrage.
Further sizes on request.

Fertigungstechnische Änderungen vorbehalten.
We reserve the right to make technical changes.

Spannelemente Clamping bushes

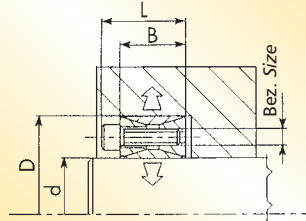

Type CE01

Bezeichnung Part No.	Abmessung Dimension				Schrauben Screws			Bei Anzugsmoment M_s übertragbar With tightening torque M_s applied		Flächen- pressung Pressure		Gewicht Weight	€/Stück each
								Drehmoment Torque	Axialkraft Axial force	Welle Shaft	Nabe Hub		
	d	D	B	L	Bezeichnung Part No.	Anzahl No.	Anzugs- moment Tightening torque M_s	M	F	P_w	P_N		
	(mm)	(mm)	(mm)	(mm)		Stück each	(Nm)	(Nm)	(kN)	(N/ mm ²)	(N/ mm ²)		
CE01- 18	18	47	20	26	M 6 x 18	8	16	250	28	240	92	0,210	auf Anfrage on request
CE01- 19	19	47	20	26	M 6 x 18	8	16	260	28	225	92	0,210	
CE01- 20	20	47	20	26	M 6 x 18	8	16	280	28	215	92	0,210	
CE01- 22	22	47	20	26	M 6 x 18	8	16	310	28	195	92	0,200	
CE01- 24	24	50	20	26	M 6 x 18	8	16	330	28	180	87	0,222	
CE01- 25	25	50	20	26	M 6 x 18	8	16	350	28	175	87	0,220	
CE01- 28	28	55	20	26	M 6 x 18	12	16	580	42	230	118	0,266	
CE01- 30	30	55	20	26	M 6 x 18	12	16	630	42	215	118	0,254	
CE01- 32	32	60	20	26	M 6 x 18	12	16	670	42	200	110	0,302	
CE01- 35	35	60	20	26	M 6 x 18	12	16	730	42	185	110	0,282	
CE01- 38	38	65	20	26	M 6 x 18	15	16	990	52	215	125	0,328	
CE01- 40	40	65	20	26	M 6 x 18	15	16	1040	52	200	125	0,318	
CE01- 42	42	75	24	32	M 8 x 22	12	38	1600	76	240	140	0,560	
CE01- 45	45	75	24	32	M 8 x 22	12	38	1700	76	225	140	0,528	
CE01- 48	48	80	24	32	M 8 x 22	12	38	1800	76	210	120	0,590	
CE01- 50	50	80	24	32	M 8 x 22	12	38	1900	76	200	130	0,560	
CE01- 55	55	85	24	32	M 8 x 22	15	38	2600	95	230	150	0,622	
CE01- 60	60	90	24	32	M 8 x 22	15	38	2850	95	210	140	0,660	
CE01- 65	65	95	24	32	M 8 x 22	15	38	3100	95	195	130	0,798	
CE01- 70	70	110	28	38	M10 x 25	15	75	5350	150	240	160	1,238	
CE01- 75	75	115	28	38	M10 x 25	15	75	5730	150	225	150	1,294	
CE01- 80	80	120	28	38	M10 x 25	15	75	6100	150	210	140	1,364	
CE01- 85	85	125	28	38	M10 x 25	15	75	6500	150	200	140	1,428	
CE01- 90	90	130	28	38	M10 x 25	15	75	6900	150	185	130	1,482	
CE01- 95	95	135	28	38	M10 x 25	18	75	8700	180	210	150	1,568	
CE01-100	100	145	30	42	M12 x 30	15	130	11200	220	230	160	2,154	
CE01-110	110	155	30	42	M12 x 30	15	130	12300	220	205	150	2,306	
CE01-120	120	165	30	42	M12 x 30	16	130	14300	240	200	150	2,486	
CE01-130	130	180	38	50	M12 x 35	20	130	19400	300	180	130	3,586	
CE01-140	140	190	38	50	M12 x 35	22	130	23000	330	180	140	3,810	
CE01-150	150	200	38	50	M12 x 35	24	130	26900	360	185	140	4,084	
CE01-160	160	210	38	50	M12 x 35	26	130	31000	390	190	150	4,360	
CE01-170	170	225	44	58	M14 x 40	22	200	36300	430	175	140	5,700	
CE01-180	180	235	44	58	M14 x 40	24	200	42000	470	180	140	6,000	
CE01-190	190	250	52	66	M14 x 45	28	200	51800	550	165	130	8,000	
CE01-200	200	260	52	66	M14 x 45	30	200	58300	590	165	130	8,200	
CE01-220	220	285	56	72	M16 x 50	26	300	74100	680	160	130	11,000	
CE01-240	240	305	56	72	M16 x 50	30	300	93200	780	170	140	12,300	
CE01-260	260	325	56	72	M16 x 50	34	300	114500	890	180	150	13,000	
CE01-280	280	355	66	84	M18 x 60	32	410	141000	1000	160	130	19,000	
CE01-300	300	375	66	84	M18 x 60	36	410	170000	1140	165	140	20,200	
CE01-320	320	405	78	98	M20 x 70	36	590	235500	1500	170	140	30,600	
CE01-340	340	425	78	98	M20 x 70	36	590	250000	1500	160	130	30,800	
CE01-360	360	455	90	112	M22 x 80	36	790	329000	1800	160	130	43,200	
CE01-380	380	475	90	112	M22 x 80	36	790	346400	1800	150	120	45,000	
CE01-400	400	495	90	112	M22 x 80	36	790	365000	1800	145	120	46,800	

Fertigungstechnische Änderungen vorbehalten. We reserve the right to make technical changes.

Spannelemente Clamping bushes

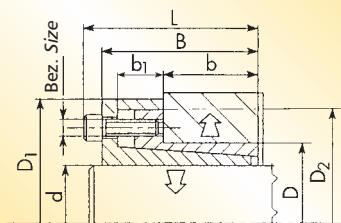

Type CE02

Bezeichnung Part No.	Abmessung Dimension								Schrauben Screws			Bei Anzugsmoment M_s übertragbar With tightening torque M_s applied		Flächen- pression Pressure		Gewicht Weight	€/Stück each
	d	D	D ₁	D ₂	b	b ₁	B	L	Bezeichnung Part No.	An- zahl No.	Anzugs- moment Tighten- ing torque M_s	Drehmoment Torque	Axialkraft Axial force	Welle Shaft	Nabe Hub		
																M	
	(mm)	(mm)	(mm)	(mm)	(mm)	(mm)	(mm)	(mm)	Stück each	(Nm)	(Nm)	(kN)	(N/ mm ²)	(N/ mm ²)	(kg)		
CE02- 6	6	14	25	23	9	9,5	21,5	24,5	M 3 x 10	4	2	14	4,8	103	95	0,080	
CE02- 8	8	15	27	24	12	10,0	25,0	29,0	M 4 x 10	3	5	28	7,0	104	101	0,100	
CE02- 10	10	16	29	26	14	8,5	26,0	30,0	M 4 x 10	4	5	46	9,0	110	108	0,120	
CE02- 12	12	18	32	28	14	8,5	26,0	30,0	M 4 x 10	4	5	55	9,0	88	96	0,140	
CE02- 14	14	23	38	33	14	8,5	26,0	30,0	M 4 x 10	4	5	64	9,0	75	75	0,150	
CE02- 15	15	24	45	40	16	12,5	36,0	42,0	M 6 x 16	4	15	150	19,0	102	132	0,209	
CE02- 16	16	24	45	40	16	12,5	36,0	42,0	M 6 x 16	4	15	150	19,0	96	132	0,218	
CE02- 18	18	26	47	43	18	13,0	38,0	44,0	M 6 x 18	4	17	200	23,0	102	129	0,226	
CE02- 19	19	27	49	44	18	13,0	38,0	44,0	M 6 x 18	4	17	210	23,0	97	125	0,248	
CE02- 20	20	28	49	44	18	13,0	38,0	44,0	M 6 x 18	4	17	220	23,0	92	120	0,248	
CE02- 22	22	32	54	49	25	13,0	45,0	51,0	M 6 x 18	4	17	250	23,0	69	76	0,325	
CE02- 24	24	34	56	51	25	13,0	45,0	51,0	M 6 x 18	4	17	270	23,0	63	71	0,344	
CE02- 25	25	34	56	51	25	13,0	45,0	51,0	M 6 x 18	4	17	280	23,0	61	71	0,332	
CE02- 28	28	39	61	56	25	13,0	45,0	51,0	M 6 x 18	6	17	500	34,0	81	93	0,410	
CE02- 30	30	41	62	57	25	13,0	45,0	51,0	M 6 x 18	6	17	520	34,0	76	89	0,414	
CE02- 32	32	43	65	59	30	13,0	50,0	56,0	M 6 x 18	8	17	730	46,0	84	94	0,478	
CE02- 35	35	47	69	64	30	13,0	50,0	56,0	M 6 x 18	8	17	800	46,0	77	86	0,546	
CE02- 38	38	50	72	67	30	13,0	50,0	56,0	M 6 x 18	8	17	900	46,0	71	81	0,580	
CE02- 40	40	53	75	70	30	13,0	50,0	56,0	M 6 x 18	8	17	900	46,0	67	76	0,626	
CE02- 42	42	55	78	73	40	17,0	65,0	73,0	M 8 x 22	8	41	1800	84,0	89	101	0,880	
CE02- 45	45	59	85	79	40	17,0	65,0	73,0	M 8 x 22	8	41	1900	84,0	84	94	1,028	
CE02- 48	48	62	87	82	45	17,0	70,0	78,0	M 8 x 22	8	41	2000	84,0	72	79	0,980	
CE02- 50	50	65	92	85	45	17,0	70,0	78,0	M 8 x 22	10	41	2600	105,0	87	95	1,270	
CE02- 55	55	71	98	92	50	17,0	75,0	83,0	M 8 x 22	10	41	2900	105,0	73	78	1,480	
CE02- 60	60	77	104	98	50	17,0	75,0	83,0	M 8 x 22	10	41	3100	105,0	67	72	1,658	
CE02- 65	65	84	111	105	50	17,0	75,0	83,0	M 8 x 22	10	41	3400	105,0	62	66	1,922	
CE02- 70	70	90	119	114	60	20,0	91,0	101,0	M10 x 25	10	83	5800	170,0	91	82	2,936	
CE02- 75	75	95	126	120	60	20,0	91,0	101,0	M10 x 25	10	83	6200	170,0	70	77	2,290	
CE02- 80	80	100	131	125	65	20,0	96,0	106,0	M10 x 25	12	83	7800	200,0	74	81	3,342	
CE02- 85	85	106	137	131	65	20,0	96,0	106,0	M10 x 25	12	83	8500	200,0	70	77	3,622	
CE02- 90	90	112	143	137	65	20,0	96,0	106,0	M10 x 25	15	83	11200	250,0	83	91	3,956	
CE02- 95	95	120	153	146	65	20,0	96,0	106,0	M10 x 25	15	83	11800	250,0	78	85	4,460	
CE02-100	100	125	162	155	65	24,0	102,0	114,0	M12 x 30	12	145	14600	300,0	82	95	6,000	

auf
Anfrage
on
request

Spannelemente Clamping bushes

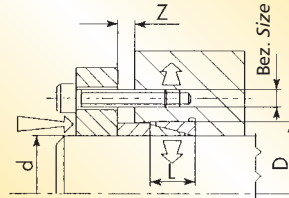

Type CE03

Bezeichnung Part No.	Abmessung Dimension							Bei Anzugsmoment M_t übertragbar With tightening torque M_t applied		Flächen- pressung Pressure		Ges. Axialkraft der Spann- schrauben Total axial force on the tension screws	Gewicht Weight	€/Stück each
	d	D	L	Z				Drehmoment Torque	Axialkraft Axial force	Welle Shaft	Nabe Hub			
				1	2	3	4					M	F	
	(mm)	(mm)	(mm)	(mm)	(mm)	(mm)	(mm)	(mm)	(Nm)	(K_N)	(N/mm^2)	(N/mm^2)	(K_N)	
CE03- 6	6	9	4,5	3	3	3	4	2	0,8	96	65	4	0,001	
CE03- 8	8	11	4,5	3	3	3	4	5	1,0	108	80	6	0,001	
CE03- 10	10	13	4,5	3	3	3	4	10	2,0	112	100	16	0,002	
CE03- 12	12	15	4,5	3	3	3	4	11	2,0	111	90	16	0,002	
CE03- 14	14	18	6,3	3	4	4	5	22	3,0	112	90	26	0,004	
CE03- 15	15	19	6,3	3	4	4	5	25	3,0	112	90	27	0,004	
CE03- 16	16	20	6,3	3	4	4	5	26	3,0	112	90	27	0,005	
CE03- 17	17	21	6,3	3	4	4	5	30	3,0	112	90	27	0,006	
CE03- 18	18	22	6,3	3	4	4	5	33	3,0	112	90	33	0,006	
CE03- 19	19	24	6,3	3	4	4	5	40	4,0	112	90	33	0,006	
CE03- 20	20	25	6,3	3	4	4	5	44	4,0	112	90	33	0,008	
CE03- 22	22	26	6,3	3	4	4	5	50	4,0	100	90	34	0,010	
CE03- 24	24	28	6,3	3	4	4	5	68	6,0	114	100	34	0,006	
CE03- 25	25	30	6,3	3	4	4	5	75	6,0	120	100	37	0,010	
CE03- 28	28	32	6,3	3	4	4	5	90	6,0	111	100	40	0,008	
CE03- 30	30	35	6,3	3	4	4	5	100	7,0	111	100	40	0,012	
CE03- 32	32	36	6,3	3	4	4	5	120	7,0	111	100	40	0,010	
CE03- 35	35	40	7,0	3	4	4	5	160	9,0	111	100	50	0,015	
CE03- 38	38	44	7,0	4	5	5	6	190	10,0	111	100	60	0,020	
CE03- 40	40	45	8,0	4	5	5	6	230	11,0	111	100	70	0,020	
CE03- 42	42	48	8,0	4	5	5	6	260	12,0	111	100	70	0,025	
CE03- 45	45	52	10,0	4	5	5	6	390	17,0	111	100	110	0,039	
CE03- 48	48	55	10,0	4	5	5	6	430	18,0	111	100	110	0,042	
CE03- 50	50	57	10,0	4	5	5	6	470	19,0	111	100	110	0,044	
CE03- 55	55	62	10,0	4	5	5	6	580	21,0	111	100	120	0,048	
CE03- 60	60	68	12,0	4	5	6	7	840	28,0	111	100	160	0,072	
CE03- 65	65	73	12,0	4	5	6	7	1000	30,0	111	100	160	0,078	
CE03- 70	70	79	14,0	4	5	6	7	1300	38,0	111	100	200	0,112	
CE03- 75	75	84	14,0	4	5	6	7	1500	41,0	111	100	220	0,120	
CE03- 80	80	91	17,0	5	6	7	8	2100	54,0	111	100	300	0,190	
CE03- 85	85	96	17,0	5	6	7	8	2300	56,0	111	100	310	0,200	
CE03- 90	90	101	17,0	5	6	7	8	2700	61,0	111	100	320	0,212	
CE03- 95	95	106	17,0	5	6	7	8	3500	73,0	111	100	380	0,230	
CE03-100	100	114	21,0	5	6	8	9	4200	84,0	111	100	440	0,376	
CE03-110	110	124	21,0	5	6	8	9	4300	86,0	111	90	450	0,410	
CE03-120	120	134	21,0	5	6	8	9	5100	88,0	111	90	460	0,450	
CE03-130	130	148	28,0	6	7	9	11	8100	125,0	111	90	650	0,828	
CE03-140	140	158	28,0	6	7	9	11	9400	135,0	111	90	690	0,898	
CE03-150	150	168	28,0	6	7	9	11	11000	145,0	111	90	720	0,973	

auf
Anfrage
on
request

Spannelemente Clamping bushes

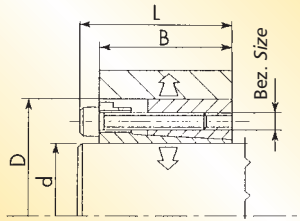

Type CE04

Bezeichnung Part No.	Abmessung Dimension				Schrauben Screws			Bei Anzugsmoment M_s übertragbar With tightening torque M_s applied		Flächen- pressung Pressure		Gewicht Weight	€/Stück each
								Drehmoment Torque	Axialkraft Axial force	Welle Shaft	Nabe Hub		
	d	D	B	L	Bezeichnung Part No.	Anzahl No.	Anzugs- moment Tightening torque M_s	M	F	P_w	P_N		
	(mm)	(mm)	(mm)	(mm)		Stück each	(Nm)	(Nm)	(kN)	(N/ mm ²)	(N/ mm ²)		
CE04- 20	20	47	42	48	M 6 x 25	6	17	530	52	190	110	0,384	auf Anfrage on request
CE04- 22	22	47	42	48	M 6 x 25	6	17	580	52	170	110	0,366	
CE04- 24	24	50	42	48	M 6 x 25	6	17	630	52	160	100	0,410	
CE04- 25	25	50	42	48	M 6 x 25	6	17	660	52	150	100	0,402	
CE04- 28	28	55	42	48	M 6 x 25	6	17	740	52	130	100	0,482	
CE04- 30	30	55	42	48	M 6 x 25	6	17	790	52	130	100	0,458	
CE04- 32	32	60	42	48	M 6 x 25	8	17	1180	70	160	120	0,520	
CE04- 35	35	60	42	48	M 6 x 25	8	17	1230	70	140	120	0,510	
CE04- 38	38	65	42	48	M 6 x 25	8	17	1300	70	130	110	0,600	
CE04- 40	40	65	42	48	M 6 x 25	8	17	1400	70	125	110	0,568	
CE04- 42	42	75	50	58	M 8 x 30	6	41	2000	100	130	120	1,020	
CE04- 45	45	75	50	58	M 8 x 30	6	41	2200	100	125	120	0,934	
CE04- 48	48	80	50	58	M 8 x 30	8	41	3200	130	155	150	1,050	
CE04- 50	50	80	50	58	M 8 x 30	8	41	3300	130	150	150	1,008	
CE04- 55	55	85	50	58	M 8 x 30	8	41	3600	130	135	140	1,124	
CE04- 60	60	90	50	58	M 8 x 30	8	41	3900	130	125	130	1,210	
CE04- 65	65	95	50	58	M 8 x 30	8	41	4200	130	115	120	1,234	
CE04- 70	70	110	60	70	M10 x 30	8	83	7500	210	150	130	2,306	
CE04- 75	75	115	60	70	M10 x 30	8	83	8000	210	140	130	2,466	
CE04- 80	80	120	60	70	M10 x 30	8	83	8500	210	130	120	2,588	
CE04- 85	85	125	60	70	M10 x 30	10	83	11400	270	155	150	2,700	
CE04- 90	90	130	60	70	M10 x 30	10	83	12000	270	145	140	2,832	
CE04-100	100	145	68	80	M12 x 35	8	145	15000	300	130	120	3,936	
CE04-110	110	155	68	80	M12 x 35	8	145	16500	300	120	110	4,300	
CE04-120	120	165	68	80	M12 x 35	10	145	22500	370	135	130	4,600	
CE04-130	130	180	68	80	M12 x 35	12	145	29300	450	150	140	5,500	
CE04-140	140	190	76	90	M14 x 40	10	210	32200	460	130	125	6,700	
CE04-150	150	200	76	90	M14 x 40	12	210	41400	550	145	140	7,000	
CE04-160	160	210	76	90	M14 x 40	12	210	44100	550	135	130	7,500	
CE04-170	170	225	76	90	M14 x 40	14	210	54700	640	150	150	8,700	
CE04-180	180	235	76	90	M14 x 40	14	210	57900	640	140	140	9,200	

Fertigungstechnische Änderungen vorbehalten. We reserve the right to make technical changes.

Spannelemente Clamping bushes

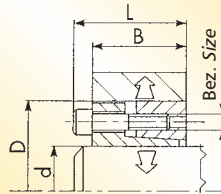

Type CE05

Bezeichnung Part No.	Abmessung Dimension				Schrauben Screws			Bei Anzugsmoment M_s übertragbar With tightening torque M_s applied		Flächen- pressung Pressure		Gewicht Weight	€/Stück each
								Drehmoment Torque	Axialkraft Axial force	Welle Shaft	Nabe Hub		
	d	D	B	L	Bezeichnung Part No.	Anzahl No.	Anzugs- moment Tightening torque M_s	M	F	P_w	P_N		
	(mm)	(mm)	(mm)	(mm)		Stück each	(Nm)	(Nm)	(kN)	(N/ mm ²)	(N/ mm ²)		
CE05- 20	20	47	28	34	M 6 x 20	6	14	410	41	218	137	0,260	auf Anfrage on request
CE05- 22	22	47	28	34	M 6 x 20	6	14	450	41	198	137	0,250	
CE05- 24	24	50	28	34	M 6 x 20	6	14	490	41	182	128	0,276	
CE05- 25	25	50	28	34	M 6 x 20	6	14	510	41	175	128	0,268	
CE05- 28	28	55	28	34	M 6 x 20	6	14	570	41	156	117	0,322	
CE05- 30	30	55	28	34	M 6 x 20	6	14	610	41	145	117	0,304	
CE05- 32	32	60	28	34	M 6 x 20	8	14	880	54	182	143	0,370	
CE05- 35	35	60	28	34	M 6 x 20	8	14	960	54	166	143	0,344	
CE05- 38	38	65	28	34	M 6 x 20	8	14	1040	54	153	132	0,408	
CE05- 40	40	65	28	34	M 6 x 20	8	14	1090	54	145	132	0,378	
CE05- 42	42	75	33	41	M 8 x 25	8	35	2200	105	201	186	0,630	
CE05- 45	45	75	33	41	M 8 x 25	8	35	2360	105	207	186	0,630	
CE05- 48	48	80	33	41	M 8 x 25	8	35	2520	105	194	174	0,680	
CE05- 50	50	80	33	41	M 8 x 25	8	35	2620	105	186	174	0,686	
CE05- 55	55	85	33	41	M 8 x 25	8	35	2890	105	169	164	0,720	
CE05- 60	60	90	33	41	M 8 x 25	8	35	3150	105	155	155	0,794	
CE05- 65	65	95	33	41	M 8 x 25	8	35	3410	105	143	174	0,842	
CE05- 70	70	110	40	50	M10 x 30	8	70	5990	170	180	172	1,534	
CE05- 75	75	115	40	50	M10 x 30	8	70	6420	170	168	165	1,634	
CE05- 80	80	120	40	50	M10 x 30	8	70	6850	170	158	158	1,722	
CE05- 85	85	125	40	50	M10 x 30	10	70	9090	210	186	189	1,834	
CE05- 90	90	130	40	50	M10 x 30	10	70	9630	210	175	182	1,900	
CE05-100	100	145	44	56	M12 x 30	8	115	11900	240	158	168	2,618	
CE05-110	110	155	44	56	M12 x 30	8	115	13090	240	144	157	2,788	
CE05-120	120	165	44	56	M12 x 30	9	115	16060	270	148	166	3,600	
CE05-130	130	180	52	64	M12 x 30	12	115	23200	360	152	155	4,410	
CE05-140	140	190	54	68	M14 x 40	9	185	25500	360	138	150	4,920	
CE05-150	150	200	54	68	M14 x 40	10	185	30300	400	143	158	5,200	
CE05-160	160	210	54	68	M14 x 40	12	185	38800	490	161	181	5,600	
CE05-180	180	235	64	78	M14 x 40	12	185	43700	490	119	125	8,500	
CE05-200	200	260	64	78	M14 x 40	15	185	60700	610	134	141	9,600	

Spannelemente Clamping bushes

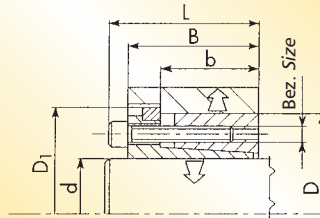

Type CE06

Bezeichnung Part No.	Abmessung Dimension						Schrauben Screws			Bei Anzugsmoment M_s übertragbar With tightening torque M_s applied		Flächen- pression Pressure		Gewicht Weight	€/Stück each
										Drehmoment Torque	Axialkraft Axial force	Welle Shaft	Nabe Hub		
	d	D	D ₁	b	B	L	Bezeichnung Part No.	Anzahl No.	Anzugs- moment Tighten- ing torque M_s	M	F	P _w	P _N		
	(mm)	(mm)	(mm)	(mm)	(mm)	(mm)		Stück each	(Nm)	(Nm)	(K _N)	(N/ mm ²)	(N/ mm ²)		
CE06- 20	20	47	53	31,0	42	48	M 6 x 25	6	17	320	33	116	70	0,416	
CE06- 22	22	47	53	31,0	42	48	M 6 x 25	6	17	360	33	105	70	0,398	
CE06- 24	24	50	56	31,0	42	48	M 6 x 25	6	17	390	33	97	70	0,442	
CE06- 25	25	50	56	31,0	42	48	M 6 x 25	6	17	400	33	93	70	0,434	
CE06- 28	28	55	61	31,0	42	48	M 6 x 25	6	17	450	33	83	60	0,516	
CE06- 30	30	55	61	31,0	42	48	M 6 x 25	6	17	490	33	77	60	0,492	
CE06- 32	32	60	66	31,0	42	48	M 6 x 25	8	17	690	43	97	70	0,560	
CE06- 35	35	60	66	31,0	42	48	M 6 x 25	8	17	750	43	88	70	0,548	
CE06- 38	38	65	71	31,0	42	48	M 6 x 25	8	17	820	43	81	70	0,650	
CE06- 40	40	65	71	31,0	42	48	M 6 x 25	8	17	860	43	77	70	0,608	
CE06- 42	42	75	81	36,0	50	58	M 8 x 30	6	41	1250	60	82	70	1,090	
CE06- 45	45	75	81	36,0	50	58	M 8 x 30	6	41	1340	60	77	70	1,004	
CE06- 48	48	80	86	36,0	50	58	M 8 x 30	8	41	1910	80	96	90	1,100	
CE06- 50	50	80	86	36,0	50	58	M 8 x 30	8	41	1990	80	92	90	1,074	
CE06- 55	55	85	91	36,0	50	58	M 8 x 30	8	41	2200	80	84	90	1,204	
CE06- 60	60	90	96	36,0	50	58	M 8 x 30	8	41	2400	80	77	80	1,292	
CE06- 65	65	95	101	36,0	50	58	M 8 x 30	8	41	2600	80	71	70	1,308	
CE06- 70	70	110	119	46,0	60	70	M10 x 30	8	83	4600	130	92	80	2,440	
CE06- 75	75	115	124	46,0	60	70	M10 x 30	8	83	4930	130	86	80	2,596	
CE06- 80	80	120	129	46,0	60	70	M10 x 30	8	83	5200	130	81	70	2,730	
CE06- 85	85	125	134	46,0	60	70	M10 x 30	10	83	7000	165	95	90	2,800	
CE06- 90	90	130	139	46,0	60	70	M10 x 30	10	83	7400	165	90	80	2,986	
CE06-100	100	145	155	52,0	68	80	M12 x 35	8	145	9700	190	84	80	4,136	
CE06-110	110	155	165	52,0	68	80	M12 x 35	8	145	10680	190	77	70	4,500	
CE06-120	120	165	175	52,0	68	80	M12 x 35	10	145	14500	240	88	90	4,800	
CE06-130	130	180	188	52,0	68	80	M12 x 35	12	145	18900	290	97	100	5,800	
CE06-140	140	190	199	58,5	76	90	M14 x 40	10	230	22800	325	91	90	7,000	
CE06-150	150	200	209	58,5	76	90	M14 x 40	12	230	29300	390	102	100	7,300	
CE06-160	160	210	219	58,5	76	90	M14 x 40	12	230	31300	390	95	100	7,800	
CE06-170	170	225	234	58,5	76	90	M14 x 40	14	230	38800	460	105	110	9,600	
CE06-180	180	235	244	58,5	76	90	M14 x 40	14	230	41000	460	99	100	9,000	

auf
Anfrage
on
request

Spannelemente Clamping bushes

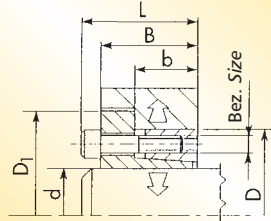

Type CE07

Bezeichnung Part No.	Abmessung Dimension						Schrauben Screws			Bei Anzugsmoment M_s übertragbar With tightening torque M_s applied		Flächen- pression Pressure		Gewicht Weight	€/Stück each
										Drehmoment Torque	Axialkraft Axial force	Welle Shaft	Nabe Hub		
	d	D	D ₁	b	B	L	Bezeichnung Part No.	Anzahl No.	Anzugs- moment Tighten- ing torque M_s	M	F	P _W	P _N		
	(mm)	(mm)	(mm)	(mm)	(mm)	(mm)		Stück each	(Nm)	(Nm)	(kN)	(N/ mm ²)	(N/ mm ²)		
CE07- 20	20	47	56	22	28	34	M 6 x 20	6	17	320	32	171	100	0,280	
CE07- 22	22	47	56	22	28	34	M 6 x 20	6	17	350	32	156	100	0,270	
CE07- 24	24	50	59	22	28	34	M 6 x 20	6	17	390	32	143	100	0,310	
CE07- 25	25	50	59	22	28	34	M 6 x 20	6	17	400	32	137	100	0,304	
CE07- 28	28	55	64	22	28	34	M 6 x 20	6	17	450	32	122	90	0,362	
CE07- 30	30	55	64	22	28	34	M 6 x 20	6	17	490	32	114	90	0,346	
CE07- 32	32	60	69	22	28	34	M 6 x 20	8	17	700	43	143	110	0,420	
CE07- 35	35	60	69	22	28	34	M 6 x 20	8	17	760	43	131	110	0,390	
CE07- 38	38	65	74	22	28	34	M 6 x 20	8	17	820	43	120	100	0,454	
CE07- 40	40	65	74	22	28	34	M 6 x 20	8	17	870	43	114	100	0,446	
CE07- 42	42	75	84	25	33	41	M 8 x 25	6	41	1700	80	168	140	0,440	
CE07- 45	45	75	84	25	33	41	M 8 x 25	6	41	1800	80	157	140	0,696	
CE07- 48	48	80	89	25	33	41	M 8 x 25	8	41	1900	80	147	130	0,800	
CE07- 50	50	80	89	25	33	41	M 8 x 25	8	41	2000	80	141	130	0,756	
CE07- 55	55	85	91	25	33	41	M 8 x 25	8	41	2200	80	128	120	0,850	
CE07- 60	60	90	99	25	33	41	M 8 x 25	8	41	2400	80	117	120	0,900	
CE07- 65	65	95	104	25	33	41	M 8 x 25	8	41	2600	80	108	110	0,934	
CE07- 70	70	110	119	30	40	50	M10 x 30	8	83	4600	130	138	130	1,670	
CE07- 75	75	115	124	30	40	50	M10 x 30	8	83	5000	130	129	130	1,760	
CE07- 80	80	120	129	30	40	50	M10 x 30	8	83	5300	130	121	120	1,868	
CE07- 85	85	125	134	30	40	50	M10 x 30	10	83	7000	160	142	150	1,966	
CE07- 90	90	130	139	30	40	50	M10 x 30	10	83	7400	160	135	140	2,046	
CE07-100	100	145	154	32	44	56	M12 x 30	8	145	9700	200	129	140	2,830	
CE07-110	110	155	164	32	44	56	M12 x 30	8	145	10700	200	117	130	3,100	
CE07-120	120	165	174	32	44	56	M12 x 30	9	145	13100	220	121	140	3,284	
CE07-130	130	180	189	40	52	64	M12 x 30	12	145	19000	290	124	130	4,600	
CE07-140	140	190	199	40	54	68	M14 x 40	9	230	20500	300	111	120	4,980	
CE07-150	150	200	209	40	54	68	M14 x 40	10	230	24500	330	115	130	5,200	
CE07-160	160	210	219	40	54	68	M14 x 40	12	230	31300	390	130	150	5,600	
CE07-180	180	235	244	50	64	78	M14 x 40	12	230	35000	390	96	100	8,500	
CE07-200	200	260	269	50	64	78	M14 x 40	15	230	49000	500	108	110	9,600	

auf
Anfrage
on
request

Spannelemente Clamping bushes

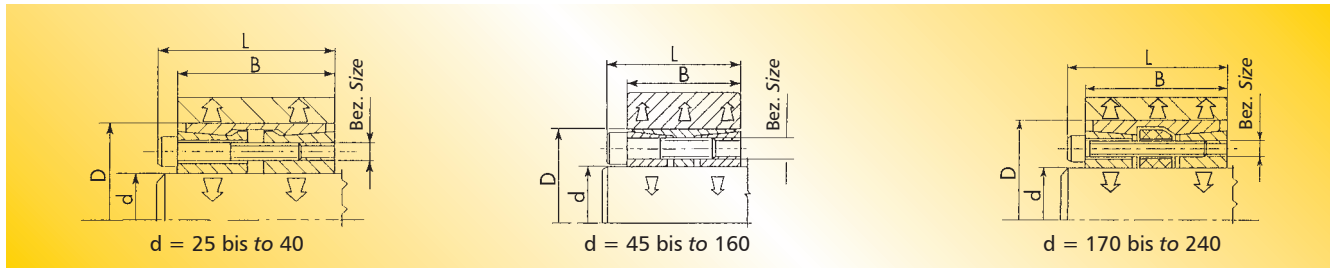

Type CE08

Bezeichnung Part No.	Abmessung Dimension				Schrauben Screws			Bei Anzugsmoment M_s übertragbar With tightening torque M_s applied		Flächen- pression Pressure		Gewicht Weight	€/Stück each
								Drehmoment Torque	Axialkraft Axial force	Welle Shaft	Nabe Hub		
	d	D	B	L	Bezeichnung Part No.	Anzahl No.	Anzugs- moment Tightening torque M_s	M	F	P_W	P_N		
	(mm)	(mm)	(mm)	(mm)		Stück each	(Nm)	(Nm)	(K _N)	(N/ mm ²)	(N/ mm ²)		
CE08- 25	25	50	45	51	M 6 x 35	6	17	700	55	157	80	0,415	auf Anfrage on request
CE08- 30	30	55	45	51	M 6 x 35	8	17	1200	70	175	90	0,464	
CE08- 35	35	60	45	51	M 6 x 35	8	17	1400	70	150	90	0,526	
CE08- 40	40	65	45	51	M 6 x 35	10	17	2000	90	164	100	0,550	
CE08- 45	45	75	45	53	M 8 x 35	8	41	3200	140	216	130	0,768	
CE08- 50	50	80	64	72	M 8 x 55	8	41	3600	140	165	80	1,326	
CE08- 55	55	85	64	72	M 8 x 55	8	41	4000	140	150	80	1,430	
CE08- 60	60	90	64	72	M 8 x 55	10	41	5400	170	171	90	1,524	
CE08- 65	65	95	64	72	M 8 x 55	10	41	5800	170	158	90	2,000	
CE08- 70	70	110	78	88	M10 x 60	10	83	10300	280	199	100	2,932	
CE08- 75	75	115	78	88	M10 x 60	10	83	11000	280	186	100	3,100	
CE08- 80	80	120	78	88	M10 x 60	12	83	14000	340	209	110	3,300	
CE08- 85	85	125	78	88	M10 x 60	12	83	15000	340	197	110	3,400	
CE08- 90	90	130	78	88	M10 x 60	12	83	16000	340	186	100	3,600	
CE08- 95	95	135	78	88	M10 x 60	12	83	17000	340	176	100	4,000	
CE08-100	100	145	100	112	M12 x 80	12	145	26000	500	198	100	6,000	
CE08-110	110	155	100	112	M12 x 80	12	145	29000	500	180	100	6,000	
CE08-120	120	165	100	112	M12 x 80	14	145	36400	600	192	110	6,000	
CE08-130	130	180	116	130	M14 x 90	12	230	45400	700	174	100	10,100	
CE08-140	140	190	116	130	M14 x 90	14	230	57000	800	189	110	10,500	
CE08-150	150	200	116	130	M14 x 90	16	230	70000	900	201	120	11,000	
CE08-160	160	210	116	130	M14 x 90	16	230	75000	900	189	110	12,000	
CE08-170	170	225	146	162	M16 x 110	14	355	95000	1100	168	100	17,000	
CE08-180	180	235	146	162	M16 x 110	15	355	115000	1200	182	110	18,400	
CE08-190	190	250	146	162	M16 x 110	16	355	121500	1200	172	100	21,400	
CE08-200	200	260	146	162	M16 x 110	16	355	128000	1200	163	100	21,800	

Fertigungstechnische Änderungen vorbehalten. We reserve the right to make technical changes.

Spannelemente Clamping bushes

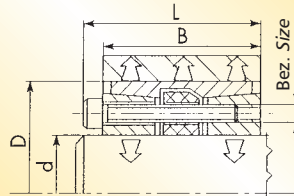

Type CE09

Bezeichnung Part No.	Abmessung Dimension				Schrauben Screws			Bei Anzugsmoment M_s übertragbar With tightening torque M_s applied		Flächen- pression Pressure		Gewicht Weight	€/Stück each
								Drehmoment Torque	Axialkraft Axial force	Welle Shaft	Nabe Hub		
	d	D	B	L	Bezeichnung Part No.	Anzahl No.	Anzugs- moment Tightening torque M_s	M	F	P_w	P_N		
	(mm)	(mm)	(mm)	(mm)		Stück each	(Nm)	(Nm)	(kN)	(N/ mm ²)	(N/ mm ²)		
CE09- 45	45	75	64	72	M 8 x 55	8	41	3200	120	210	125	1,000	auf Anfrage on request
CE09- 50	50	80	78	86	M 8 x 65	8	41	3550	120	140	65	1,500	
CE09- 60	60	90	78	86	M 8 x 65	10	41	5330	150	146	75	2,000	
CE09- 70	70	110	102	112	M10 x 90	10	83	10260	250	147	75	4,000	
CE09- 80	80	120	102	112	M10 x 90	12	83	14000	300	154	85	5,000	
CE09- 90	90	130	102	112	M10 x 90	12	83	15800	300	137	75	6,000	
CE09-100	100	145	122	134	M12 x 110	12	145	26000	450	149	85	7,000	

Spannelemente Clamping bushes

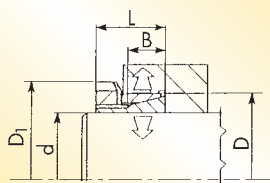

Type CE10

Bezeichnung Part No.	Abmessung Dimension					Schrauben Screws			Bei Anzugsmoment M_s übertragbar With tightening torque M_s applied		Flächen- pression Pressure		Gewicht Weight	€/Stück each
									Drehmoment Torque	Axialkraft Axial force	Welle Shaft	Nabe Hub		
	d	D	D_1	B	L	Bezeichnung Part No.	Anzahl No.	Anzugs- moment Tighten- ing torque M_s	M	F	P_W	P_N		
	(mm)	(mm)	(mm)	(mm)	(mm)		Stück each	(Nm)	(Nm)	(K_N)	(N/mm^2)	(N/mm^2)		
CE10-14	14	25	32	6,5	16,5	M20 x 1,5	1	65	37	6	171	73	0,052	
CE10-15	15	25	32	6,5	16,5	M20 x 1,5	1	65	40	6	159	73	0,050	
CE10-16	16	25	32	6,5	16,5	M20 x 1,5	1	65	42	6	149	73	0,048	
CE10-18	18	30	38	7,0	17,0	M25 x 1,5	1	85	65	8	168	80	0,080	
CE10-19	19	30	38	7,0	17,0	M25 x 1,5	1	95	60	7	136	70	0,078	
CE10-20	20	30	38	7,0	17,0	M25 x 1,5	1	110	70	8	149	80	0,074	
CE10-24	24	35	45	7,0	17,0	M30 x 1,5	1	155	100	10	147	80	0,100	
CE10-25	25	35	45	7,0	17,0	M30 x 1,5	1	160	110	10	146	90	0,092	
CE10-28	28	40	52	8,0	20,0	M35 x 1,5	1	200	140	11	126	70	0,140	
CE10-30	30	40	52	8,0	20,0	M35 x 1,5	1	240	170	14	138	80	0,130	
CE10-32	32	45	58	9,0	22,0	M40 x 1,5	1	320	210	15	135	80	0,170	
CE10-35	35	45	58	9,0	22,0	M40 x 1,5	1	320	230	15	123	80	0,168	
CE10-40	40	50	64	9,0	23,0	M45 x 1,5	1	440	330	19	132	90	0,216	
CE10-45	45	55	70	10,0	25,5	M50 x 1,5	1	550	440	23	127	90	0,266	
CE10-50	50	60	75	10,0	25,5	M55 x 1,5	1	660	530	25	125	90	0,278	
CE10-60	60	70	85	12,0	29,5	M65 x 1,5	1	900	830	32	112	80	0,390	

auf
Anfrage
on
request

Spannelemente Clamping bushes

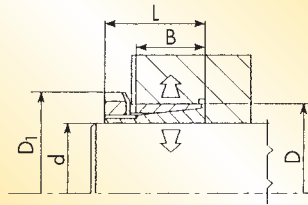

Type CE11

Bezeichnung Part No.	Abmessung Dimension					Schrauben Screws			Bei Anzugsmoment M_s übertragbar With tightening torque M_s applied		Flächen- pression Pressure		Gewicht Weight	
									Drehmoment Torque	Axialkraft Axial force	Welle Shaft	Nabe Hub		
	d	D	D ₁	B	L	Bezeichnung Part No.	Anzahl No.	Anzugs- moment Tighten- ing torque M_s	M	F	P _w	P _N		
	(mm)	(mm)	(mm)	(mm)	(mm)		Stück each	(Nm)	(Nm)	(kN)	(N/ mm ²)	(N/ mm ²)		
CE11-14	14	25	32	17	29	M20 x 1,5	1	90	90	15	145	80	0,080	auf Anfrage on request
CE11-15	15	25	32	17	29	M20 x 1,5	1	90	100	15	136	80	0,074	
CE11-16	16	25	32	17	29	M20 x 1,5	1	70	80	12	99	60	0,072	
CE11-18	18	30	38	18	31	M25 x 1,5	1	190	200	25	179	110	0,120	
CE11-19	19	30	38	18	31	M25 x 1,5	1	150	170	20	134	90	0,114	
CE11-20	20	30	38	18	31	M25 x 1,5	1	110	130	15	93	60	0,104	
CE11-24	24	35	45	22	35	M30 x 1,5	1	230	270	26	112	80	0,162	
CE11-25	25	35	45	22	35	M30 x 1,5	1	170	200	19	80	60	0,150	
CE11-28	28	40	52	22	35	M35 x 1,5	1	390	460	38	141	110	0,214	
CE11-30	30	40	52	22	35	M35 x 1,5	1	240	300	24	63	70	0,192	
CE11-32	32	45	58	27	42	M40 x 1,5	1	320	420	31	80	70	0,280	
CE11-35	35	45	58	28	42	M40 x 1,5	1	320	460	31	70	60	0,270	
CE11-40	40	50	64	28	44	M45 x 1,5	1	440	640	37	75	70	0,330	
CE11-45	45	55	70	28	45	M50 x 1,5	1	550	760	40	71	60	0,386	
CE11-50	50	60	75	28	46	M50 x 1,5	1	660	930	44	70	60	0,408	
CE11-60	60	70	85	28	52	M65 x 1,5	1	1050	1500	59	79	70	0,550	

Spannelemente Clamping bushes

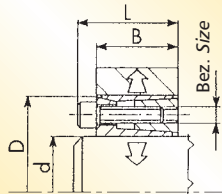

Type CE12

Bezeichnung Part No.	Abmessung Dimension				Schrauben Screws			Bei Anzugsmoment M_s übertragbar With tightening torque M_s applied		Flächen- pressung Pressure		Gewicht Weight	€/Stück each
								Drehmoment Torque	Axialkraft Axial force	Welle Shaft	Nabe Hub		
	d	D	B	L	Bezeichnung Part No.	Anzahl No.	Anzugs- moment Tightening torque M_s	M	F	P_W	P_N		
	(mm)	(mm)	(mm)	(mm)		Stück each	(Nm)	(Nm)	(kN)	(N/ mm ²)	(N/ mm ²)		
CE12-16	16	32	17,0	21,0	M4 x 14	4	5	80	13	134	68	0,070	auf Anfrage on request
CE12-18	18	40	18,0	24,0	M6 x 15	4	17	180	24	119	100	0,122	
CE12-19	19	41	18,0	24,0	M6 x 15	4	17	190	24	215	100	0,126	
CE12-20	20	42	18,0	24,0	M6 x 15	4	17	200	24	204	100	0,130	
CE12-22	22	44	18,0	24,0	M6 x 15	4	17	220	24	186	90	0,138	
CE12-24	24	46	18,0	24,0	M6 x 15	6	17	360	36	170	130	0,150	
CE12-25	25	47	18,0	24,0	M6 x 15	6	17	380	36	245	130	0,160	
CE12-28	28	50	18,0	24,0	M6 x 15	6	17	420	36	219	120	0,165	
CE12-30	30	52	18,0	24,0	M6 x 15	6	17	450	36	204	120	0,174	
CE12-32	32	54	18,0	24,0	M6 x 15	6	17	480	36	191	110	0,184	
CE12-35	35	57	21,5	27,5	M6 x 15	6	17	520	36	139	90	0,242	
CE12-40	40	62	21,5	27,5	M6 x 15	8	17	600	36	122	80	0,272	
CE12-45	45	73	28,0	36,0	M8 x 22	8	41	1700	90	84	130	0,514	
CE12-50	50	78	28,0	36,0	M8 x 22	8	41	1840	90	187	120	0,570	
CE12-60	60	88	28,0	36,0	M8 x 22	8	41	2200	90	156	100	0,644	

Fertigungstechnische Änderungen vorbehalten. We reserve the right to make technical changes.

Spannelemente Clamping bushes

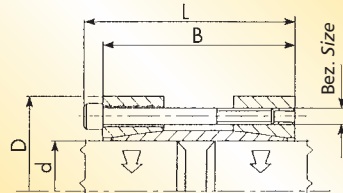

Type CE13

Bezeichnung Part No.	Abmessung Dimension				Schrauben Screws			Bei Anzugsmoment M_s übertragbar With tightening torque M_s applied		Flächen- pression Pressure		Gewicht Weight	
								Drehmoment Torque	Axialkraft Axial force	Welle Shaft	Nabe Hub		
	d	D	B	L	Bezeichnung Part No.	Anzahl No.	Anzugs- moment Tightening torque M_s	M	F	P_w	P_N		
	(mm)	(mm)	(mm)	(mm)		Stück each	(Nm)	(Nm)	(kN)	(N/ mm ²)	(N/ mm ²)		
CE13-15	15	45	50	56	M 6 x 45	4	17	150	18	81		0,378	auf Anfrage on request
CE13-16	16	45	50	56	M 6 x 45	4	17	160	18	76		0,370	
CE13-18	18	50	50	56	M 6 x 45	4	17	180	18	68		0,450	
CE13-19	19	50	50	56	M 6 x 45	4	17	190	18	64		0,444	
CE13-20	20	50	50	56	M 6 x 45	4	17	200	18	61		0,436	
CE13-24	24	55	60	66	M 6 x 55	6	17	360	27	63		0,632	
CE13-25	25	55	60	66	M 6 x 55	6	17	380	27	60		0,616	
CE13-28	28	60	60	66	M 6 x 55	6	17	370	24	46		0,752	
CE13-30	30	60	60	66	M 6 x 55	6	17	400	24	43		0,712	
CE13-35	35	75	75	83	M 8 x 70	4	41	640	32	41		1,328	
CE13-40	40	75	75	83	M 8 x 70	4	41	730	32	36		1,188	
CE13-45	45	85	85	93	M 8 x 80	6	41	1200	48	41		1,716	
CE13-50	50	90	85	93	M 8 x 80	6	41	1340	48	37		1,884	
CE13-60	60	100	85	93	M 8 x 80	8	41	2200	64	41		2,174	
CE13-70	70	115	100	110	M10 x 80	6	83	3200	80	38		4,000	

Spannelemente Clamping bushes

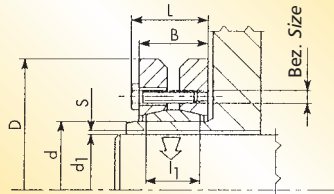

Type CE14

Bezeichnung Part No.	Abmessung Dimension							Schrauben Screws			Bei Anzugsmoment M_s übertragbar With tightening torque M_s applied		Flächen- pressung Pressure		Gewicht Weight	€/Stück each
	d	d ₁	D	B	L	I ₁	S	Bez. Size	Anzahl No.	Anzugs- moment Tighten- ing torque M_s	Drehmoment Torque	Axialkraft Axial force	Welle Shaft	Nabe Hub		
											M	F	P _W	P _N		
	(mm)	(mm)	(mm)	(mm)	(mm)	(mm)	(mm)		Stück each	(Nm)	(Nm)	(K _N)	(N/ mm ²)	(N/ mm ²)	(kg)	
CE14- 24	24	19	50	19	23,0	14	0,017	M5	6	4	180	26	140	280	0,184	
											210	27	170	280		
											250	29	200	280		
CE14- 30	30	24	60	21	25,0	16	0,017	M5	6	4	310	26	200	300	0,288	
											340	27	205	300		
											380	28	220	300		
CE14- 36	36	28	72	23	27,0	18	0,017	M6	6	12	460	50	235	360	0,468	
											590	54	240	360		
											630	58	260	360		
CE14- 44	44	32	80	25	29,0	20	0,032	M6	8	12	630	65	225	350	0,590	
											780	74	240	350		
											860	77	255	350		
CE14- 50	50	38	90	27	31,0	22	0,032	M6	8	12	940	79	180	285	0,794	
											1100	85	200	285		
											1300	90	220	285		
CE14- 55	55	42	100	30	34,0	23	0,032	M6	8	12	1200	80	155	250	1,104	
											1500	90	180	250		
											1900	100	200	250		
CE14- 62	62	48	110	30	34,0	23	0,032	M6	10	12	1800	100	190	270	1,312	
											2200	110	195	270		
											2400	120	210	270		
CE14- 68	68	50	115	30	34,0	23	0,038	M6	10	12	2000	100	140	250	1,304	
											2500	110	175	250		
											3100	120	210	250		
CE14- 75	75	55	138	33	38,0	25	0,048	M8	8	30	2500	120	190	300	1,700	
											3200	140	220	300		
											3900	150	250	300		
CE14- 80	80	60	145	32	38,0	25	0,048	M8	8	30	3200	120	185	280	2,540	
											3900	140	210	280		
											4600	160	240	280		
CE14- 90	90	65	155	39	45,0	30	0,048	M8	10	30	4700	170	180	260	3,300	
											6000	190	200	260		
											7200	210	220	260		
CE14-100	100	70	170	44	49,5	34	0,048	M8	12	30	6900	180	165	250	4,410	
											7500	220	185	250		
											9000	240	190	250		
CE14-110	110	75	185	50	57,0	39	0,048	M10	10	59	7200	230	160	260	5,900	
											9000	250	170	260		
											11000	260	185	260		
CE14-115	115	80	188	50	57,0	39	0,048	M10	10	59	8500	210	150	245	9,000	
											10000	240	170	245		
											12000	270	180	245		
CE14-125	125	85	215	54	61,0	42	0,056	M10	12	59	11000	300	160	260	8,600	
											13000	320	180	260		
											15000	350	190	260		

auf
Anfrage
on
request

Fertigungstechnische Änderungen vorbehalten. We reserve the right to make technical changes.

Spannelemente Clamping bushes

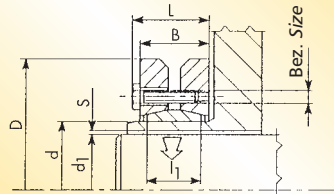

Type CE14

Bezeichnung Part No.	Abmessung Dimension							Schrauben Screws			Bei Anzugsmoment M _s übertragbar With tightening torque M _s applied		Flächen- pression Pressure		Gewicht Weight	€/Stück each
	d	d ₁	D	B	L	l ₁	S	Bez. Size	Anzahl No.	Anzugs- moment Tighten- ing torque M _s	Drehmoment Torque	Axialkraft Axial force	Welle Shaft	Nabe Hub		
											M	F	P _w	P _N		
											(Nm)	(kN)	(N/ mm ²)	(N/ mm ²)		
(mm)	(mm)	(mm)	(mm)	(mm)	(mm)	(mm)		Stück each	(Nm)	(Nm)	(kN)	(N/ mm ²)	(N/ mm ²)	(kg)		
CE14-130	130	90	215	52	59,0	42	0,056	M10	12	59	13700	300	160	250	8,700	
		95									15800	330	180	250		
		100									18200	360	190	250		
CE14-140	140	95	230	60	68,0	46	0,056	M12	10	100	15000	360	170	260	10,000	
		100									17000	400	185	260		
		105									20000	420	195	260		
CE14-155	155	105	263	62	70,0	50	0,069	M12	12	100	20000	390	180	255	11,500	
		110									23000	420	190	255		
		115									26000	450	200	255		
CE14-165	165	115	290	68	78,0	56	0,069	M16	8	250	36000	630	195	265	20,600	
		120									39000	660	200	265		
		125									44000	700	210	265		
CE14-175	175	125	300	68	78,0	56	0,079	M16	8	250	40000	650	185	250	21,400	
		130									44000	680	190	250		
		135									49000	720	200	250		
CE14-185	185	135	330	86	96,0	71	0,079	M16	10	250	55000	815	175	230	33,400	
		140									60000	875	185	230		
		145									65000	896	190	230		
CE14-195	195	140	350	86	96,0	71	0,079	M16	12	250	66000	950	210	265	38,000	
		150									76000	1000	220	265		
		155									82000	1100	230	265		
CE14-220	220	160	370	104	114,0	88	0,079	M16	15	250	95000	1200	190	235	54,000	
		165									102000	1300	195	235		
		170									110000	1300	200	235		
CE14-240	240	170	405	109	122,0	92	0,079	M20	12	490	120000	1500	210	260	67,000	
		180									140000	1600	220	260		
		190									160000	1700	225	260		
CE14-260	260	190	430	120	133,0	103	0,090	M20	14	490	165000	1700	205	250	82,000	
		200									185000	1900	220	250		
		210									205000	2000	225	250		

auf
Anfrage
on
request

Spannelemente Clamping bushes

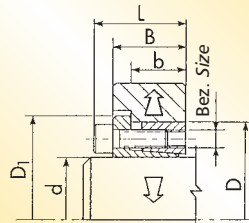

Type CE16

Bezeichnung Part No.	Abmessung Dimension						Schrauben Screws			Bei Anzugsmoment M_s übertragbar With tightening torque M_s applied		Flächen- pression Pressure		Gewicht Weight	€/Stück each
	d	D	D ₁	b	B	L	Bezeichnung Part No.	Anzahl No.	Anzugs- moment tighten- ing torque M_s	Drehmoment Torque	Axialkraft Axial force	Welle Shaft	Nabe Hub		
										M	F	P _w	P _N		
(mm)	(mm)	(mm)	(mm)	(mm)	(mm)	(mm)	Stück each	(Nm)	(Nm)	(K _N)	(N/ mm ²)	(N/ mm ²)	(kg)		
CE16-14x55	14	55	62	23	31	39	M8 x 25	4	41	287	41	311	103	0,480	
CE16-16x55	16	55	62	23	31	39	M8 x 25	4	41	329	41	272	103	0,460	
CE16-18x55	18	55	62	23	31	39	M8 x 25	4	41	370	41	242	103	0,450	
CE16-19x55	19	55	62	23	31	39	M8 x 25	4	41	390	41	229	103	0,440	
CE16-20x55	20	55	62	23	31	39	M8 x 25	4	41	410	41	218	103	0,440	
CE16-22x55	22	55	62	23	31	39	M8 x 25	4	41	451	41	198	103	0,420	
CE16-24x55	24	55	62	23	31	39	M8 x 25	4	41	492	41	182	103	0,410	
CE16-25x55	25	55	62	23	31	39	M8 x 25	4	41	513	41	174	103	0,410	
CE16-28x55	28	55	62	23	31	39	M8 x 25	4	41	575	41	156	103	0,390	
CE16-30x55	30	55	62	23	31	39	M8 x 25	4	41	616	41	145	103	0,370	
CE16-24x65	24	65	72	23	31	39	M8 x 25	5	41	616	51	227	111	0,600	
CE16-25x65	25	65	72	23	31	39	M8 x 25	5	41	641	51	218	111	0,600	
CE16-28x65	28	65	72	23	31	39	M8 x 25	5	41	718	51	194	111	0,580	
CE16-30x65	30	65	72	23	31	39	M8 x 25	5	41	770	51	182	111	0,570	
CE16-32x65	32	65	72	23	31	39	M8 x 25	5	41	821	51	170	111	0,540	
CE16-35x65	35	65	72	23	31	39	M8 x 25	5	41	898	51	156	111	0,520	
CE16-38x65	38	65	72	23	31	39	M8 x 25	5	41	975	51	143	111	0,480	
CE16-40x65	40	65	72	23	31	39	M8 x 25	5	41	1026	51	136	111	0,460	
CE16-30x80	30	80	88	26	34	42	M8 x 25	7	41	1077	72	227	108	1,040	
CE16-32x80	32	80	88	26	34	42	M8 x 25	7	41	1150	72	213	108	1,000	
CE16-35x80	35	80	88	26	34	42	M8 x 25	7	41	1257	72	194	108	0,960	
CE16-38x80	38	80	88	26	34	42	M8 x 25	7	41	1364	72	179	108	0,930	
CE16-40x80	40	80	88	26	34	42	M8 x 25	7	41	1436	72	170	108	0,900	
CE16-42x80	42	80	88	26	34	42	M8 x 25	7	41	1509	72	162	108	0,900	
CE16-45x80	45	80	88	26	34	42	M8 x 25	7	41	1616	72	151	108	0,870	
CE16-48x80	48	80	88	26	34	42	M8 x 25	7	41	1723	72	142	108	0,850	
CE16-50x80	50	80	88	26	34	42	M8 x 25	7	41	1796	72	136	108	0,820	

auf
Anfrage
on
request

Fertigungstechnische Änderungen vorbehalten. We reserve the right to make technical changes.

Klemmplatten für Zahnriemen Clamping plates for Timing Belts

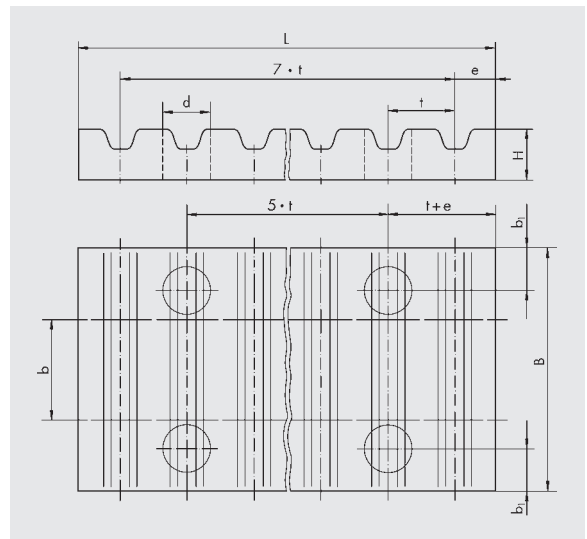

Artikel- Bezeichnung Designation	Teilung Pitch t (mm)	Riemenbreite Belt width b (mm)	Material	B (mm)	a (mm)	L (mm)	e (mm)	H (mm)	d (mm)	Gewicht Weight ≈ (kg)	€ Stück each
CP-XL 025	5,080	6,35	Al	25,5	6,0	42,5	3,5	8,0	5,5	0,020	auf Anfrage on request
CP-XL 037	5,080	9,53	Al	28,5	6,0	42,5	3,5	8,0	5,5	0,025	
CP-XL 050	5,080	12,70	Al	32,0	6,0	42,5	3,5	8,0	5,5	0,027	
CP-XL 075	5,080	19,05	Al	38,0	6,0	42,5	3,5	8,0	5,5	0,032	
CP-XL 100	5,080	25,40	Al	45,0	6,0	42,5	3,5	8,0	5,5	0,038	
CP-L 037	9,525	9,53	Al	36,0	8,0	76,6	5,0	15,0	9,0	0,095	
CP-L 050	9,525	12,70	Al	39,0	8,0	76,6	5,0	15,0	9,0	0,104	
CP-L 075	9,525	19,05	Al	45,0	8,0	76,6	5,0	15,0	9,0	0,121	
CP-L 100	9,525	25,40	Al	51,5	8,0	76,6	5,0	15,0	9,0	0,140	
CP-L 150	9,525	38,10	Al	64,0	8,0	76,6	5,0	15,0	9,0	0,177	
CP-L 200	9,525	50,80	Al	77,0	8,0	76,6	5,0	15,0	9,0	0,215	
CP-H 050	12,700	12,70	Al	45,0	10,0	106,9	9,0	22,0	11,0	0,050	
CP-H 075	12,700	19,05	Al	51,0	10,0	106,9	9,0	22,0	11,0	0,075	
CP-H 100	12,700	25,40	Al	57,5	10,0	106,9	9,0	22,0	11,0	0,100	
CP-H 150	12,700	38,10	Al	70,0	10,0	106,9	9,0	22,0	11,0	0,150	
CP-H 200	12,700	50,80	Al	83,0	10,0	106,9	9,0	22,0	11,0	0,200	
CP-H 300	12,700	76,20	Al	108,0	10,0	106,9	9,0	22,0	11,0	0,300	
CP-H 400	12,700	101,60	Al	134,0	10,0	106,9	9,0	22,0	11,0	0,400	
CP-5M 06	5,000	6,00	Al	25,0	6,0	41,8	3,2	8,0	5,5	0,015	
CP-5M 09	5,000	9,00	Al	28,0	6,0	41,8	3,2	8,0	5,5	0,018	
CP-5M 15	5,000	15,00	Al	34,0	6,0	41,8	3,2	8,0	5,5	0,022	
CP-5M 25	5,000	25,00	Al	44,0	6,0	41,8	3,2	8,0	5,5	0,030	
CP-8M 10	8,000	10,00	Al	35,0	8,0	66,0	5,0	15,0	9,0	0,075	
CP-8M 15	8,000	15,00	Al	40,0	8,0	66,0	5,0	15,0	9,0	0,085	
CP-8M 20	8,000	20,00	Al	45,0	8,0	66,0	5,0	15,0	9,0	0,100	
CP-8M 30	8,000	30,00	Al	55,0	8,0	66,0	5,0	15,0	9,0	0,120	
CP-8M 50	8,000	50,00	Al	75,0	8,0	66,0	5,0	15,0	9,0	0,170	
CP-8M 85	8,000	85,00	Al	110,0	8,0	66,0	5,0	15,0	9,0	0,250	
CP-14M 25	14,000	25,00	Al	56,0	10,0	116,0	9,0	22,0	11,0	0,315	
CP-14M 40	14,000	40,00	Al	71,0	10,0	116,0	9,0	22,0	11,0	0,405	
CP-14M 55	14,000	55,00	Al	86,0	10,0	116,0	9,0	22,0	11,0	0,495	
CP-14M 85	14,000	85,00	Al	116,0	10,0	116,0	9,0	22,0	11,0	0,860	
CP-14M 115	14,000	115,00	Al	146,0	10,0	116,0	9,0	22,0	11,0	1,195	

Klemmplatten für Polyurethan-Zahnriemen

Clamping plates for Polyurethane-Timing Belts

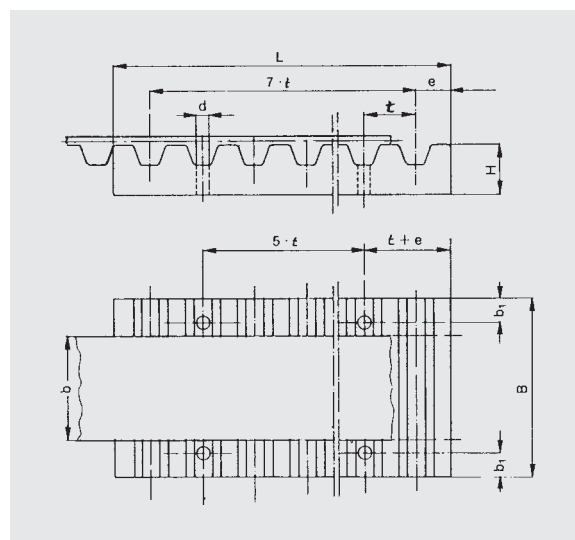

Artikel- Bezeichnung Designation	Teilung Pitch t (mm)	Riemenbreite Belt width b (mm)	Material	B (mm)	a (mm)	L (mm)	e (mm)	H (mm)	d (mm)	Gewicht Weight ≈ (kg)	€ Stück each
CP- 6 T5	5,000	6,00	Al	25,0	6,0	41,8	3,2	8,0	5,5	0,020	auf Anfrage on request
CP- 10 T5	5,000	10,00	Al	29,0	6,0	41,8	3,2	8,0	5,5	0,025	
CP- 16 T5	5,000	16,00	Al	35,0	6,0	41,8	3,2	8,0	5,5	0,030	
CP- 25 T5	5,000	25,00	Al	44,0	6,0	41,8	3,2	8,0	5,5	0,036	
CP- 32 T5	5,000	32,00	Al	51,0	6,0	41,8	3,2	8,0	5,5	0,042	
CP- 50 T5	5,000	50,00	Al	69,0	6,0	41,8	3,2	8,0	5,5	0,051	
CP- 16 T10	10,000	16,00	Al	41,0	8,0	80,0	5,0	15,0	9,0	0,115	
CP- 25 T10	10,000	25,00	Al	50,0	8,0	80,0	5,0	15,0	9,0	0,140	
CP- 32 T10	10,000	32,00	Al	57,0	8,0	80,0	5,0	15,0	9,0	0,160	
CP- 50 T10	10,000	50,00	Al	75,0	8,0	80,0	5,0	15,0	9,0	0,215	
CP- 75 T10	10,000	75,00	Al	100,0	8,0	80,0	5,0	15,0	9,0	0,290	
CP-100 T10	10,000	100,00	Al	125,0	8,0	80,0	5,0	15,0	9,0	0,370	
CP- 25 T20	20,000	25,00	Al	56,0	10,0	160,0	10,0	20,0	11,0	0,385	
CP- 32 T20	20,000	32,00	Al	65,0	10,0	160,0	10,0	20,0	11,0	0,450	
CP- 50 T20	20,000	50,00	Al	81,0	10,0	160,0	10,0	20,0	11,0	0,570	
CP- 75 T20	20,000	75,00	Al	106,0	10,0	160,0	10,0	20,0	11,0	0,755	
CP-100 T20	20,000	100,00	Al	132,0	10,0	160,0	10,0	20,0	11,0	0,940	
CP- 6 AT5	5,000	6,00	Al	25,0	6,0	41,8	3,2	8,0	5,5	0,016	
CP- 10 AT5	5,000	10,00	Al	29,0	6,0	41,8	3,2	8,0	5,5	0,019	
CP- 16 AT5	5,000	16,00	Al	35,0	6,0	41,8	3,2	8,0	5,5	0,024	
CP- 25 AT5	5,000	25,00	Al	44,0	6,0	41,8	3,2	8,0	5,5	0,031	
CP- 32 AT5	5,000	32,00	Al	51,0	6,0	41,8	3,2	8,0	5,5	0,036	
CP- 50 AT5	5,000	50,00	Al	61,0	6,0	41,8	3,2	8,0	5,5	0,043	
CP- 16 AT10	10,000	16,00	Al	41,0	8,0	80,0	5,0	15,0	9,0	0,110	
CP- 25 AT10	10,000	25,00	Al	50,0	8,0	80,0	5,0	15,0	9,0	0,135	
CP- 32 AT10	10,000	32,00	Al	57,0	8,0	80,0	5,0	15,0	9,0	0,155	
CP- 50 AT10	10,000	50,00	Al	75,0	8,0	80,0	5,0	15,0	9,0	0,205	
CP- 75 AT10	10,000	75,00	Al	100,0	8,0	80,0	5,0	15,0	9,0	0,280	
CP-100 AT10	10,000	100,00	Al	125,0	8,0	80,0	5,0	15,0	9,0	0,350	
CP- 25 AT20	20,000	25,00	Al	56,0	10,0	160,0	10,0	20,0	11,0	0,385	
CP- 32 AT20	20,000	32,00	Al	65,0	10,0	160,0	10,0	20,0	11,0	0,450	
CP- 50 AT20	20,000	50,00	Al	81,0	10,0	160,0	10,0	20,0	11,0	0,570	
CP- 75 AT20	20,000	75,00	Al	106,0	10,0	160,0	10,0	20,0	11,0	0,755	
CP-100 AT20	20,000	100,00	Al	132,0	10,0	160,0	10,0	20,0	11,0	0,940	

Weitere Abmessungen auf Anfrage. Further sizes on request.

Al = Aluminium

Versandkosten zu Lasten des Empfängers.

Bezüglich der Haftung und Lieferung verweisen wir auf unsere allgemeinen Geschäftsbedingungen.

Änderungen auf Grund technischer Neuerungen sowie Irrtum vorbehalten.

Nachdruck, auch auszugsweise, verboten. Zuwiderhandlungen werden urheberrechtlich verfolgt.

Freight charges are the responsibility of the customer.

Refer to our "General Conditions of Sale" for matters concerning liability and delivery.

Alterations due to error or to technical improvements are excepted.

Reproduction, even in extracts, is strictly forbidden. Violations of copyright will be prosecuted.

Strongbelt
Antriebstechnik

Ihr Technischer Händler:
Hermann Wendler GmbH
Am Bahnhof 4A
08280 Aue
Tel.: 03771 / 56471-0
Fax: 03771 / 56471-99
E-Mail: service@hermannwendler.de
www.hermannwendler.de